

TECHNICAL MANUAL

OPERATOR'S, ORGANIZATIONAL,

DIRECT SUPPORT, AND GENERAL SUPPORT

MAINTENANCE MANUAL

INCLUDING REPAIR PARTS AND

SPECIAL TOOLS LISTS

VOLTMETER, DIGITAL AN/GSM-64B

(NSN 6625-00-022-7894)

This copy is a reprint which includes current pages from Change 1.

HEADQUARTERS, DEPARTMENT OF THE ARMY

MAY 1975

WARNING

DANGEROUS VOLTAGES EXIST IN THIS EQUIPMENT

Be careful when working on the 115V/230V ac line connections and circuits within the voltmeter, + 200V dc is used within the voltmeter for operation.

DON'T TAKE CHANCES!

TECHNICAL MANUAL }
 No. 11-6625-444-14-1 }

HEADQUARTERS
 DEPARTMENT OF THE ARMY
 WASHINGTON, DC., 1 May 1975.

**Operator's, Organizational, Direct Support,
 and General Support Maintenance Manual
 Including Repair Parts and Special Tools Lists**

VOLTMETER, DIGITAL AN/GSM-64B

(NSN 6625-00-022-7894)

INCLUDING

PLUG-IN, ELECTRONIC TEST EQUIPMENT

PL-1370/GSM-64B

(NSN 6625-00-137-8366)

Current as of February 1975.

		Paragraph	Page
CHAPTER	1. INTRODUCTION		
Section	I. General	1 - 1 - 1 - 4 . 3	1-1
	II. Description and data	1 - 5 - 1 - 8	1-1
CHAPTER	2. INSTALLATION		
Section	I. Service upon receipt of material	2-1,2,2	2-1
	II. Installation instructions	2-3,2-4	2-2
CHAPTER	3. OPERATING INSTRUCTIONS		
Section	I. Controls and instruments	3-1-3.4	3-1
	II. Operation under unusual conditions	3-5-3-12	3-5
	III. Preparation for movement	3-13-3-15	3-7
CHAPTER	4. OPERATOR'S AND ORGANIZATIONAL, MAINTENANCE		
Section	I. Tools and equipment	4-1,4-2	4-1
	II. Preventive maintenance checks and services	4-3,4-4	4-1
	III. Troubleshooting	4-5,4-6	4-2
	IV. Maintenance of voltmeter	4-7-4-10	4-3
CHAPTER	5. FUNCTIONING OF EQUIPMENT		
Section	I. Block diagram analysis	5-1-5-3	5-1
	II. Circuit description	5-4-5-13	5-4
CHAPTER	6. GENERAL SUPPORT MAINTENANCE		
Section	I. General	6-1-6-4	6-1
	II. Tools, test equipment and troubleshooting	6-5-6-8	6-15
	III. Maintenance of the voltmeter	6-9-6-14	6-23
	IV. Testing procedures	6-15-6-17	6-27
CHAPTER	7. MATERIEL USED IN CONJUNCTION WITH AN/GSM-64B		
Section	I. Introduction to PL-1370/GSM-64B	7-1-7-4	7-1
	II. Operation of PL-1370/GSM-64B	7-5-7-9	7-2
	III. Functioning of PL-1370/GSM-64B	7-10-7-12	7-3
	IV. Troubleshooting and repair of PL-1370/GSM-64B	7-13-7-18	7-6

	Paragraph	Page
APPENDIX A	REFERENCES	A-1
	B. OPERATOR'S ORGANIZATIONAL, DIRECT SUPPORT AND GENERAL SUPPORT MAINTENANCE REPAIR PARTS ANDS SPECIAL TOOLS LISTS	
SECTION I.	Introduction	B-1
	II. Basic issue items list	B-3 1
	III. Items troop installed or authorized list	B-4
	IV. Repair parts list	B-5
GROUP 0101	Digital Voltmeter AN/GSM-64B	B-5 2
	0102 Power supply assembly	B-5 3
	0103 Range supply assembly	B-7 4
	0104 Ratio input assembly	B-8 5
	0105 Logic, PCB	B-9 6
	0106 A-D converter assembly	B-10 7
	0107 Active filter assembly	B-12 8
	0108 Buffer assembly	B-13 9
	0109 Final assembly	B-14 10
	0110 Front panel assembly	B-15 11
	0111 Rear panel assembly	B-16 12
	0112 Display assembly	B-16 13
	0113 Decimal logic assembly	B-18 14
	0114 Plug-in Electronic Test Equipment PL-1370/GSM-64B	B-18.1 15
Section	V. Special tools list (Not applicable)	
	VI. National stock number and part number index	B-19
APPENDIX	C. MAINTENANCE: ALLOCATION	
Section	I. Introduction	C-1
	II. Maintenance allocation chart	C-3

INDEX

Index 1

LIST OF ILLUSTRATIONS

<i>Figure number</i>	<i>Title</i>	<i>Page</i>
1 - 1	Digital voltmeter AN/GSM-64B	1-0
1 - 2	Front panel	1-3
1 - 3	Rear panel	1-3
1 - 4	Outline drawing	1-3
2 - 1	Packaging diagram	2-2
2 - 2	Rack installation	2-3
2 - 3	Equipment connections	2-3
3 - 1	Guard connections	3-2
3 - 2 ①	Controls, connectors, and indicators (front panel)	3-4
3 - 2 ②	Controls, connectors, and indicators (rear panel)	3-4
3 - 3	Operational check equipment connections	3-5
3 - 4	Ratio overrange limits	3-7
5 - 1	Voltmeter block diagram	5-3
5 - 2	Buffer block diagram	5-4
5 - 3	Active filter block diagram	5-5
5 - 4	A/D converter block diagram	5-7
5 - 5 ①	Timing and synchrony diagram (sheet 1 of 3)	5-10
5 - 5 ②	Timing and synchrony diagram (sheet 2 of 3)	5-11
5 - 5 ③	Timing and synchrony diagram (sheet 3 of 3)	5-12
5 - 6	Basic sample command oscillator	5-13
5 - 7	Decimal logic truth tables	5-17
5 - 8	Decimal logic (A18), schematic diagram	5-18
6 - 1	Assembly and troubleshooting test point location	6-4
6 - 2	Alignment adjustment and test point location	6-5
6 - 3	Buffer (A11) component parts	6-6
6 - 4	Active filter (A10) component parts	6-7
6 - 5	A-to-D converter (A9) component parts	6-8
6 - 6	Logic (A8) component parts	6-9
6 - 7	Display (A14) component parts	6-10
6 - 8	Range delay (A2) component parts	6-11
6 - 9	Power supply (A1) component parts	6-12

<i>Figure number</i>	<i>Title</i>	<i>Page</i>
6-10	Ratio input (A3) component parts	6-13
6-11	Decimal logic (A18) component parts	6-14
6-12	Front panel (A16) component parts	6-14
6-13	Rear panel (A17) component parts	6-15
6-14	A-to-D converter and logic, troubleshooting	6-17
6-15	Display troubleshooting	6-18
6-16	A-to-D converter waveforms	6-19
6-17	Analog storage waveforms	6-19
6-18	16-State binary counter waveforms	6-19
6-19	6-State shift register waveforms	6-20
6-20	A9TP2 zero input	6-20
6-21	A9TP2 6.3524V input	6-21
6-22	A9TP2 0.99999V input	6-21
6-23	Disassembly sequence (a through m)	6-24
6-24	Disassembly sequence (n through u)	6-25
6-25	Ratio check equipment connections	6-28
6-26	Alignment equipment connections	6-29
7-1	Ac converter, location diagram	7-2
7-2	Ac converter, block diagram	7-4
7-3	Plug-in, Electronic Test Equipment PL- 1370 /GSM-64B	7-7
6-26	Alignment equipment connections	6-29
1	Extender card	B-27
2	Digital voltmeter AN/GSM-64B	B-28
3	Power assembly	B-29
4	Range delay assembly	B-30
5	Ratio input assembly	B-31
6	Logic assembly	B-32
7	A-to-D converter assembly	B-33
8	Active filter assembly	B-34
9	Buffer amplifier assembly	B-35
10	Chassis assembly	B-36
11	Front panel assembly	B-37
12	Rear panel assembly	B-38
13	Display assembly	B-39
14	Decimal logic assembly	B-40
FO-1	Color code marking for MIL STD resistors, inductors, and capacitors	Fold-in
FO-2	Buffer (A11) schematic diagram	Fold-in
FO-3	Active filter (A10) schematic diagram	Fold-in
FO-4	A-to-D converter (A9) schematic diagram	Fold-in
FO-5	Logic (A8) schematic diagram	Fold-in
FO-6	Display (A14) schematic diagram (sheet 1 of 2)	Fold-in
FO-6	Display (A14) schematic diagram (sheet 2 of 2)	Fold-in
FO-7	Range delay (A2) schematic diagram	Fold-in
FO-8	Power supply (A 1) schematic diagram	Fold-in
FO-9	Ratio input (A3) schematic diagram	Fold-in
FO-10	Interconnect diagram	Fold-in
FO-11	Wiring diagram	Fold-in
FO-12	AC converter, schematic diagram	Fold-in

LIST OF TABLES

<i>Number</i>	<i>Title</i>	<i>Page</i>
3-1	Controls and indicators	3-2
3-2	DC ratio measurements	3-6
3-3	Data drive signals	3-6
4-1	Materials required	4-1
4-2	Operator's preventive maintenance checks and services	4-2
4-3	Organizational preventive maintenance checks and services	4-2
5-1	Sample and hold switching	5-8
5-2	Shift register outputs	5-9
5-3	Sixteen-state binary output	5-9
6-1	Power supply (A1) voltage measurements	6-1
6-2	Range delay (A2) voltage measurements	6-1

Number	Title	Page
6-3	Ratio input (A3) voltage measurements	6-2
6-4	Logic (A8) voltage measurements	6-2
6-5	Active filter (A10) voltage measurements	6-3
6-6	Buffer (A11) voltage measurements	6-3
6-7	Required test equipment	6-15
6-8	Power supply (A1) checks	6-16
6-9	Digital section subsections	6-16
6-10	Buffer (A11) resistor values	6-27
6-11	Voltmeter accuracy checks	6-28
6-12	Ladder alignment	6-30
6-13	Comparator level adjustment	6-30
6-14	Buffer DC alignment	6-31
7-1	Performance checks	7-6
7-2	Voltage measurements	7-8
7-3	Ac converter function command check	7-8
7-4	Ac converter relay truth table	7-8

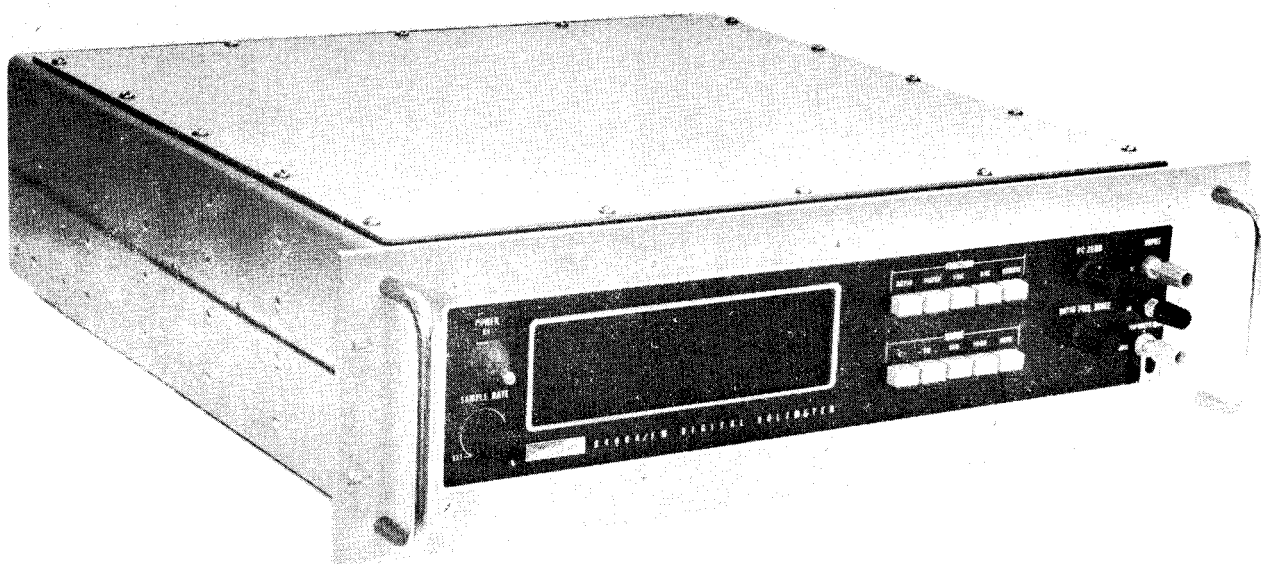

EL6625-444-14-TM-1

Figure 1-1. Digital Voltmeter AN/GSM-64B.

CHAPTER 1

INTRODUCTION

Section I. GENERAL

1-1. Scope

This manual describes Voltmeter, Digital AN/GSM-64B (voltmeter) (fig. 1-1) and provides instructions for operation and organizational and general support maintenance. Direct support maintenance is not authorized for the AN/GSM-64B. Instructions are provided for the operator and the organizational repairman for installation, operation, preventive maintenance, and replacement of parts available at organizational maintenance. Circuit functioning is included for general support maintenance, together with instructions appropriate to this category of maintenance for troubleshooting, testing, adjusting, aligning and repairing the equipment and replacement of maintenance parts. Chapter 7 describes optional plug-in subassemblies which will extend the functional capability of the voltmeter. The options are not general issue, but are available to those maintenance facilities authorized their use.

1-2. Indexes of Publications

a. DA Pamphlet 310-4. Refer to the latest issue of DA Pam 310-4 to determine whether there are new editions, changes, or additional publications pertaining to the equipment.

b. DA Pamphlet 310-7. Refer to DA Pam 310-7 to determine whether there are modification work orders (MWO's) pertaining to the equipment.

1-3. Forms and Records

a. Reports of Maintenance and Unsatisfactory Equipment. Maintenance forms, records, and reports which are to be used by maintenance personnel at all maintenance levels are listed in and prescribed by TM 38-750.

b. Report of Packaging and Handling Deficiencies. Fill out and forward DD Form 6 (packaging Improvement Report) as prescribed in

AR 700-58/NAV SUPINST 4030.29/AFR 71-13/MCO P4030.29A, and DSAR 4145.8.

c. Discrepancy in Shipment Report (DISREP) (SF 361). Fill out and forward Discrepancy in Shipment Report (DISREP) (SF 361) as prescribed in AR 55-38/NAV SUPINST 4610.36A/AFR 75-18/MCO P4610.19B, and DSAR 4500.15.

1-4. Recommendation for Maintenance Publication Improvements

Report of errors, omissions, and recommendations for improving this publication by the individual user is encouraged. Reports should be submitted on DA Form 2028 (Recommended Changes to Publications and Blank Forms) and forwarded direct to Commander, US Army Electronics Command, ATTN: DRSEL-MA-Q, Fort Monmouth, NJ 07703.

1-4.1. Administrative Storage

For procedures, forms, and records, and inspections required during administrative storage of the equipment, refer to TM 740-90-1.

1-4.2. Destruction of Army Materiel

Demolition and destruction of electronic equipment will be under the direction of the Commander and in accordance with TM 750-244-2.

1-4.3. Reporting Equipment Improvement Recommendations (EIR).

EIR will be prepared using DA Form 2407, Maintenance Request. Instructions for preparing EIR's are provided in TM 38-750, The Army Maintenance Management System. EIR's should be mailed directly to Commander, US Army Electronics Command, ATTN: DRSEL-MA-Q, Fort Monmouth, New Jersey 07703. A reply will be furnished directly to you.

Section II. DESCRIPTION AND DATA

1-5. Purpose and use

a. The voltmeter is a precision digital instrument capable of accurately measuring voltages

from 0 to 1,100 vdc. It also allows voltage ratio comparison between the voltage input and an external reference voltage from ± 1.0 to 100 vdc.

Five full decades of digits plus a sixth digit overrange indicator display the measured input or percentage ratio to the external reference voltage. Polarity of the input is displayed adjacent to the overrange digit. Pushbutton switches allow selection of modes of operation and ranges. A lighted function annunciator continuously indicates which mode of operation is selected.

b. Special features include a variable sample rate, selectable four-pole filter, auto ranging, and data output. Provisions have also been made to allow installation of optional plug-in assemblies to expand measurement and system capability. Options which may be installed are as follows:

- (1) Ac converter (-01).
- (2) Data output (-03).
- (3) Remote control (-04).

1-6. Description

a. The voltmeter is completely solid-state in design and most circuitry is located on easily removed plug-in cards. An extender card located inside the voltmeter allows servicing of each plug-in card. All circuitry is housed within a metal inclosure fitted with protective covers. The covers are easily removed to provide maintenance access.

b. The chassis is a full rack width in size and designed for installation in a standard 19-inch equipment rack. Holes in the front panel facilitate rack mounting. Nonmarring feet are also included to allow bench-top use.

c. All operating controls, indicators, and input connectors are located on the front panel (fig. 1-2). The power fuse and connector, 1 15/230V AC slide switch, data output. connector, rear input connectors, and external reference input connectors are located on the rear panel (fig. 1-3).

1-7. Technical Characteristics

a. Mainframe Specifications

Dc volts:	
Ranges	±1V, ±10V, ±100V, ±1000V
Polarity	Automatic, instantaneous selection and display
Resolution	±0.001% of range
Overrange	20% , ±1100V maximum input on 1000V range

Overload	±1100V DC or RMS (1500V peak) may be applied to any range without damage
Accuracy	±0.01% of reading or ±1 digit Periodic use of DC ZERO typically once every 8 to 24 hours, is required to maintain accuracy.
Temperature coefficient	±0.0007% of reading per °C.
Input impedance:	
±10V range	10,000 megohms
±100V, ±1000V range	10 megohms
Noiserejection:	
Normal mode (filtered)	60dB@ 60Hz
Common mode (with up to 1K unbalance in either input lead):	
DC	140 dB
Ac	120dB@ 60Hz
Balancing time	2 seconds
Auto range	Automatically selected

Dc ratio:	
Accuracy	0.005%, of reading or ±1 digit
Input impedance	Greater than 50 kilohms at external dc voltage ratio input.

Ranges:

	Input voltage ranges		
EXTV			
REF	10v	100V	1000V
1V	100%@ 1V in	1000%@ 10V in	10,000%@ 100V in
10V	100%@ 10V in	1000%@ 100V in	10,000%@ 1000 V in
100V	10%@ 10V in	100%@ 100V in	1,000%@ 1000V in

b. General Specifications.

Temperature:	
operating	+32 °F. to +122°F
Nonoperating	-65° F. to +160°F.
Humidity	Meets requirements of MIL-STD-810, Procedure II, Method 507.
Altitude	Meets requirements of MIL-STD-810, Procedure 1, Method 500
Vibration	Meets requirements of MIL-STD-810, Part 1, Procedure IX, Method 514
Input power	115/230V AC + 10%, 50 to 400 Hz, single phase
Warmup time	30 minutes
Dimensions	See figure 1-4

1-8. Items Comprising an Operable Equipment

Digital Voltmeter AN/GSM-64B and power cable comprise an operable equipment.

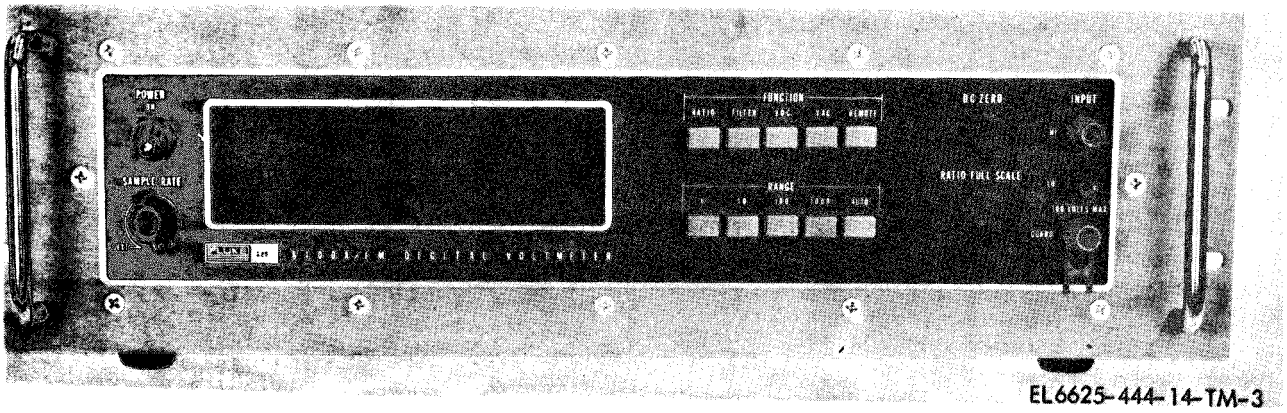

Figure 1-2. Front panel.

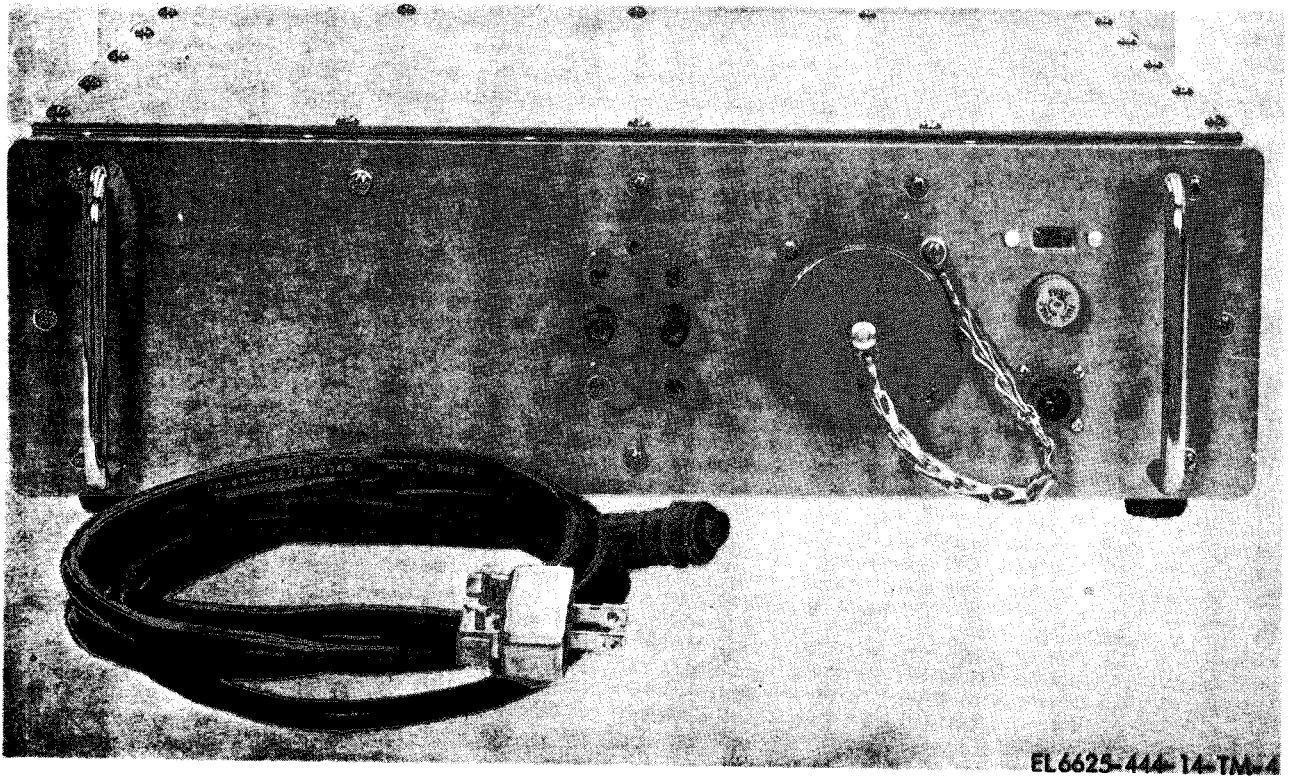

Figure 1-3. Rear panel.

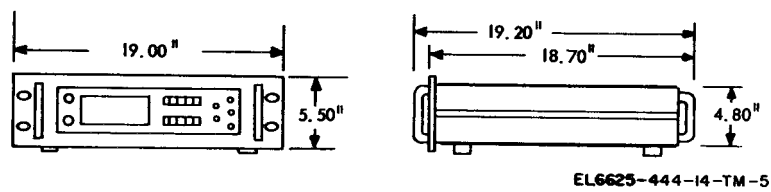

Figure 1-4. Outline drawing.

CHAPTER 2

OPERATING INSTRUCTIONS

Section 1. SERVICE UPON RECEIPT OF MATERIAL

2-1. Unpacking

a. Packaging. When packaged for shipment, the voltmeter is placed in a carton and packed in a wooden box. A typical packaging diagram and its contents are shown in figure 2-1.

b. Removing Contents.

- (1) Cut and fold back metal straps.
- (2) Remove nails from top of box and lift off top.
- (3) Remove envelopes that contain manuals and test leads.
- (4) Remove packing around outer carton wrapped in waterproof bag.
- (5) Remove outer carton from box and open moisture-vaporproof barrier and outer carton.
- (6) Open the inner moisture-vaporproof barrier and carton.
- (7) Remove voltmeter from inner carton.

2-2. Checking Unpacked Equipment

a. Inspect the equipment for damage incurred during shipment. If the equipment has been damaged, report the damage on DD Form 6 (para 1-3).

b. Check the equipment against the packing slip to see if the shipment is complete. Report all discrepancies in accordance with TM 38-750. The equipment should be placed in service even though a minor assembly or part that does not affect proper functioning is missing.

c. Check to see whether the equipment has been modified. (Equipment which has been modified will have the MWO number on the front panel, near the nomenclature plate.) Check also to see whether all current applicable MWO's have been applied. (Current MWO'S applicable to the equipment are listed in DA Pam 310-7.)

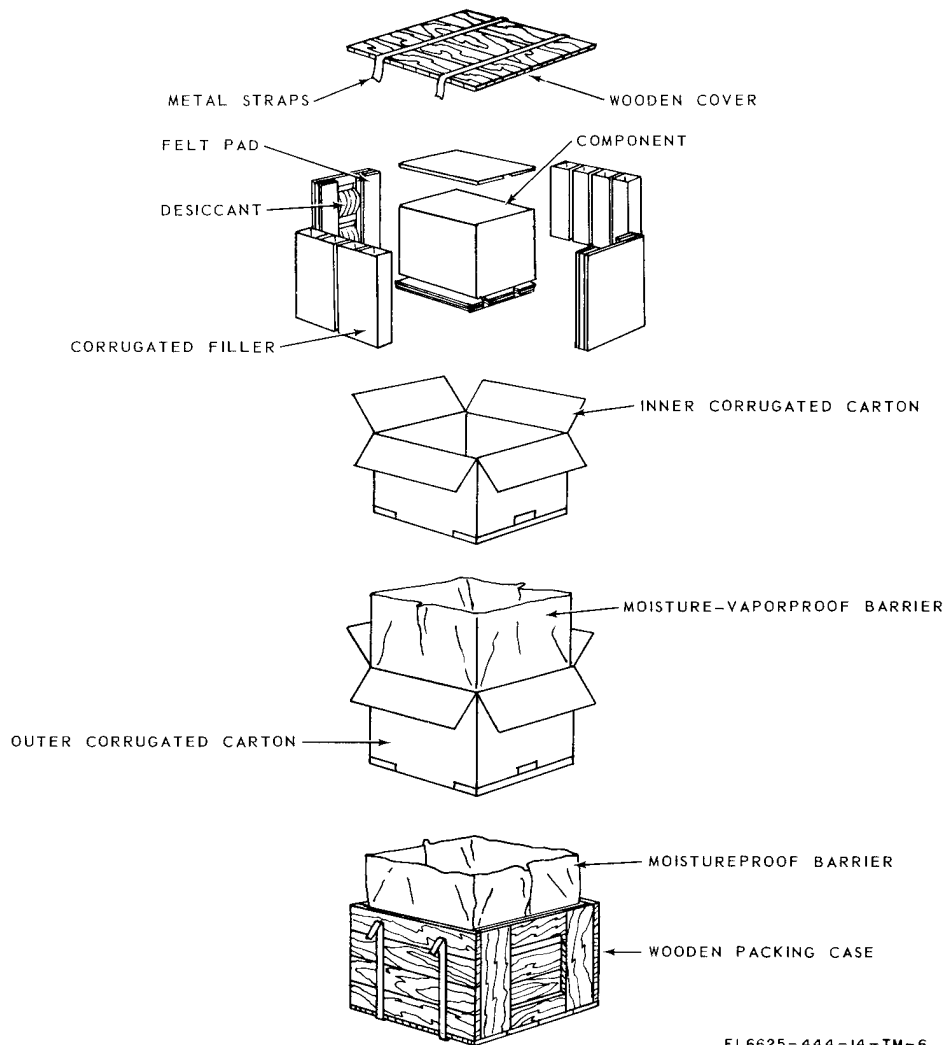

Figure 2-1. Packaging diagram

Section II. INSTALLATION INSTRUCTIONS

2-3. Rack Installation

a. *General.* The voltmeter is designed for installation in a standard 19-inch wide equipment rack. Attachment to the equipment rack is facilitated directly through holes in the front panel of the voltmeter.

b. *Procedure.*

(1) Position the voltmeter in the equipment rack and attach in place in accordance with figure 2-2.

(2) Set the slide switch (16, fig. 3-2②) on

the rear panel to 115 (if line power is 115V AC) or 230 (if line power is 230V AC).

(3) Connect line power cord to input power connector on rear panel and then plug it into the nearest line power receptacle.

CAUTION

Insure that the round pin on the line power cord is always connected to a high quality earth ground.

(4) Make the appropriate connections at the rear panel as shown in figure 2-3. The voltage

input can be applied to input terminals on the front or rear panel, as desired.

NOTE

Outputs from the data output connector,

J40, must be isolated and guarded. Failure to do so will impair equipment operation.

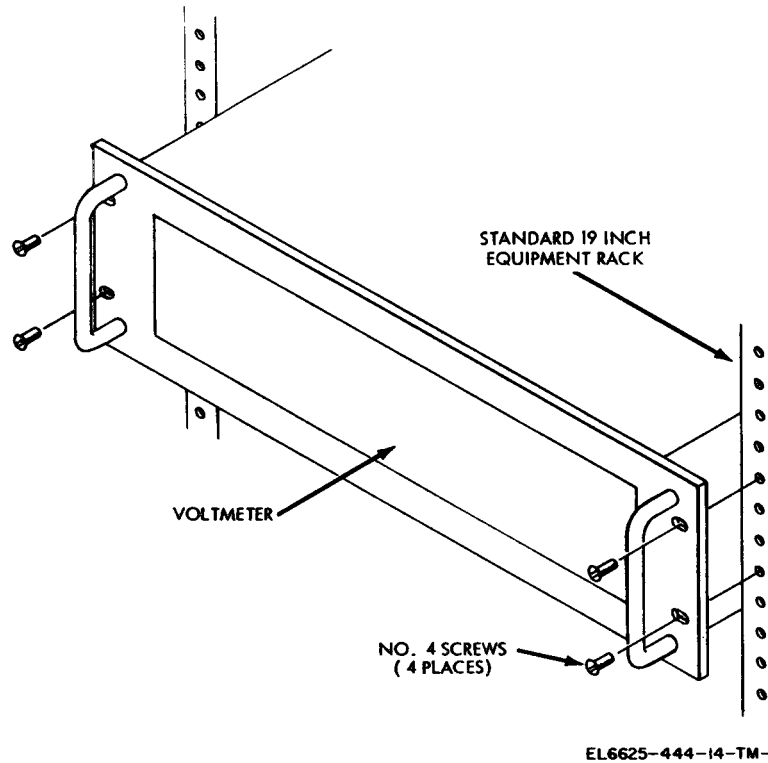

Figure 2-2. Rack installation.

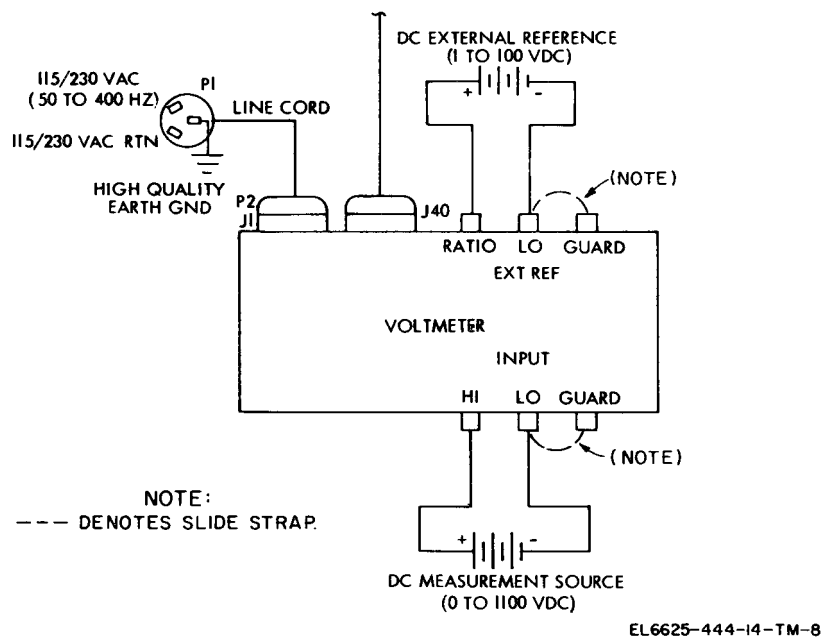

Figure 2-3. Equipment connections.

2-4. Bench-Top Use

a. The voltmeter can be operated on either a bench or shelf, as desired. Nonmarring feet on the bottom of the voltmeter facilitate bench or shelf use.

b. Preparation of the voltmeter for bench or shelf operation is the same as rack installation (para 2-3 *b*) with the exception of step (1).

CHAPTER 3

OPERATING INSTRUCTIONS

Section 1. CONTROLS AND INSTRUMENTS

3-1. General

This section describes overload protection and guarded measurement features of the voltmeter. It also contains an illustration which locates and describes each control, connector and indicator.

3-2. Damage From Improper Settings

The voltmeter is fully protected from overloads applied to the input terminals in all ranges and modes of operation. In the VDC and RATIO functions, $\pm 1100\text{V}$ DC or RMS (1500V peak to peak) can be applied to the input without damaging the volt meter. Potentials of up ± 150 vdc can also be applied to the external reference input terminals without damaging the voltmeter.

3-3. Guarded Measurements

a. A system of internal shields and guards have been included in the design and construction of the voltmeter. These shields and guards can be connected as shown in figure 3-1 to minimize common mode-to-normal mode signal conversion and induction of noise. The resulting measurement process in the voltmeter is sub-

sequently capable of a fully floating measurement without degradation of accuracy.

b. Guarded measurements will be necessary under the following conditions:

(1) Long signal leads together with a high source impedance.

(2) During floating measurements when common mode voltage is at a high potential, high frequency, or both conditions exist.

(3) During operation of the voltmeter in the presence of high level, radiated noise, an example of which is stray fields at the powerline frequency.

c. Under normal operating conditions (absence of common mode signals), the GUARD terminal in the input terminal group shall be connected to the LO terminal. A slide strap is provided at the GUARD terminal for convenience in connection.

NOTE

INPUT terminals on the front panel and rear panel are connected in parallel. Always check both terminal groups to insure desired connections are made.

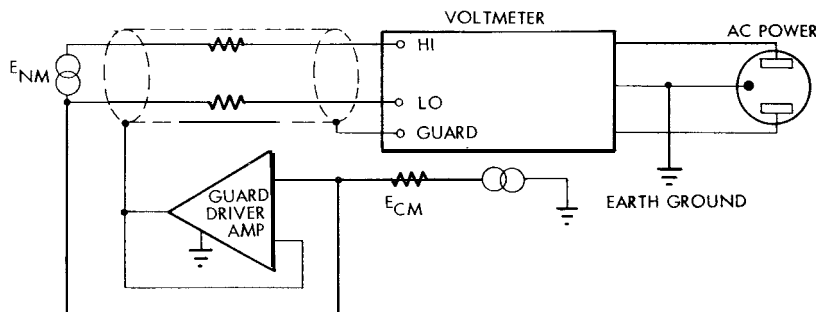
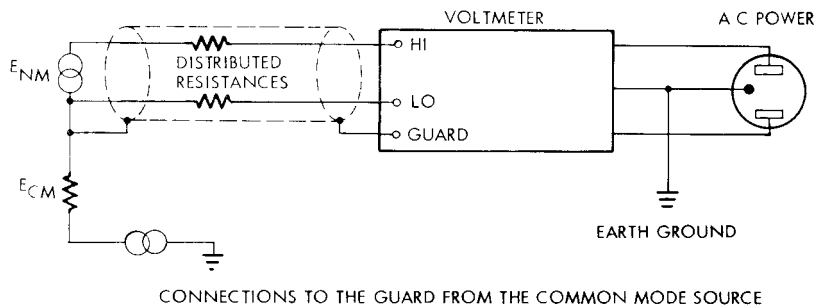

EL6625-444-14-TM-9

Figure 3-1. Guard connections.

3-4. Operator Controls

The location of controls, connectors, and in-

dicators is shown in figure 3-2, their described in table 3-1.

Table 3-1. Controls and Indicators

Ref. No.	Control, indicator, or connector	Function										
1	POWER switch	Controls application of input power.										
2	Polarity indicator	Automatic indication of input polarity for dc voltage "+" for positive input voltages and "-" for negative input voltages.										
3	Readout tubes	Display digital readout from left to right, with overrange digit displayed in left-most tube. All tubes display a decimal point, depending on range. Full overrange readout on each range would appear as follows: <table style="margin-left: 40px; border: none;"> <thead> <tr> <th>Range</th> <th>Readout</th> </tr> </thead> <tbody> <tr> <td>1</td> <td>1.19999</td> </tr> <tr> <td>10</td> <td>11.9999</td> </tr> <tr> <td>100</td> <td>119.999</td> </tr> <tr> <td>1000</td> <td>1199.99</td> </tr> </tbody> </table>	Range	Readout	1	1.19999	10	11.9999	100	119.999	1000	1199.99
Range	Readout											
1	1.19999											
10	11.9999											
100	119.999											
1000	1199.99											
4	Function/status annunciator	Indicate instrument function and status as follows: <table style="margin-left: 40px; border: none;"> <tbody> <tr> <td>A C</td> <td>Operating in ac voltage mode.</td> </tr> <tr> <td>DC</td> <td>Operating in dc voltage mode.</td> </tr> <tr> <td>%R</td> <td>Operation in ratio mode.</td> </tr> <tr> <td>FILT</td> <td>Active 4-pole filter called for maximum noise rejection.</td> </tr> <tr> <td>OVER</td> <td>Input is over the 20% overrange capability.</td> </tr> </tbody> </table>	A C	Operating in ac voltage mode.	DC	Operating in dc voltage mode.	%R	Operation in ratio mode.	FILT	Active 4-pole filter called for maximum noise rejection.	OVER	Input is over the 20% overrange capability.
A C	Operating in ac voltage mode.											
DC	Operating in dc voltage mode.											
%R	Operation in ratio mode.											
FILT	Active 4-pole filter called for maximum noise rejection.											
OVER	Input is over the 20% overrange capability.											

Table 3-1. Controls and Indicators—Continued

Ref. No.	Control, indicator, or connector	Function
5	FUNCTION switches	Select the desired operating mode: RATIO..... Places voltmeter in ratio mode with full-scale ranges of 10, 100, and 1,000. FILT..... Controls 4-pole active input filter to provide desired noise rejection. Functional for dc voltage, ac voltage, and resistance measurements. VDC..... Places voltmeter in dc voltage mode with full-scale ranges of 10, 100, and 1,000. VAC..... Places voltmeter in ac voltage mode with full-scale ranges of 10, 100, and 1,000. REMOTE..... Places voltmeter in remote mode, enabling function and range to decontrolled remotely via the remote control unit.
6	DC ZERO control	Adjust for .00000±1 with VDC, filter and 10 range called and INPUT terminals shorted.
7	INPUT terminals	HI, LO input connections for dc and ac voltage measurements.
8	GUARD terminals	Connects to internal guard chassis. When properly connected externally, provides maximum common mode rejection.
10	RATIO FULL SCALE control	Adjusted for minimum readout with VDC, FILT, RATIO, and 10 buttons depressed and equal voltage applied to EXT REF and INPUT terminals.
10	AUTO RANGE switch	Places voltmeter in autorange mode, providing automatic ranging for each function and its range complement.
11	Manual RANGE	Enable manual selection of range. Not calling a range or incorrect range selection automatically places voltmeter in autorange mode.
12	SAMPLE RATE control	Permits variation of sample rate from 2 readings per second to 1 reading per 4.5 seconds. In Exposition (fully counterclockwise), sample rate control is transferred to remote control point via the data output unit. If the data output option is not installed and the control is turned to EXT, the voltmeter will readout and display from its internal storage circuitry indefinitely, with readout corresponding to value of last measurement sample.
13	Rear INPUT terminals	Provides connections for rear input.
14	EXTERNAL REFERENCE ratio terminals	Provides connections for ± external reference voltage input for dc voltage ratio measurements.
15	Data output connector	Provides access to data drive signals.
16	115/230 volt input power switch	Selects either 115 or 230 volt ac line operation.
17	Line FUSE	Protects voltmeter from overloads. Fuse rating is AGC ½ ampere.
18	AC line voltage connector	Mates with polarized 3-wire power cord for connection to 115/230 volt, 50 Hz to 400 Hz, single phase, ac line.
19	Guard terminals	Connects to each other and to internal guard chassis. When properly connected externally, provides maximum common mode rejection.

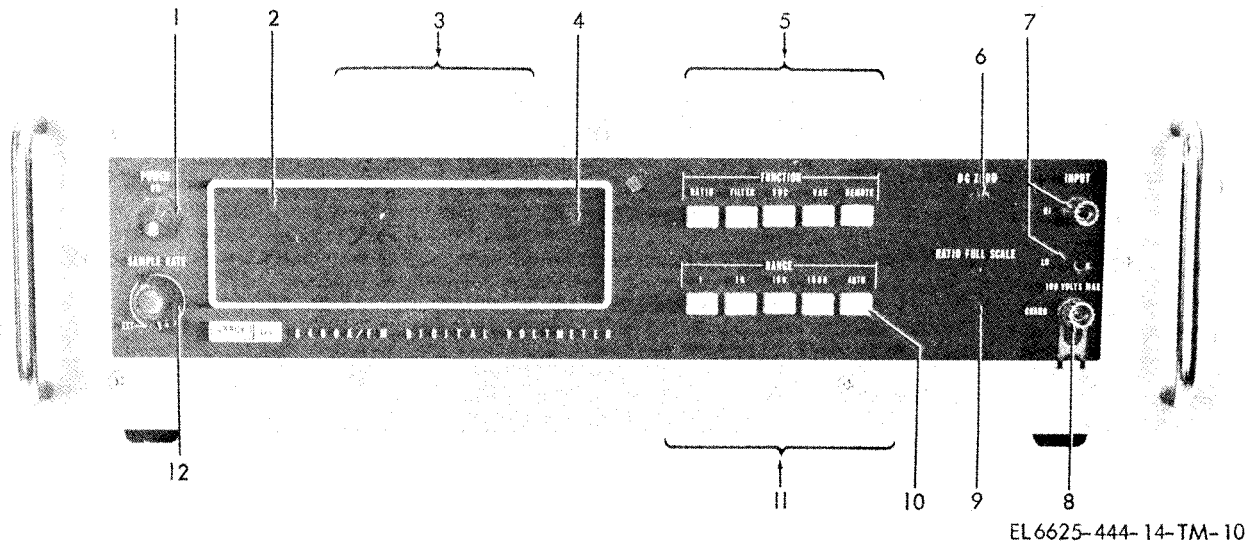

EL 6625-444-14-TM-10

Figure 3-2 ①. Controls, connectors, and indicators (front panel).

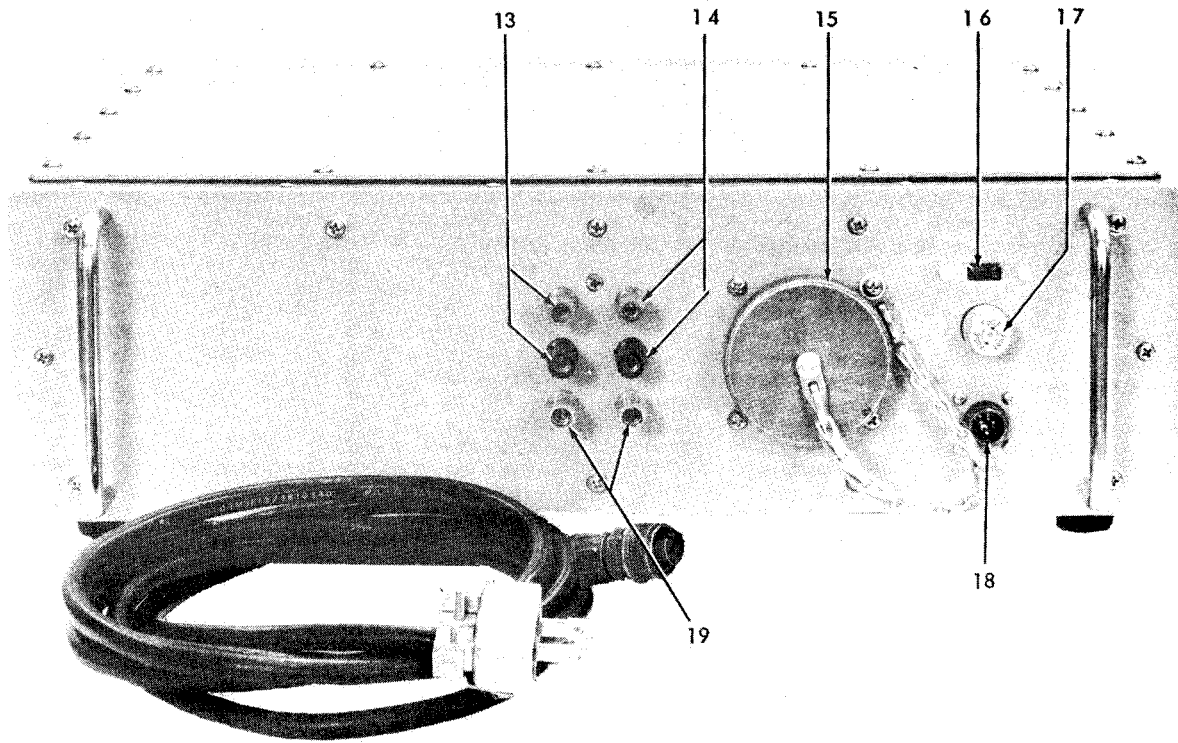

EL-6625-444-14-TM-11

Figure 3-2 ②. Controls, connectors, and indicators (rear panel).

Section II. OPERATION UNDER USUAL CONDITIONS

3-5. General

This section contains operating procedures for the voltmeter. It may be used as a voltmeter or ratiometer to measure or compare voltages from 0 to 1100V DC. A printer output capability is also described.

3-6. Preliminary Starting Procedure

a. Disconnect test leads from INPUT terminals.

b. Set voltmeter controls as follows:

POWER ON
SAMPLE RATE Fully clockwise

c. Select VDC and 10V range.

d. Connect a shorting jumper between the HI and LO INPUT terminals. Verify that GUARD terminal is connected to LO INPUT terminal.

e. Rotate DC ZERO control to obtain a readout of 00.0000.

f. Disconnect shorting jumper from INPUT terminals and reconnect test leads (red lead to HI and black lead to LO).

3-7. Initial Adjustments

The following checks can be performed to verify correct operation of the voltmeter:

a. Make the equipment connections shown in figure 3-3.

b. Set the dc voltage source output to zero.

c. Verify that the voltmeter readout is 00.0000.

d. Set the dc voltage source output to $\pm 10.0V$ DC.

e. Verify that the voltmeter readout is $+10.0000 \pm 0.002$.

f. Select RATIO mode on the voltmeter.

g. Rotate RATIO FULL SCALE control on the voltmeter to obtain a readout of +100.000.

h. Set the dc voltage source output to - 10.0V DC by reversing the LO and HI INPUT leads.

i. Verify that the voltmeter readout is +100.000 or that it can be set to this value using the RATIO FULL SCALE control.

j. Set the dc source output to zero and disconnect input leads.

k. Connect a shorting jumper between the LO and HI INPUT terminals.

l. Verify that the voltmeter readout is 000.000.

m. Disconnect shorting jumper and dc voltage source.

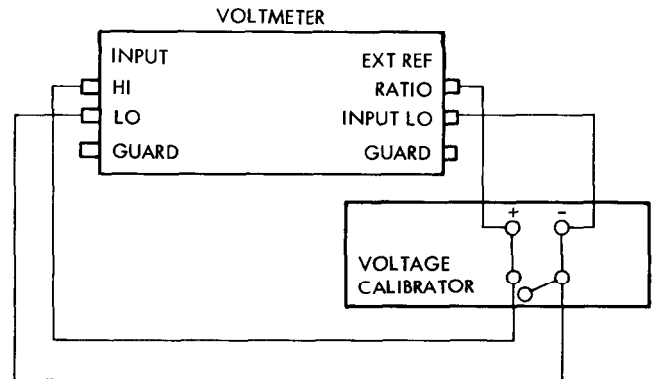

EL6625-444-14-TM-14

Figure 3-3. Operational check equipment connections

3-8. Dc Voltage Measurement

The voltmeter is capable of measuring voltages from 0 to 1100V DC in four separate ranges (1, 10, 100, or 1000 volts). Automatic ranging can be selected, as desired. Polarity of the voltage is automatically indicated. If desired, an active filter can be selected to improve noise rejection. Operation is as follows:

a. Perform the preliminary starting procedure in paragraph 3-6.

NOTE

Guarded measurements (para 3-3) should be considered if the source to be measured is suspected of containing induced noise or common mode voltages.

b. Depress VDC FUNCTION switch and AUTO RANGE switch.

c. Connect test leads to dc voltage source (red to positive side and black to negative).

d. Rotate SAMPLE RATE control for desired sampling rate (two readings a second to one reading every 4.5 seconds). DO NOT rotate control fully counterclockwise or the readout will continuously indicate the first sampling of the input, regardless of any later change.

e. Observe the readout to obtain magnitude and polarity of measured voltage. If readout fluctuates, depress FILT FUNCTION switch to improve noise rejection.

f. If desired, select progressively lower ranges (i.e., 1000, 10;10, or 1) to maximize resolution in digital readout.

3-9. Dc Ratio Measurement

The RATIO mode of operation allows comparison of a measured input voltage to a fixed, external reference voltage. In this mode of operation, the readout is expressed in percent (%) of difference between the measured input and the external reference voltage. For example, if both inputs are

equal, the readout is +100 percent. If the input is 10 times greater than the reference, or vice versa, the readout will be ± 1000 percent. Ratio mode reference voltages, inputs, and the readouts are given in table 3-2. Overrange limits are shown in figure 3-4. To operate the voltmeter in the ratio mode, proceed as follows:

Table 3-2. Dc Ratio Measurements

Ext ref ('REF') (VDC)	Input voltage (VDC)	Selected range	Readout (%)
± 1.0 to 10 V	0 to 1.2VxV REF	1 00 to ± 119.999
	0 to 12VxV REF	1 0 00 to ± 1199.99
	0 to 120VxV REF	1 0 0 0	0 to ± 11999.9
±10 to ± 100V	0 to 120VxV REF	AUTO.	0 to ± 11999.9
	0 to 0.12 VXVREF	10	0 to 311.9999
	0 to ± 1.2 VxV REF	1 0 00 to ± 119.999
	0 to ± 12VxV REF	1 0 0 0	0 to ± 1199.99
	0 to ± 12 VxV REF	A U T O	0 to ± 1199.99

Table 3-3. Data Drive Signals

J40 pin #	Logic or function
A	SIG NO1
BCCO
C	P O L M E M
D	F I L T
EEXT TRIG
F	FUNCTION REMOTE BUSS
G cmv
H	C
J	VAC INTERLOCK
K	K
L	bmV
M F
N	a
O	B
P	+ 5V
Q	
R	INT REF DISABLE
S E
TA
U	M
V LOGIC COMMON
W	ZERO
X VAC DN ENABLE
YD
Z	GUARD

- a. Measure the input voltage in accordance with paragraph 3-8.
- b. Apply the external reference voltage to the EXT REF terminals on the rear panel.
- c. Depress the RATIO FUNCTION switch.

- d. Observe the readout to obtain the percentage difference (ratio) between the measured input and the external reference. The polarity sign indicates whether the measured input is above (+) or below (-) the external reference.

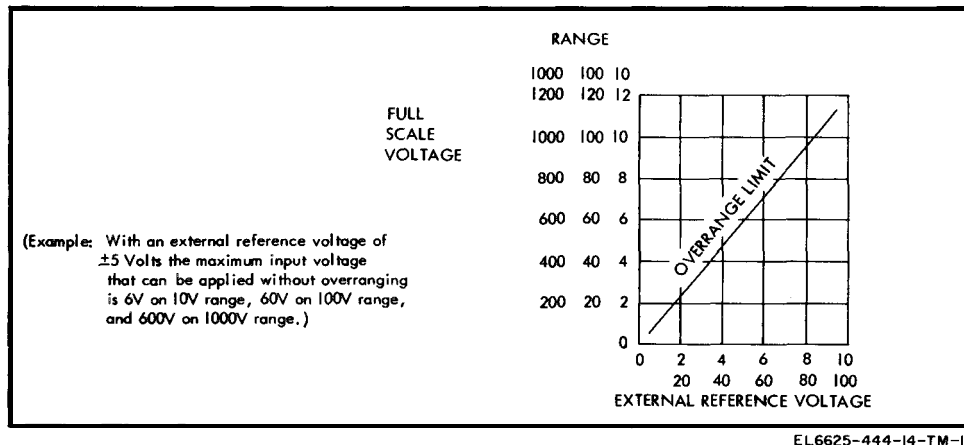

Figure 3-4. Ratio overrange limits.

3-10. Printer Output Use

Data outputs representing logic status conditions within the voltmeter are made available at J40 on the rear panel of the voltmeter. Pin numbers and signal functions at J40 are described in table 3-3. Monitoring of the signals is possible with a printer, provided each signal line is isolated and guarded; otherwise, operation of the voltmeter will be impaired due to loading effects of the printer. Required mating connector J40 is an MS3106R-36-10P. This connector is not supplied with the voltmeter.

3-11. Standby Operation.

The voltmeter is completely solid-state in design and construction. Consequently, no warmup period or continuous operation is necessary. When measurements are not being made, the voltmeter may be left on or off, as desired.

3-12. Procedures for Shutdown

Turn off of the voltmeter can be done at any time with inputs applied or disconnected. To turn off the voltmeter, set the POWER switch on the front panel to OFF.

Section III. PREPARATION FOR MOVEMENT

3-13. General

This section contains information regarding movement of the voltmeter. Rack removal is described first, followed by instructions for bench or shelf movement.

3-14. Rack Removal

- Set the POWER switch to OFF.
- Disconnect test leads and cables from the front and rear panel, as applicable.

- Remove the voltmeter from the equipment rack by removing the mounting screws from the front panel (fig. 2-2).

3-15. Bench/ Shelf Movement

- Set the POWER switch to OFF.
- Disconnect test leads and cables from the voltmeter.
- Grasp the voltmeter by the handles on the front panel and carry it to the desired location.

CHAPTER 4

OPERATOR AND ORGANIZATIONAL MAINTENANCE

Section I. TOOLS AND EQUIPMENT

4-1. General

This section contains a list of supplies required for operator and organizational maintenance. Repair parts, special tools, special test equipment, and accessories prescribed for use with the voltmeter are listed in appendix B.

4-2. Materials Required

The items listed in table 4-1 are required for operator and organizational maintenance.

Table 4-1. Materials Required

<i>Qty</i>	<i>Nomenclature</i>	<i>Available from</i>
1 qt	Alcohol, anhydrous	MIL-C-10428

Section II. PREVENTIVE MAINTENANCE CHECKS AND SERVICES

4-3. General

a. This section describes preventive maintenance checks and services which may be performed by operator, organizational, and direct support maintenance activities.

NOTE

The voltmeter does not require lubrication and none is recommended.

b. To insure that the voltmeter is always ready for operation, it must be inspected systematically so that defects may be discovered and corrected before they result in serious damage or failure. The necessary preventive maintenance checks and services to be performed are listed and described in tables 4-2 and 4-3. The item numbers indicate the sequence of and minimum inspection required. Defects discovered during operation of the voltmeter will be noted for future correction to be made as soon as operation is ceased. Stop

operation immediately if a deficiency is noted during operation which would damage the voltmeter. Record all deficiencies together with corrective action taken on applicable forms prescribed in TM 38-750. Instructions for performing the required checks are identified as periodic checks in this manual.

4-4. Checks and Services

The voltmeter shall be checked and serviced periodically in accordance with tables 4-2 and 4-3.

NOTE

If the equipment must be kept in continuous operation, check and service only those items that can be checked and serviced without disturbing operation; make the complete checks and services when the equipment can be shut down.

Table 4-2. Operator's Preventive Maintenance Checks and Services

D. During Operation

A - After Operation
Time required: 0.0

Interval and sequence No.			Item to be inspected procedure	Work time (M H)
B	D	A		
1	6		KNOBS, PUSHBUTTON SWITCHES, FUSE, INPUT-OUTPUT TERMINALS Inspect for damage, security or malfunction.	0.1
2	7		READOUT TUBES AND INDICATORS (ANNUNCIATOR) Inspect for damage and malfunction.	0.1
3			INPUT/OUTPUT TERMINALS Secure or replace as necessary any items not securely installed or broken items.	0.1
4	8		FUSE Inspect and replace defective fuse.	0.1
5			POWER CABLE Inspect and replace cracked, frayed or burned cable.	0.1

Table 4-3. Organizational Preventive Maintenance Checks and Services

Total man-hours required: 0.9

Interval and sequence No.			Item to be inspected procedure	Work time (M/H)
W	M	Q		
1			KNOBS, PUSHBUTTON SWITCHES FUSE, INPUT/OUTPUT TERMINALS Inspect for damage, security or malfunction.	0.1
2			READOUT TUBES AND INDICATORS (ANNUNCIATOR) Inspect for damage and malfunction.	0.1
	1		COVERS Repair or replace as necessary any visibly damaged covers.	0.1
	2		CHASSIS SURFACES Clean.	0.2
		1	KNOBS Secure or replace as necessary any items not securely installed or broken items.	0.1
3		2	INPUT/OUTPUT TERMINALS Secure or replace as necessary any items not securely installed or broken items.	0.1
4		3	POWER CABLE Inspect and replace cracked, frayed, or burned cables.	0.1
		4	CHASSIS FEET Inspect and replace cracked or broken feet.	0.1

Section III. TROUBLESHOOTING

4-5. General

This section contains troubleshooting instructions for the voltmeter. Any malfunction that is beyond the scope of the operator, organizational, or direct support maintenance activities to correct shall be referred to general support maintenance.

4-6. Procedure

When the voltmeter fails to operate correctly, turn it off and check the following items:

- a. Wrong control settings or improper input connections (para 3-3, 3-8, and 3-9).
- b. Damaged or incorrectly connected power cord.
- c. Defective power fuse (fig. 3-2).

Section IV. MAINTENANCE OF VOLTMETER

4-7. General

This section contains maintenance instructions applicable to operator, organizational, and direct support activities. Maintenance of the voltmeter by these activities is limited to the following items:

- a. Fuse, knob, and input connector replacement (para 4-8).
- b. Cleaning (para 4-9).
- c. Functional testing (para 4-10).

4-8. Removal/ Replacement

a. *Fuse Replacement.* The input power fuse F 1 is located on the rear panel of the voltmeter. If replacement is necessary, install a 3AGC 1/2A, 250 volt fuse.

b. *Knob Replacement.* The SAMPLE RATE, RATIO FULL SCALE, and DC ZERO knobs are replaced as follows:

- (1) Loosen setscrew using an Allen wrench and remove knob
- (2) Rotate shaft of control fully clockwise.
- (3) Install knob on control shaft and secure with Allen setscrew.
- (4) Check range of control by rotating knob. If necessary, loosen setscrew and reposition knob to obtain appropriate range; tighten setscrew as required .

c. *Input Connector Replacement.* Input connectors (binding posts) on the front or rear panel are replaced as follows:

- (1) Unscrew the binding post from the mounting stud.
- (2) Install the replacement binding post on the mounting stud and tighten as required.

4-9. Cleaning

The voltmeter should be cleaned periodically to remove accumulation of dust and dirt on its exterior sections. A soft cloth dampened in a mild solution of soap and water or anhydrous alcohol (table 4-1) can be used, as desired. Dry, low pressure air can also be used to remove dirt particles lodged between surfaces.

CAUTION

DO NOT use aromatic hydrocarbons or chlorinated solvents for cleaning. These solutions react with components on the front panel and will damage them beyond repair.

4-10. Functional Testing

The voltmeter should be checked for correct operation after any maintenance is performed. Appropriate checks are contained in paragraph 3-7. Successful completion of these checks insures that the voltmeter is again ready for operation.

CHAPTER 5

FUNCTIONING OF EQUIPMENT

Section I. BLOCK DIAGRAM ANALYSIS

5-1. Introduction

This section briefly describes major circuit functions of the voltmeter. First, the dc voltage measurement mode is discussed followed by a description of the ratio mode. Both discussions are keyed to the block diagram shown in figure 5-1.

5-2. Dc Measurement Mode

a. General. The voltmeter measures and displays (digitally) dc voltages from 0 to $\pm 1100V$. Circuitry consists of an input buffer, active filter, logic circuitry, an analog-to-digital (A/D) converter, digital display, range delay, switching circuitry, and a power supply. Circuit interface is shown in figure 5-1.

b. Buffer. The buffer (A 11) receives the dc input voltage and scales it up or down so that a fullscale input produces a 10V output to the following active filter. Selection of the IV range sets the buffer gain to 10, thus providing a 10V output for 1V input. Gain is fixed at unity in the 10V, 100V, and 1,000V ranges and the input is scaled down using an input divider. A process in the buffer yields a negative output for a positive input. The opposite is true for a negative input, which yields a positive output.

c. Active Filter. The active filter (A10) suppresses ac noise present in the buffer output. It consists of a voltage follower and a four-pole filter. Filtering is in effect when the FILTER switch is depressed. When filtering is not selected, the four-pole filter is bypassed and the circuit functions as a voltage follower. The resulting output is applied to the A/D converter.

d. Logic. The logic (A8) produces the master timing signals from which measurement periods in the voltmeter are derived. It also produces the master reference voltage upon which the voltmeter accuracy and stability is based. The circuitry consists of a master clock, a six-state shift register, a current controlled oscillator (CCO), a four-bit counter, and a +7V DC reference voltage supply. Gating signals which synchronize all timing circuitry are produced by the master clock. The shift register is driven by the master clock signal and produces digit cycle control signals for

the A/D converter. Internal reference voltage for the dc measurement mode is produced by the reference voltage supply. Function of the CCO and four-bit counter are described under the A/D converter.

e. A/D Converter. The A/D converter (A9) receives the output of the active filter, determines the polarity, and serially digitizes the input voltage. The digitizing process is controlled by commands from the logic assembly. Circuitry consists of an inverting amplifier, polarity detector, sample and hold, A/D amplifier, ladder switches, and an analog comparator.

(1) The inverting amplifier receives the positive or negative input. It inverts any positive input such that its output applied to the A/D amplifier is always negative. Polarity of this signal is sensed by the polarity detector the output of which is applied to the display section. Any output voltage from the A/D amplifier greater than V_{REF} produces an output from the analog comparator, which enables the CCO in the logic assembly to send output pulses to the binary counter. The binary counter output gates appropriate ladder switches to produce a voltage across the ladder resistors. This voltage is equal in value, but opposite in polarity, to that portion of the A/D amplifier input originally applied. As the degenerate affect of the ladder voltage causes the A/D amplifier output to fall below V_{REF} the analog comparator will no longer enable the CCO. At this point, the digitizing process for the most significant digit is complete.

(2) The remaining voltage level at the output of the A/D amplifier (voltmeter input minus the most significant digit) is then stored in the sample and hold circuit until the next logic gate enables its application to the A/D amplifier. Each decade of this recirculated remainder is then digitized in a similar fashion with one exception: The recirculated remainder voltage (now the A/D amplifier input voltage) and the ladder voltage are now the same polarity.

f. Display. The display (A14) decodes the binary counter output and digitally displays the input voltage magnitude and polarity. It also

provides a variable sample rate for control of the measurement cycle. The circuitry consists of a sample rate oscillator, range counter, decoder, and display indicators. The sample rate oscillator frequency is controlled by a SAMPLE RATE control on the front panel and determines the rate at which the input is sampled. The range counter receives autorange commands from the range delay and manual range commands from the front panel switches. The range counter applies range information to the decoder and all input signal conditioning circuitry. Range, polarity and digit information is processed in the decoder, which then produces the correct display condition in the indicators.

g. Range Delay. The range delay (A2) processes switching inputs from the front panel and produces control commands for the decoder in the display. It also produces up/down autorange commands for the range counter. The circuit consists of logic, range delay one-shot, and a pulse generator. The logic circuitry produces control signals for the pulse generator and the decoder in the display. A clock signal for the range counter in the display is produced by the pulse generator. This clock signal is required for the autorange feature. The range delay one-shot produces a programmed time delay after any range change to allow for settling time of analog signal conditioners which process the input.

h. Power Supply. Operating voltages for the

instrument are produced in the power supply (A1). The voltages produced are +200V, ±18V and +5V. Each voltage is derived from the ac input using a series regulator.

5-3. Ratio Mode

a. The ratio mode of operation is essentially the same as the dc measurement mode, with the exception of the V REF supply. In this mode of operation, an external reference voltage of ±1.0 to +100V DC is processed by the ratio input (A3) and substituted in place of V REF. The resulting digital readout is then expressed as a ratio (%) in relation to the external reference.

b. The ration assembly (A3) receives the external reference voltage (±1.0 to ±100V DC), determines its polarity and magnitude, and applies the voltage to a difference amplifier. The output of the difference amplifier is buffered and used in place of the internal v REF. Circuitry consists of a polarity detector, range detector, difference amplifier, and buffer. The polarity detector senses the polarity of the applied external reference by the use of a relay and always applies a fixed polarity voltage to the difference amplifier. The range detector senses the voltage level and conditions the difference amplifier accordingly. The difference amplifier processes the external reference and produces a corresponding voltage (+0.7 to +7.0V DC). This voltage is then buffered and applied in place of the internal V REF.

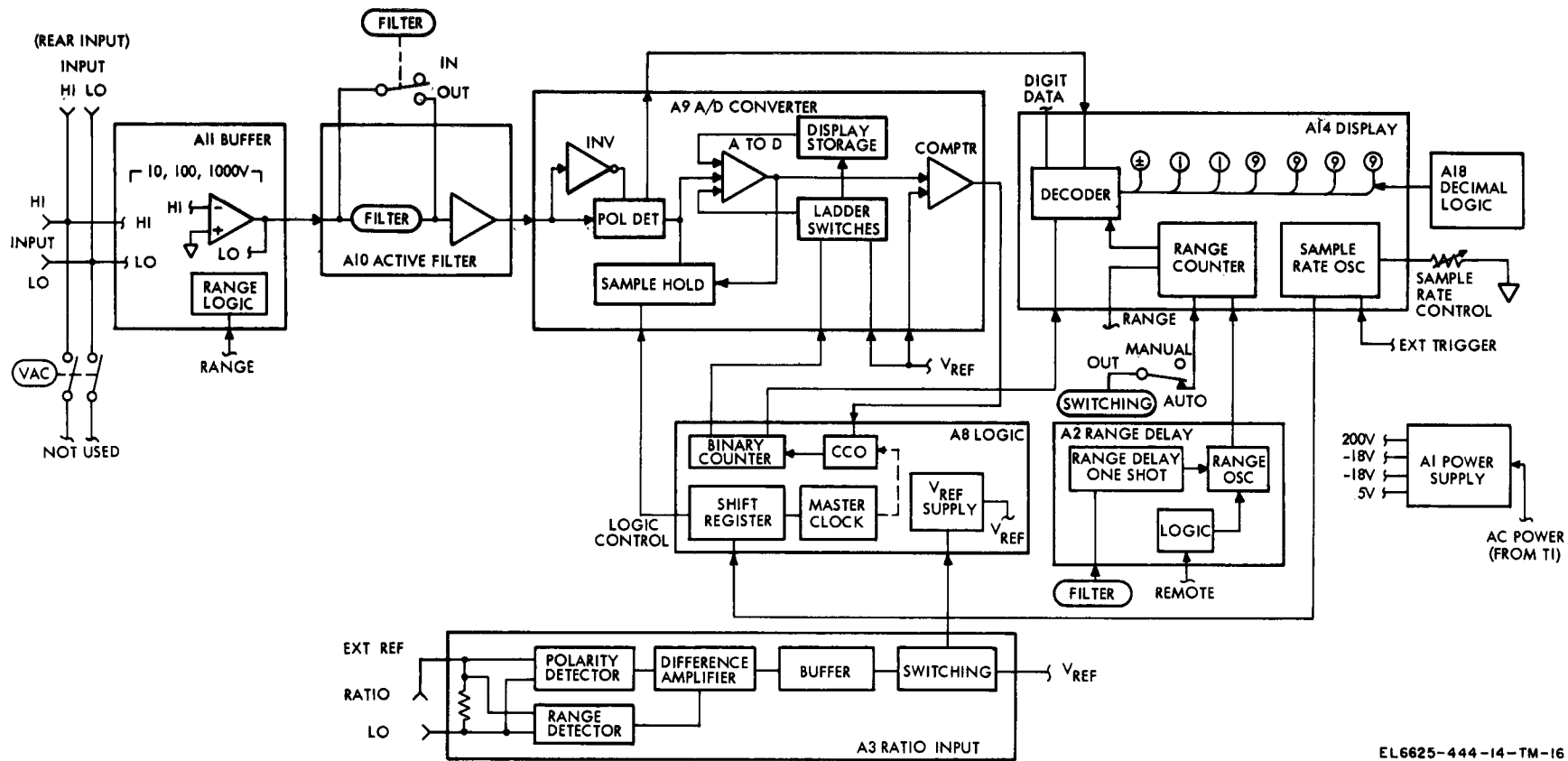

EL6625-444-14-TM-16

Figure 5-1. Voltmeter block diagram.

Section II. CIRCUIT DESCRIPTION

5-4 Introduction

This section contains detailed circuit description. Each major circuit assembly or group is described separately. All discussions are keyed to the schematic diagrams located at the rear of the manual (fig. FO-2 through FO-11).

5-5. Buffer

(fig. FO-2)

a. The buffer (A 11) provides a full-scale dc voltage of 10V DC. It consists of three basic elements: input voltage divider, amplifiers, and control logic. In the 100 and 1,000 volts range input attenuation occurs, while in the 10 volts range the input is processed without attenuation or amplification. This mode of operation is depicted in block diagram form in figure 5-2.

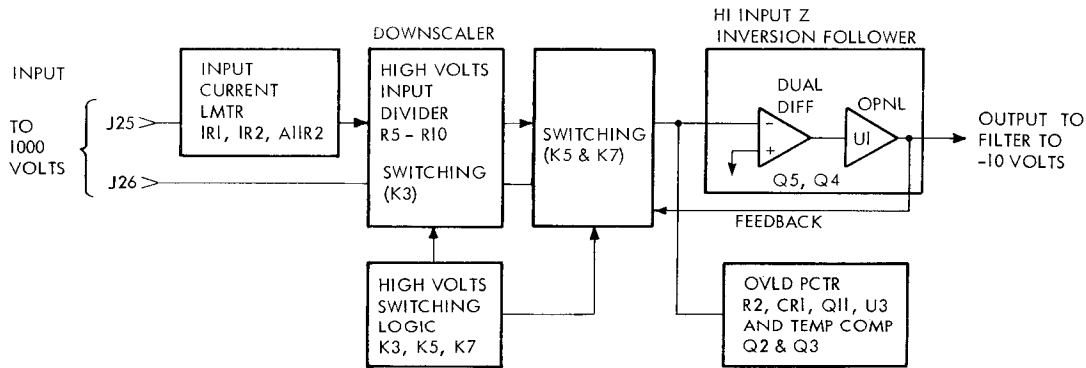

EL6625-444-14-TM-17

Figure 5-2. Buffer block diagram

b. The input to the buffer is derived from the HI and LO input jacks (J25 and J26) which are shown on the interconnect and wiring diagrams (fig. FO-10 and FO-11). Buffer input current limiting resistors 1R1 and 1R2 are also located on the system diagram, along with the high and low inputs to the buffer, at jacks J4TM and J1TR, respectively, of terminal block No. 1.

c. In the high volts mode of operation, the buffer amplifier receives the input voltage directly (10V range) or receives a scaled down voltage through an input voltage divider consisting of R5 through R10. The buffer is a unity gain inverter; therefore, its output is the inverse of the received input. For example, an input of +1000V would be scaled down to +10V through the input divider. With +10V as its input, the buffer output is -10V.

d. Any differential amplifier offset voltage present that would cause buffer output with no input is compensated by use of two potentiometers: COARSE DC ZERO, which balances the base emitter voltages of the input differential amplifier Q5 by adjusting the collector current ratio, and the second potentiometer, DC ZERO, which affords a fine adjustment via the front panel by applying just that amount of nulling

voltage to the base of differential amplifier Q5B that results in a buffer output voltage equal to zero when the input voltage is zero. This last potentiometer is labeled DC ZERO on the front panel.

e. Overload protection for dual differential amplifier Q5 is afforded by the combination of components R2, CR1, Q11, and current limiting resistors R1 and R2 shown on the system wiring diagram. Positive overvoltage protection is afforded by transistor Q11 which clamps amplifier output to 1.7 volts. Negative overvoltage protection is afforded by diode CR1 which clamps the input to -1.7 volts. The current drawn during an overload is limited by the total input resistance of 147k ohms.

f. Compensation circuits are provided to reduce the temperature coefficients of the input offset voltage and offset current. Transistor Q2 and surrounding circuitry provides through R18 and R19 the temperature varying base current required by input transistor Q5. Transistor Q3 compensates the temperature variation of the base-emitter voltage in dual transistor Q4 to insure that input transistor Q5 remains at substantially the same bias conditions regardless of temperature.

5-6. Active Filter

(fig. FO-3)

The active filter (A10) consists of a voltage follower preceded by four poles of low pass filtering. These four poles attenuate undesirable ac signals which may be present in the dc input

signal. Filtering occurs after the FILT button on the front panel is depressed. A block diagram of the active filter is shown in figure 5-3. Also shown is the response curve of the active filter which plots attenuation in decibels against a log scale of frequency in hertz.

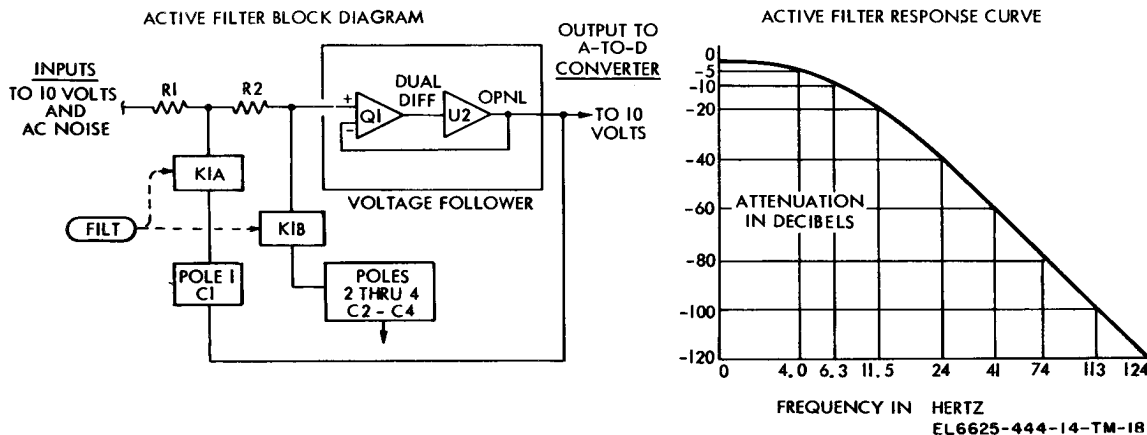

Figure 5-3. Active filter block diagram.

5-7. A/ D Converter and Logic

(fig. FO-4 and FO-5)

a. The A/D converter (A9) and logic circuits (A8) are discussed together in the following subparagraphs because any discussion of the analog-to-digital conversion process must include elements of both circuits. The basic conversion and logic circuitry involved in the conversion process is shown in figure 5-4. Also shown is an arbitrary input voltage that is the equivalent to the inverted, unknown voltage applied across the input jacks of the voltmeter. The output of the converter is shown, applied to the following stage, the display (A14) and consists of binary coded data bit groups that are serially emitted from the converter and applied to the display circuits for decoding and serial display. The basic purpose of the combined converter-logic circuitry is to convert the analog voltage input (given as +6.3524 dc volts in figure 5-4) serially by decade to binary coded bit groups, one bit group per decade.

b. The inverting amplifier consists of input switch Q3, dual FET input amplifier Q4, operational amplifier U1, and associated circuitry. Once every 18 milliseconds, during the subperiod, inverting amplifier switch Q6 is switched on by the inverting amplifier autozero drive circuit in order to zero the inverting amplifier. The drive circuit also supplies a turn-off signal to transistor Q3, thereby removing the

input to the inverting amplifier during the C subperiod.

c. The polarity detector consists of flip-flop Q10, Q11, and associated circuitry. The flip-flop employs base triggering, which is applied through diode CR6 to the base of Q10. The gate signal, gate 4, is applied to the emitters of Q10 and Q11 and enables the detector during the A subperiod of the measure period. During the remainder of the measure period, the plus and minus gates (Q8 and Q7, respectively) are turned off and the polarity information is retained by the display circuitry.

d. The A/D amplifier consists of dual FET Q20, operational amplifier U2, and associated components. Switch Q24 is turned on during the ZERO (0) sub period of the measurement period by a ZERO signal from the logic circuit. This signal also controls switches Q19 and Q31, which are turned on during the ZERO subperiod to zero the differential amplifier U2, and switch Q30, which is turned off during the ZERO subperiod to disconnect the amplifier output from the ladder. Transistor Q29 and resistor R54 constitute a clamp, which prevents amplifier U2 from saturating while its output is above 7 volts.

e. The analog comparator, consisting of transistors Q43, Q32, Q33, Q34, Q35 and associated components, is basically a voltage comparator. Differential amplifier stage Q35 compares the A/D amplifier output with the +7

volts internal reference voltage output from the ratio input assembly and differential stage Q33, Q34 outputs to the current controlled oscillator (CCO) anytime the A/D amplifier output voltage is greater than the +7 volts reference. Transistor

Q32 operates as a second comparator, which responds quickly to high voltage levels, thereby allowing maximum time for resolution of the least significant digit.

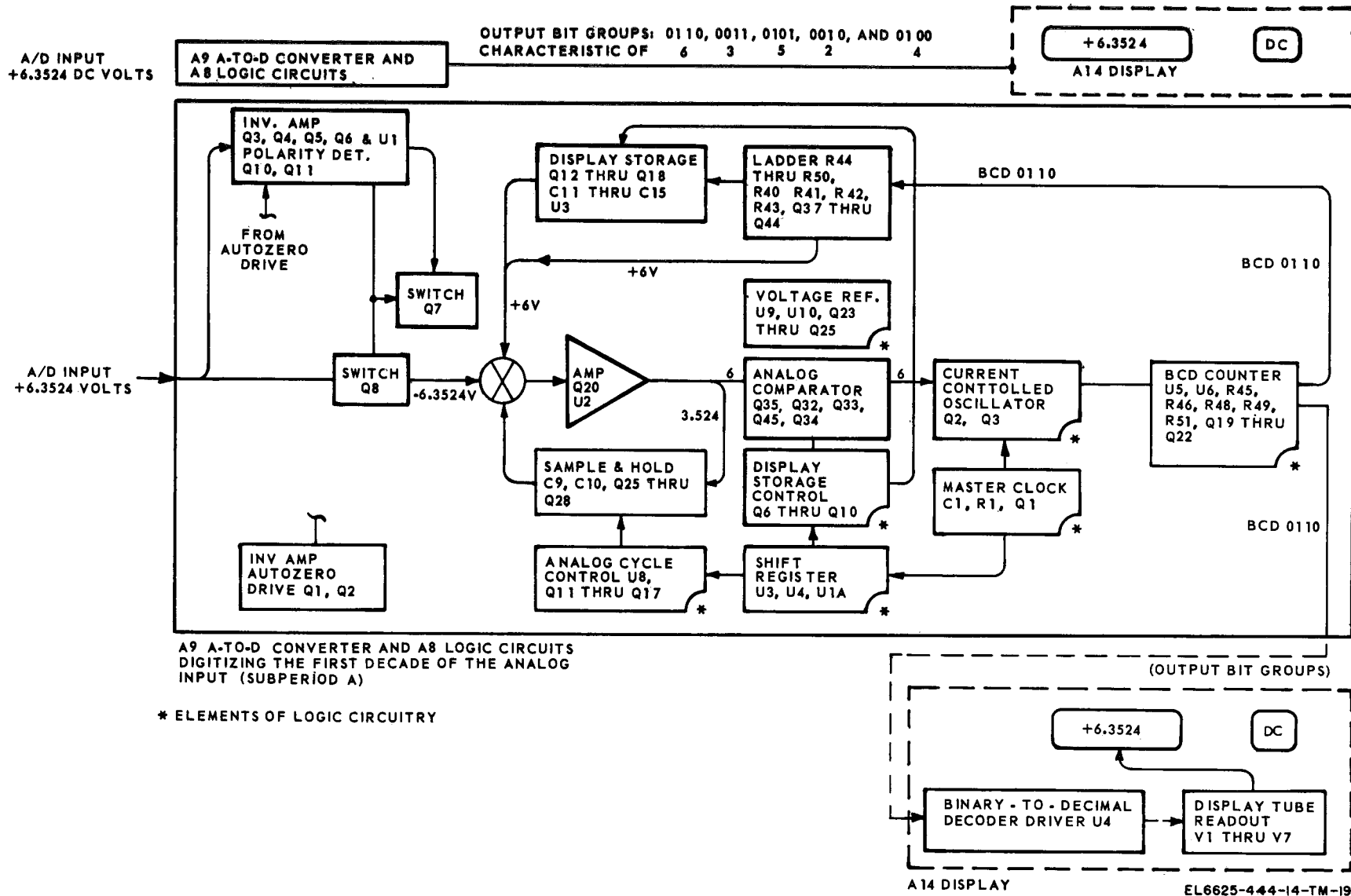

Figure 5-4. A/D converter block diagram.

f. The sample and hold circuit consists of transistors Q25 through Q28 and capacitors C9

and C10. The sequence of operation for the sample and hold circuit is shown in table 5-1.

Table 5-1. Sample and Hold Switching

Measure period subperiods	Switches on	Voltages stored on sample and hold capacitors	
		C9	C10
A	Q26, Q22	3.524	0
B	Q25, Q28	3.524	5.24
C	Q27, Q26	2.4	5.24
D	Q25, Q28	2.4	4.0
E	Q27	0	4.0
ZERO (0)	Q19, Q31, Q24	0	

NOTE

Voltages shown are only proportional to actual voltages.

g. The ladder switches of Q37 through Q44 are controlled by drivers Q19 through Q22 on the logic board (A8). The output of the ladder switches is applied to two ladders. Each ladder comprises a 4-bit, weighted-resistor, digital-to-analog converter. The primary ladder consists of resistors R44 through R50 and produces an output that corresponds to the actual value of the most significant digit of the A/D amplifier input voltage. The secondary ladder, which drives only the display storage circuit through buffer amplifier U3, consists of resistors R40 through R43 and produces an output that closely approximates the actual value of the primary ladder output. A half-digit bias is produced by R38 and R39 in conjunction with the secondary ladder resistors and adds the voltage equivalent of a half-digit to the output of the secondary ladder. This insures proper display storage readout by compensating for the effects of voltage decay in the storage circuit.

h. The display storage circuit consists of FET switches Q13 through Q17, capacitors C11 through C15, and FET switches Q12 and Q18. The buffered output of the secondary ladder is supplied to the appropriate storage capacitor through Q18, which is switched on during the second half (display time) of each subperiod. The first (most significant) digit is stored on C13, the second on C11, etc. When the cycle change circuitry switches to storage mode, Q12 is turned on

and the analog voltages stored on the storage capacitors are serially applied to the input of the A/D amplifier. Thus, the same reading is continually digitized and displayed until a new sample of the input is taken.

i. The 333 Hz clock signal is produced by transistor Q1 on the logic board (A8). The clock frequency is determined by the RC time constant of resistor R1 and capacitor C1. The output of Q1 is applied to the trigger input of flip-flop UIB. The F output of UIB is inverted in Q4 and becomes the \overline{H} signal. The F, \overline{F} , and \overline{H} signals are used by the logic to generate control signals.

j. The six-state shift register consists of J-K flip-flops U3A, U3B, U4A, U4B, and UIA. Error correction gate U2B controls the input to flip-flop U3B to insure proper operation of the shift register. At the end of a typical digitizing cycle, flip-flop UIA reverts to the ZERO condition upon receiving the \overline{H} clock pulse. All the flip-flops are now in the ZERO condition; therefore, the output of U2B goes low, thereby defining the start of the ZERO subperiod as shown in the timing diagram of figure 5-5 (1). The ZERO subperiod is terminated by the next \overline{H} clock pulse, which sets flip-flop U3B high because its J input was high and its K input was low when the clock pulse was received. Subsequent clock pulses set the flip-flop outputs as shown in table 5-2.

Table 5-2. Shift Register Outputs

Subperiod	Shift register flip-flop and zero gate					
	U3B	U3A	U4A	U4B	U1A	U2B
ZERO	0 . .	0	0	0	0	0
A	1	0	0	0	0	1
B	0	1	0	0	0	1
C	0	0	1	0	0	1
D	0	0	0	1	0	1
E	0	0	0	0	1	1

k. The 16-state binary counter consists of J-K flip-flop U5B, U5A, U6A, and U6B. The counter is set to ZERO at the beginning of each subperiod in the measurement period by the H clock pulse. During each subperiod of the digitizing cycle, the output pulses from the CCO, which are ap-

plied to the clock input of flip-flop U5B, are counted. The truth table for the flip-flops in the binary counter is shown in table 5-3. The binary counter is disabled by gate U2A if the count of 11 is attained.

Table 5-3. Sixteen-State Binary Output

Cco pulse count	Sixteen-state binary counter			
	U5B Z	U5A Y	U6A x	U6B w
0	0	0	0	0
1	1	0	0	0
2	0	1	0	0
3	1	1	0	0
4	0	0	1	0
5	1	0	1	0
6	0	1	1	0
7	1	1	1	0
8	0	0	0	1
9	1	0	0	1
10	0	1	0	1
11	1	1	0	1

l. The CCO consists of multivibrator Q2 and Q3. The CCO has no output until it is supplied current by the analog comparator and is enabled by the F output of J-K flip-flop U1B. The CCO output is applied to the clock input of the 16-state binary counter. The 9's catcher gate U7A, disables the CCO at a count of nine, if the voltmeter is digitizing the second through fifth digits (subperiods B through E).

m. The outputs of the six-state shift register, in conjunction with the H pulses of the output of Q4, are applied to the display storage control circuit consisting of transistors Q6 through Q10 and related components. Outputs from this circuitry control the display storage circuit located on the A/D converter board (A9).

n. The analog cycle control circuit produces the

gating and control signals which are used to control the synchronization of events in the analog portion of the voltmeter, principally in the A/D converter circuits. These signals, together with other control signals, are shown in figure 5-5 ②. The analog cycle control circuit consists of NAND gates U8A through D, driving transistors Q11 through Q17 and associated circuit elements.

o. The ladder switch driver circuitry (Q19 through Q22 on logic board) receives 8-4-2-1 coded binary data from the 16-state binary counter and translates this to 4-4-2-1 coded binary data, which matches the weighting of the resistors in the ladder. Thus, the ladder output is proportional to the count in the binary counter. The count increases until the output of the ladder is sufficient to bring the A/D amplifier to the

particular balanced position required by the input voltage.

p. The master +7 volts reference for the voltmeter is derived using reference amplifier U9 as a reference element. The reference voltage is produced using operational amplifier U10 and emitter follower Q25, which presents a low source impedance at the reference point. Transistor Q24 disables the +7 volts reference if the ratio mode is used and an external reference voltage is applied. Transistor Q23, coupled with the Zener in the reference amplifier, produces a reference voltage for the +18 volts regulator in the power supply (A1).

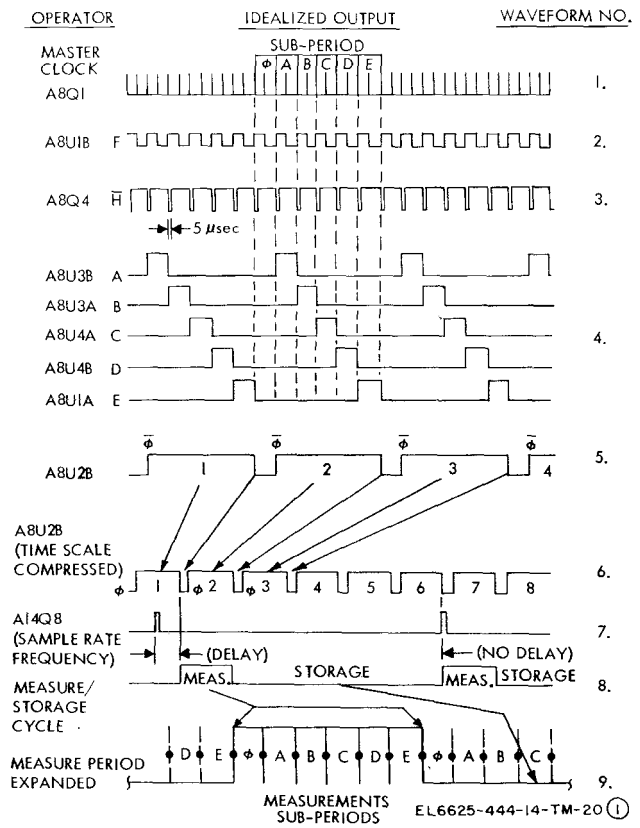

Figure 5-5 ①. Timing and synchrony diagram (sheet 1 of 3).

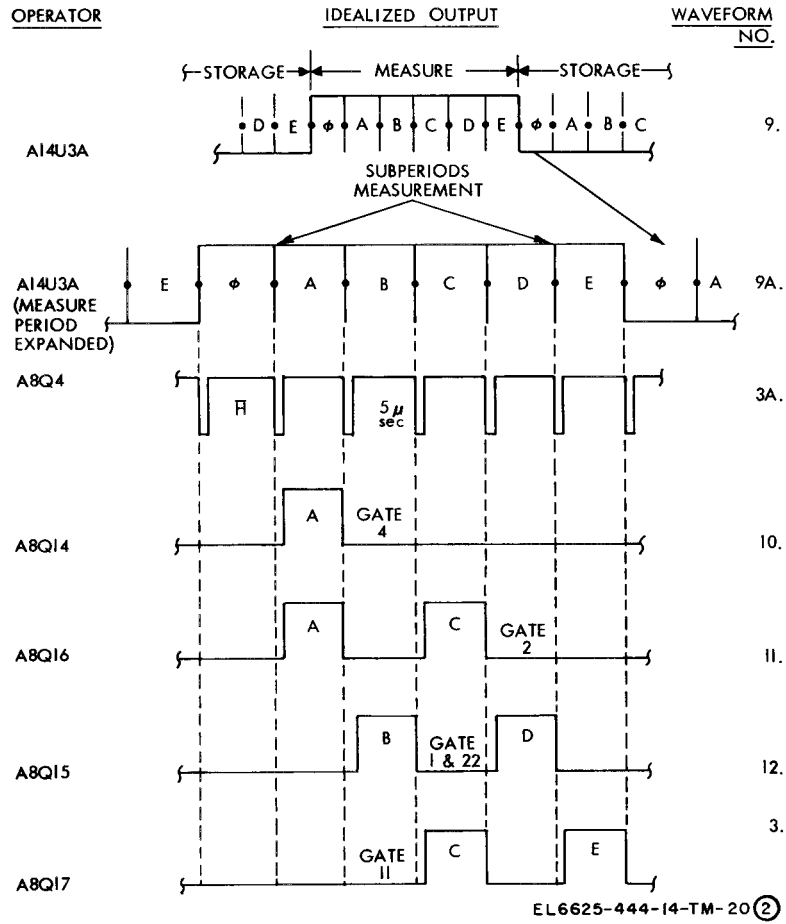
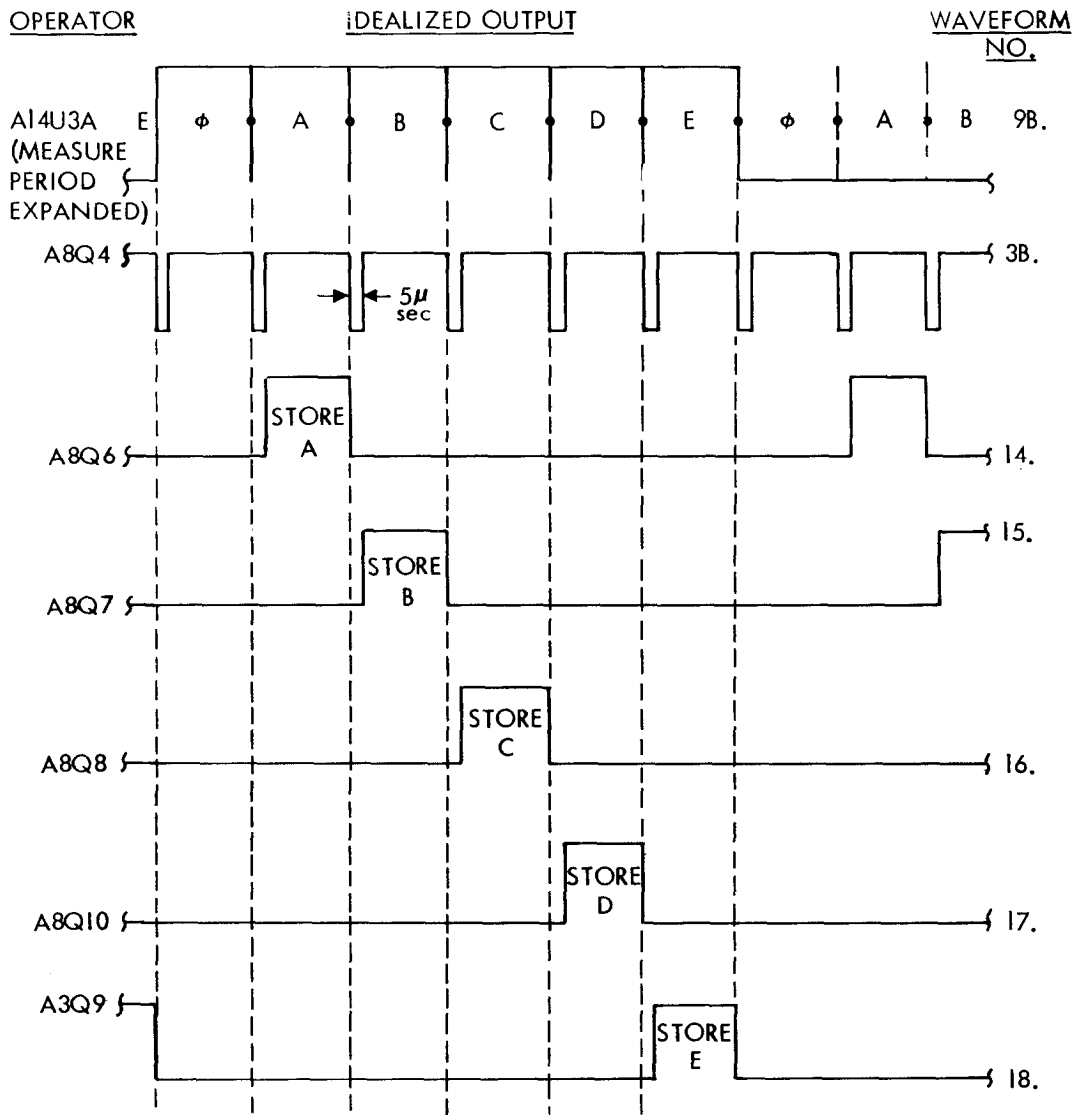

Figure 5-5 ② . Timing and synchrony diagram (sheet 2 of 3).



EL6625-444-14-TM-20(3)

Figure 5-5 (3) Timing and synchrony diagram (sheet 3 of 3).

5-8. Display

(fig. FO-6)

a. The display (A14) circuits control the function/status indicators and the decimal indicators associated with the readout tubes. The K^{Ω} , AC, DC, Ω , OVER, FILT, and % RATIO indicators are controlled by the respective function control lines. They are illuminated when +5 volts dc is applied to the control line; however, the control lines are interlocked in the associated assembly so that the indicator remains extinguished unless the assembly is installed. The overrange indicator is operated by transistor Q5 in the overrange driver circuit.

b. The polarity signs + and - of tube V1 are controlled by a flip-flop consisting of transistors Q19, Q20, FET switches Q32, Q33, current source transistors Q9, Q10, and associated components. Inputs to this circuit are VDC, C POL INFO A and B and a. POL INFO A and B come from the polarity detector in the A/D converter and determine which of the two polarity characters are illuminated. The range counter, through a, reverses the effects of POL INFO A and B as a function of range to account for the fact that the polarity detector receives the input to the instrument in its true sense on the 1-volt range, but in its inverted sense on all other ranges.

c. Switches Q22 through Q26 are the main elements of the anode strobing control circuit. They are turned on sequentially by shift register signals A through E, beginning with signal A. The \bar{F} signal insures that the transistors are turned on only during the second half of each subperiod as defined in figure 5-5(3). The output of these switches controls switches Q27 through Q31, which apply +200 volts dc to the anode of each readout tube.

d. Overrange indicator V2 is operated by transistors Q17 and Q18. These transistors are controlled by the 6-state cycle control shift register, the 16-state binary counter, and the range counter. The zero character in this tube is illuminated only when the range counter commands the 1 range, and when the count in the binary counter is less than 10. The one character is illuminated when the count in the binary counter is 10 or 11. Decoder driver U4 is a monolithic BCD to decimal decoder which accepts the 4-bit BCD output of the 16-state binary counter, decodes each digital word, and selects one of ten output drivers. The cathodes of readout tubes V3 through V7 are connected in parallel. These 10 nodes are, in turn, connected to the 10 available outputs of the decoder driver.

e. The sample command oscillator (SCO) consists of programmable unijunction transistor (PUT) Q8 and surrounding circuitry shown in figure 5-6 in its normal operating state. Resistors R12 and R14 provide a bias level for the gate of the PUT. When capacitor C3 charges to approximately 0.6 volt above the gate bias level, the PUT turns on and discharges C3 through R15. This action generates an output pulse which commands the measure/storage cycle J-K flip-flop U3A to the measure period to take a sample, if the end of a ZERO pulse is coincident at the clocked input to the flip-flop. If the sample results in a command to autorange, signal 3 from the range delay (A2) one-shot turns off Q6 and disables the SCO to allow time for analog signal conditions to settle on the new range before another sample is taken. Capacitor C3 begins to recharge and the SCO cycle begins again. The oscillator frequency is dependent upon the time constant of R and C3, and the gate bias level. The frequency is varied by the adjustment of R through the front panel SAM PLE RATE control. Transistor Q7 and its base bias network (R11 and R13) insure that PUT Q8 is turned off by forcing the gate and anode to the same potential after C3 discharges.

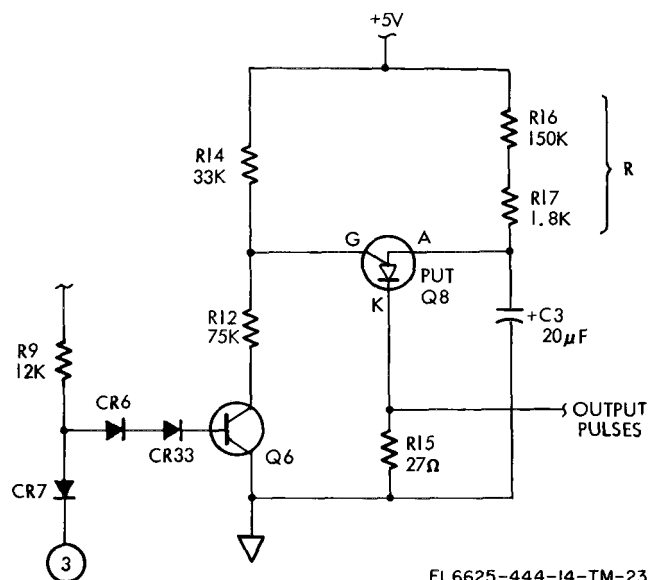

EL6625-444-14-TM-23

Figure 5-6. Basic sample command oscillator.

f. The remaining circuitry surrounding the SCO functions only when the SAMPLE RATE control is switched to the EXT position and samples are initiated through the external trigger input of the data output unit (DOU) option. In this circumstance, the emitter of Q6 is normally high. Thus, the gate of PUT Q8 is near the supply voltage and the PUT is disabled. A trigger from the DOU, however, pulls the emitter of Q6 to ground. Its collector follows, causing the gate of Q8 to be more than 0.6 volt below the anode and the PUT fires once. If the corresponding sample results in a range change, the range delay one shot multivibrator will disable the SCO through Signal No. 3 and CR7. This means that no samples may be commanded until the range delay one-shot times out. At the end of this time delay, the SCO is automatically retrIGGERED through CR8 by Signal No. 2 from the range delay one-shot. Diode CR9 and resistor R10 insure that capacitor C3 is charged rapidly to ready the PUT for the next trigger pulse. Signal No. 8 interrupts the cycle control shift register on the logic board (A8) by forcing it directly to the E subperiod. This is done to minimize the time between the sample command (trigger) and actual sample.

g. The measure/storage cycle circuit is composed of J-K flip-flop U3A. The clocked input of U3A is connected to ZERO through a bias and differentiating network composed of capacitor C4

and resistors R18, R19. When the M output of U3A is high, the voltmeter is in the measurement period of the measurement/storage cycle. When the M output from U3A is low, the storage period prevails. The clocked input is normally high as determined by the bias network, and because this is a master-slave type flip-flop, the master is connected directly to the J and K inputs and isolated from the outputs. If the SCO outputs a pulse, the J input goes high and causes the master to assume the true state. At the start of the next ZERO (0) time, the clock pulses low causing the slave, and, hence, the outputs, to assume the state of the master. That is to say, the output goes true and initiates a measure cycle. At the same time, the master is updated as a function of the new J and K inputs. Thus, at the start of the next ZERO (0) time, the slave assumes the false state existing in the master, and the storage period is initiated. Not until the SCO pulses again will another measurement period be initiated. The idealized waveform output of the measure/storage cycle J-K flip-flop is seen by viewing waveform No. 8 and its two input generating waveforms 6 and 7 in figure 5-5①.

h. The overrange driver circuit is composed of programmable unijunction transistor (PUT) Q4, transistors Q3, Q5, and Q37, and associated circuitry. Transistor Q2, diode CR5, and resistors R2 and R4 are not part of the driver circuit but constitute a delay line in the speed at which the range delay one-shot multivibrator circuit on the range delay board (A2) times out. The time-out delay is a function of the FILT button being depressed on the front panel, applying a low at the base of PNP transistor Q2, turning it on, and effectively holding transistor Q1 in the range delay one-shot off (time-out status) for a longer time than would otherwise occur if transistor Q2 were not turned on by the filtering function being activated. The overrange driver PUT Q4 is turned on when its gate voltage is depressed about 0.6 volt relative to the anode voltage. The differential voltage developed across resistor R64 (tied between the gate and anode of the PUT) when the PUT conducts turns on PNP transistor Q5, and resultingly, turns on the OVER lamp in the function display annunciator. The gate to anode voltage relationship that turns on transistor Q5 and the OVER lamp is brought about by NPN transistor Q3 when it is turned on. Transistor Q3 is turned on by the twelfth output pulse from the CCO being applied to its base. Twelve output pulses from the CCO indicate greater than 20 percent overvoltage is being applied at the input

of the instrument for a given range. However, even though turned on, transistor Q3 is ineffective in gating the PUT unless an enabling signal (\overline{UP}) is applied through R6 to its emitter. The source of the \overline{UP} signal is the output of NAND gate U2A located on the logic board (A8). Signal No. 7 is the UP range signal that is applied to NAND gate U3B on the range delay board (A2). It is generated at the emitter of transistor Q37 when this transistor is turned on by the PUT firing. After firing, the PUT is reset by the application of the positive-going edge of the M signal applied to its cathode through C1.

i. The range counter circuit is composed of J-K flip-flops U2A and U2B. The clocked input to the range counter is provided by J-K range flip-flop U3B, that has as its clocked input signal No. 6. This signal originates in the range oscillator on the range delay board (A2) and is pulsed high everytime the range oscillator PUT fires. The J-K inputs to the range flip-flop U3B are tied together at the output of the measure/storage cycle J-K flip-flop U3A and go high every measurement period. The range counter is a divide-by-6 counter that provides the six possible binary states for range counting, five pulses being considered an up-range command and one pulse being considered a down-range command. Signal No. 6 applied to the clocked input of range flip-flop U3B alters the six states of the range counter. Transistor Q35 is provided to pull the range counter out of an unallowed state that may occur at turn-on.

5-9. Range Delay

(fig. FO-7)

a. Range delay circuit (A2) consists of a series of gates, a range delay one-shot multivibrator, and a range oscillator. The gates allow the specified set of ranges to be attained, which is dependent upon the function called on the front panel. The range oscillator generates pulses which trigger the range delay one-shot while simultaneously causing the range counter (A 14) to change states. The range delay one-shot prevents further ranging for a specified time to allow the analog signal conditioners to settle in the new range.

b. The gates are U2A, U2B, U2C, U3A, and U3B. Gates U2C and U3A are up-range stops which pull down on the range-up enable line. Gate U2C stops the internal ranging from going above a 10,000 range while gate U3A prevents autoranging above the 1,000 range on the VDC function. Gates U2A and U2B are down range stops which pull down on the range-down enable

line. Gate U2A prevents autoranging below the range in the VDC function, while gate U2B prevents autoranging below the 1 range in any function. Gate U3B is the master up-range control. It enables the range oscillator only if an up-range is to be expected.

c. Inverters U1D, U1E, and U1F coupled with the range-up enable line, provide one input for up-range control gate U3B. The result is that U3B is enabled for 1.5 milliseconds (the second half of the A subperiod of a measurement period) if an up-range is to be executed. Signals applied to diodes CM through CR8 and CR10, coupled with the range-down enable line provide a negative going signal to the range oscillator at the end of the A subperiod of a measurement period if a down-range is to be executed. Thus, there are two ways which can enable the range oscillator.

d. The range oscillator is composed of capacitor C4, resistors R14, and programmable unijunction transistor (PUT) Q4, with the output of this oscillator appearing at the cathode of PUT Q4. The PUT is fired, discharging capacitor C4 through resistor R15, when the gate is about -0.6 volt relative of the anode. Thus the PUT is fired to produce one output pulse by lowering gate voltage or by raising the anode voltage, such that the voltage difference between these elements is as indicated above. The firing of PUT Q4 discharges capacitor C4 and reduces the anode and gate voltages. This action causes Q3 to turn on and force the anode and gate of Q4 to the same potential. Transistor Q4 turns off and capacitor C4 charges through R14. If the firing potential between the gate and anode of Q4 is established, Q4 again fires and the cycle is repeated to produce the second output pulse. The frequency of oscillations is set by the level of gate voltage applied and the charging time constant of R14 and capacitor C4.

e. Control of the gate of PUT Q4 is effected by one of two mutually exclusive inputs. One of these is associated with ranging up and is identified on the A2 schematic diagram as the output of gate U3B. The other of the two inputs is associated with ranging down and is identified as the range down enable line. In an up-range situation, the output of U3B pulls low for 1.5 milliseconds during which time the range oscillator outputs five pulses. In a down-range situation, the range-down enable line pulls low. This signal is capacitively coupled through C3 to the gate of PUT Q4 causing it to output one pulse. Five pulses counted by the range counter (A14) command a transition to the next higher range, while one pulse commands a transition to

the next lower range. In either case, the first output pulse triggers the range delay one-shot to allow the analog signal conditioners to settle in the new range.

f. Transistors Q1, Q2, and associated components make up the range delay one-shot multivibrator. A range change pulse from the range oscillator applied to the base of transistor Q2 turns this transistor on and transistor Q1 off, thereby placing the one-shot multivibrator into its unstable state. The RC charge time of combined capacitors C2, C6, and resistor R5, and the current through R16 determine how long the one-shot remains in its unstable state. With the filter selected, no current flows through R16 and the timeout is about 220 milliseconds. Without the filter selected, the timeout is decreased to about 25 milliseconds because some current flows through R16. Signal No. 3 disables the sample command oscillator during the range delay item. Signal No. 2 retriggers the SCO at the end of the range delay time.

g. Transistor Q5 and associated components is a circuit that prevents the instrument remaining in a disallowed range, as in 10,000 VDC, when turned on. When Q5 is turned on by the inputs of VDC and $\bar{a} \cdot \bar{b} \cdot \bar{c}$, the collector of Q5 pulls down on the set line of the counter and thereby forces the instrument out of the 10,000 range.

5-10. Power Supply.

(fig. FO-8)

a. Power supply (A1) consists of four regulators: a + and - 18 volts regulator; a 200 volts regulator; a 5 volts regulator. The power supply furnishes all required operating power.

b. The +18- and -18-volt regulators obtain filtered dc voltage from the full-wave rectifiers consisting of diodes CR5 through CR8 and filter capacitors C2 and C5. The +18 volts regulator consists of operational amplifier U1 and series pass transistor Q3. The voltage reference for the +18 volts regulator is derived from reference amplifier U9 and temperature compensation transistor Q23 on the logic board (A8). The -18 volts regulator consists of operational amplifier U2 and series pass transistor Q5. The -18 volts regulator is referenced to the +18 volts.

c. The +200 volts regulator is operated from a full-wave bridge rectifier and filter consisting of diodes CR1 through CR4 and capacitor C1. The reference for the +200 volts regulator is the +18 volts. Voltage variations are amplified in transistor Q2 and applied to series pass transistor Q1.

d. The +5 volts regulator is operated from a full-wave rectifier and filter consisting of CR10

through CR13 and capacitor C8. The reference for the +5 volts regulator is -18 volts. The series pass element is a compound-emitter follower composed of transistor Q8 driving power transistor Q6. Voltage variation which are detected by the sample string (R14, R15 and R17) are amplified by transistors Q7.

5-11. Ratio Input

(fig. FO-9)

a. The ratio assembly (A3) supplies an internal reference voltage from an external reference source. Circuitry consists of a polarity detector, a range detector, a difference amplifier, and a buffer amplifier.

b. The polarity detector applies a fixed polarity signal to the difference amplifier circuitry. The polarity detector consists of operational amplifier U2 transistor, Q2, relay K1 and associated circuitry. The operational amplifier senses the polarity of the external reference signal and controls the base voltage of Q2. Transistor Q2 will activate relay K1 when the base is driven positive. The signal at the external reference terminals is applied to the difference amplifier through the contacts of relay K1.

c. The range detector senses the external reference voltage and conditions the difference amplifier for operation in one of two ranges: 1V to 10V; 10V to 100V. The range detector consists of operational amplifiers U1, U3, U4, U5, U6, transistor Q1 and relay K2 and associated circuitry. A portion of the external reference signal is applied to the range detector circuitry through high impedance follower for isolation from the range detector circuitry. Amplifier U3 is wired as a difference amplifier with a unity gain. Amplifiers U4 and U5 (combined) are an absolute value amplifier. The output of the absolute value amplifier is equal to the input in value but is always positive polarity whereas the input may be positive or negative. Operational amplifier U6 controls the base of Q1 which in turn controls the activity of relay K2. Relay K2 energizes when the external reference voltage exceeds 10.5 volts.

d. The difference amplifier circuitry converts the external reference signal to a dc voltage between +0.7 to +7V dc. The difference amplifier consists of operational amplifier U7, resistors R1 through R12, and relay contacts K2A and B. The gain of U7 is 0.7, which is set through resistors R1, R2, R3 and R4 with an external reference of 1 to 10.5V. Resistors R5 and R6 parallel R4 when relay K2 is energized, thereby changing the gain of U7 to 0.07 when the external reference voltage is between +10.5 and 100V dc. Resistors R7, R8, R9, R10 and R11 and R12 are the reference leg for U7 positive terminal.

e. The buffer amplifier is an impedance device used to isolate the ratio input circuitry. The buffer amplifier consists of FET Q5, operational amplifier U8, transistor Q6 and associated circuitry. Transistors Q5 and Q6 control the input terminals of U8, R21, R23, and R24 which are used in conjunction with R22 to correct an offset voltage on the input terminals of U8.

f. RATIO FULL SCALE potentiometer, transistors Q3 and Q4, provides a full scale adjustment of +50 and -50 digits in the readout. The conduction of Q3 is subsequently varied by adjustment of the FULL SCALE RATIO control.

5-12. Decimal Logic

(fig. 5-7 and 5-8)

The purpose of the decimal logic assembly (A18) is to properly position the decimal in the readout. Transistors Q8 and Q9 and range command signals c and \bar{c} control NOR GATES U1A through U1D so that two low signals appear on the inputs to only one NOR GATE at a given time. The NOR GATE outputs are applied to transistors Q1 through Q7 and Q10. Range command signals \bar{a} , b , and \bar{b} , plus the output of the NOR GATES, determine which transistor (Q1 through Q7 and Q10) will be turned on, thereby controlling selection of which display tube will display a decimal. Figure 5-7 is a truth table for NOR GATES U1A through U1D and also shows conditions necessary to turn on Q1 through Q7 and Q10.

DECIMAL LOGIC CONDITION

VOLTMETER CONDITION								
FUNCTION	EXT REF VOLTAGE	RANGE CALLED	COLLECTOR		c	ε	ON XSTR	
			Q8	Q9				
VAC*	±1V TO ±10.5V	1	1	0	0	1	Q1	
VDC, VAC		10	1	0	1	0	Q2	
VDC, VAC		100	1	0	0	1	Q3	
VDC, VAC		1000	1	0	1	0	Q4	
RATIO		1	0	1	0	1	Q10	
RATIO		10	0	1	1	0	Q5	
RATIO		100	0	1	0	1	Q6	
RATIO		1000	0	1	1	0	Q7	
RATIO		±10.6V TO ±100V	1	1	0	0	1	Q1
RATIO			10	1	0	1	0	Q2
RATIO	100		1	0	0	1	Q3	
RATIO	1000		1	0	1	0	Q4	

NOTES: *AC Converter (-01 Option) installed
 CODE: 1 = HI
 0 = LO

NOR GATE TRUTH TABLE

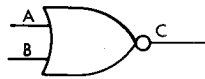

A	B	C
0	0	1
1	0	0
0	1	0
1	1	0

0 = LO
 1 = HI

EL6625-444-14-TM-24

Figure 5-7. Decimal logic truth tables.

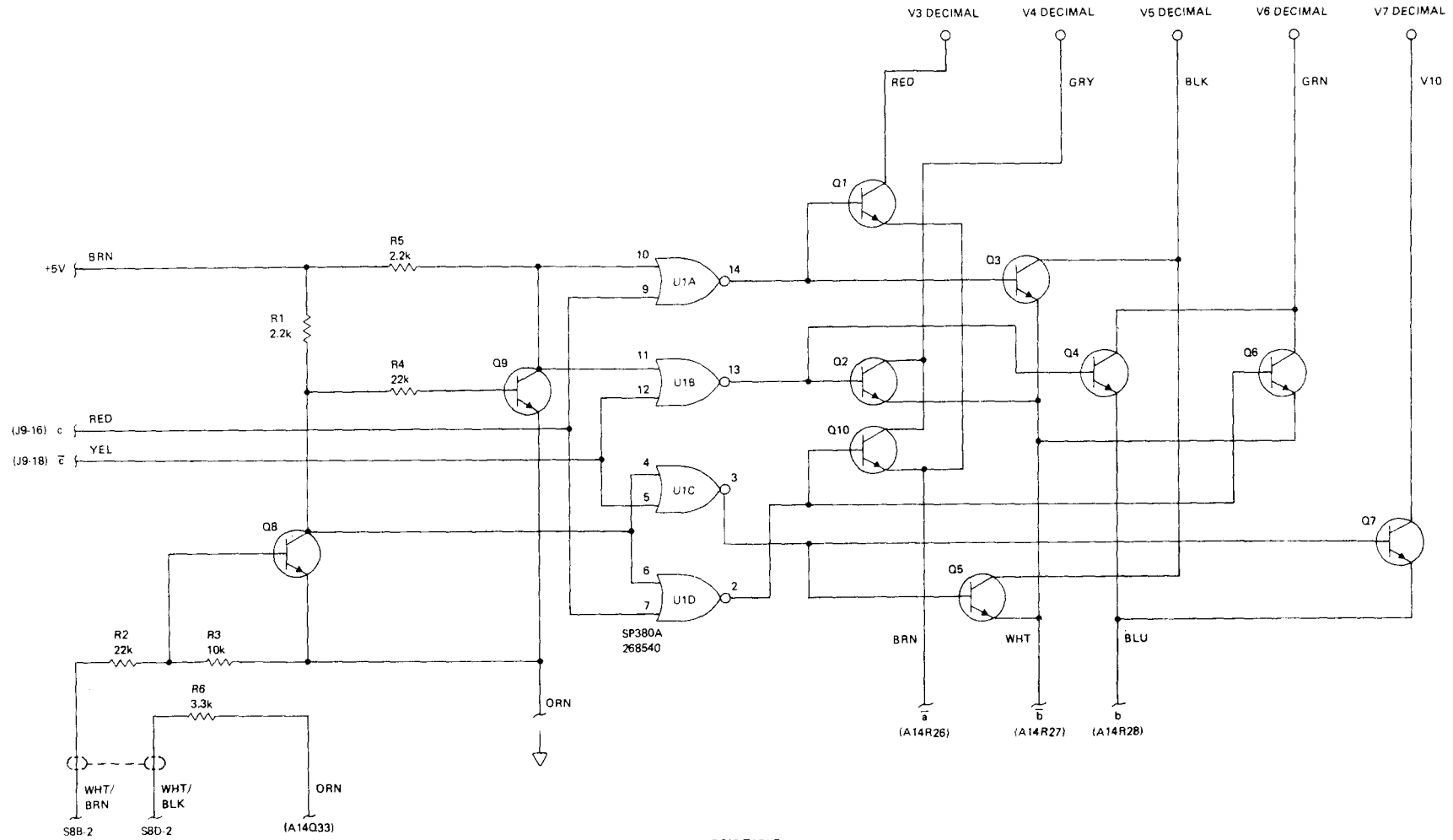

LOGIC TABLE

RANGE	a	b	c	a	b	c
000	0	0	1	a	b	c
100	0	1	0	a	b	c-bar
10	0	1	1	a	b	c
1	1	0	0	a	b	c

EL6625-444-14-TM-60

Figure 5-8. Decimal logic (A18), schematic diagram.

5-13. Miscellaneous Circuitry

(fig. FO-10 and FO-11)

Input power to the instrument and interconnection of various assemblies is shown in the interconnect and wiring diagrams (fig. FO-10 and FO-11). Line power is fused by F1 and applied through the contacts of POWER switch S1 and transformer T1. The primary of T1 consists of two windings which are parallel or series connected through slide switch S2 to allow operation

from either a 115 or 230V ac line. When S2 is set to 115, the primary windings of T1 are connected in parallel. The 230 position of S2 connects the windings in series. Secondary windings of T1 provide ac voltages to the power supply (A1) and optional data output unit No. 2 (A6). Shielding between the primary and secondary windings prevents coupling of any undesired line signals to the internal sections of the voltmeter.

CHAPTER 6

GENERAL SUPPORT MAINTENANCE

Section I. GENERAL

6-1. Introduction

This section contains voltage and waveform diagrams. It also contains part location, test point, and adjustment location diagrams.

6-2. Voltage and Waveform Diagrams

Applicable voltages appearing throughout most

of the voltmeter are contained in tables 6-1 through 6-6. This information was taken under specific conditions referenced in tables 6-1 through 6-6. Voltages and waveforms applicable to the logic circuitry are contained in the troubleshooting section, section III.

Table 6-1. Power Supply (A1) Voltage Measurements

Power supply (A1)			
Test points	VDC		
TP1	+2.0	NOTE All measurements referenced to A1TP4(-).	
TP2	+18.0		
TP3	-18.0		
TP5	+ 5.0		
Transistor (VDC)		Collector	Emitter
Q1	+260	+199	+ 200
Q2	+199	+18.5	+ 18.0
Q3	+25	+18.5	+ 18.0
Q5	-27	+18.5	-18.0
Q6	+8.0	+5.7	+5.0
Q7	+6.5	+0.62	0
Q8	+8.0	+6.5	+5.7

Table 6-2. Range Delay (A2) Voltage Measurements

Range delay (A2)				
Test points	VDC			
TP1	+0.1	NOTE All measurement referenced to A8TP1(-), INPUT terminals shorted and controls as follows: MODE		
TP2	+0.53		 VDC; FILTER OUT
TP3	+5.0			RANGE
				SAM PLE RATE
	100as desired	
Transistor (VDC)		Collector	Base	Emiller
Q1	+0.1	+0.7		0
Q2	+4.75	+0.3		0
Q3	+5.0	+1.8		+5.0
Q5	+5.0	+0.5		+0.9
Q6	+5.0 (A)		+5.0 (G)	+0.3 (K)

Table 6-3. Ratio Input (A3) Voltage Measurements

Ratio input (A3)	
Test points	VDC
TP1	-18.0 to +2.5
TP2	(*)
TP3	(*)
TP4	(*)
TP5	(*)
TP6	(*)
TP7	(*)
TP8	-18.0

NOTE
All measurements referenced to A9TP7(-), EXT REF and INPUT terminals shorted, and controls as follows:
MODE RATIO, FILTER OUT
RANGE 10
SAMPLE RATE as desired

				Emitter
Q1	N/A	N/A	N/A	N/A
Q2	N/A	N/A	N/A	N/A
Q3	N/A	N/A	N/A	N/A
Q4	N/A	N/A	N/A	N/A
Q5	N/A	N/A	N/A	N/A
Q6	N/A	+15.4	+16.0	+16.0
Q7	N/A	-14.9	-15.4	-15.4
Q8	N/A	N/A	N/A	N/A
Q9	N/A	N/A	N/A	N/A
Q10	N/A	N/A	N/A	N/A

Table 6-4. Logic (A8) Voltage Measurements

Logic (A8)			
TP2	+4.5		
TP3	+0.09 or +3.8		
<p style="text-align: right;">NOTE All measurements referenced to A8TP1 (-), INPUT terminals shorted, GUARD disconnected, and controls as follows: MODE VDC, FILTER RANGE 100 SAMPLE RATE Counterclockwise</p>			
Transistor (VDC)	Collector	Base	Emitter
Q1	N/A	N/A	N/A
Q2	N/A	N/A	N/A
Q3	+0.17	+0.705	0
Q4	+4.7	0	0
Q5	+4.9	-0.04	+0.18
Q22	N/A	N/A	N/A
Q23	+6.58	+6.58	+6.02
Q24	+8.0	0	0
Q25	+18.0	+7.54	+6.91

Table 6-5. Active Filter (A10) Voltage Measurements

Active filter (A10)				
Test points	VDC	NOTE		
TP1	+2.35	All measurements referenced to A 10TP4(·). INPUT terminals shorted, GUARD disconnected, controls as follows: MODE VDC, FILTER RANGE 100 SAMPLE RATE as desired		
TP2	+2.30			
TP3	0			
TP5	0			
	Transistor (VDC)	Collector	Base	Emitter
Q1A		+0.247	0	-0.51
Q1B		+0.247	0	-0.51
Q2		-0.51	-14.9	-15.4
Q3		+2.4	+15.4	+16.0

Table 6-6. Buffer (A11) Voltage Measurements

Buffer (A11)				
Test points	VDC	NOTE		
TP1	N/A	All measurements referenced to A11TP2(-), INPUT terminals shorted, GUARD disconnected, controls as follows: MO D E VDC, FILTER RANGE 100 SAM PLE RATE as desired		
	Transistor (VDC)	Collector	Base	Em
Q1		+2.84	+7.74	+8.41
Q2		0	0	+0.16
Q3		+0.49	+0.49	0
Q4		+0.69	+0.49	+0.12
Q5		+0.12	0	-0.45
Q6		+5.1	N/A	+4.9
Q7		+4.7	N/A	+4.9
Q8		+0.1	N/A	+4.9
Q11		-18.0	0	0

NOTE

All voltages measured with battery powered differential voltmeter (table 6-1).

6-3. Schematic Diagrams

A schematic diagram of each assembly in the voltmeter is contained in figures FO-2 through FO-9. An interconnect diagram and wiring diagram is shown in figures FO-10 and FO-11, respectively. All diagrams are located at the rear of this manual

6-4. Part Locations

Location of assemblies and troubleshooting test points are shown in figure 6-1. Calibration adjustment and test point locations are shown in figure 6-2. Component part locations in each assembly are shown in figures 6-3 through 6-13.

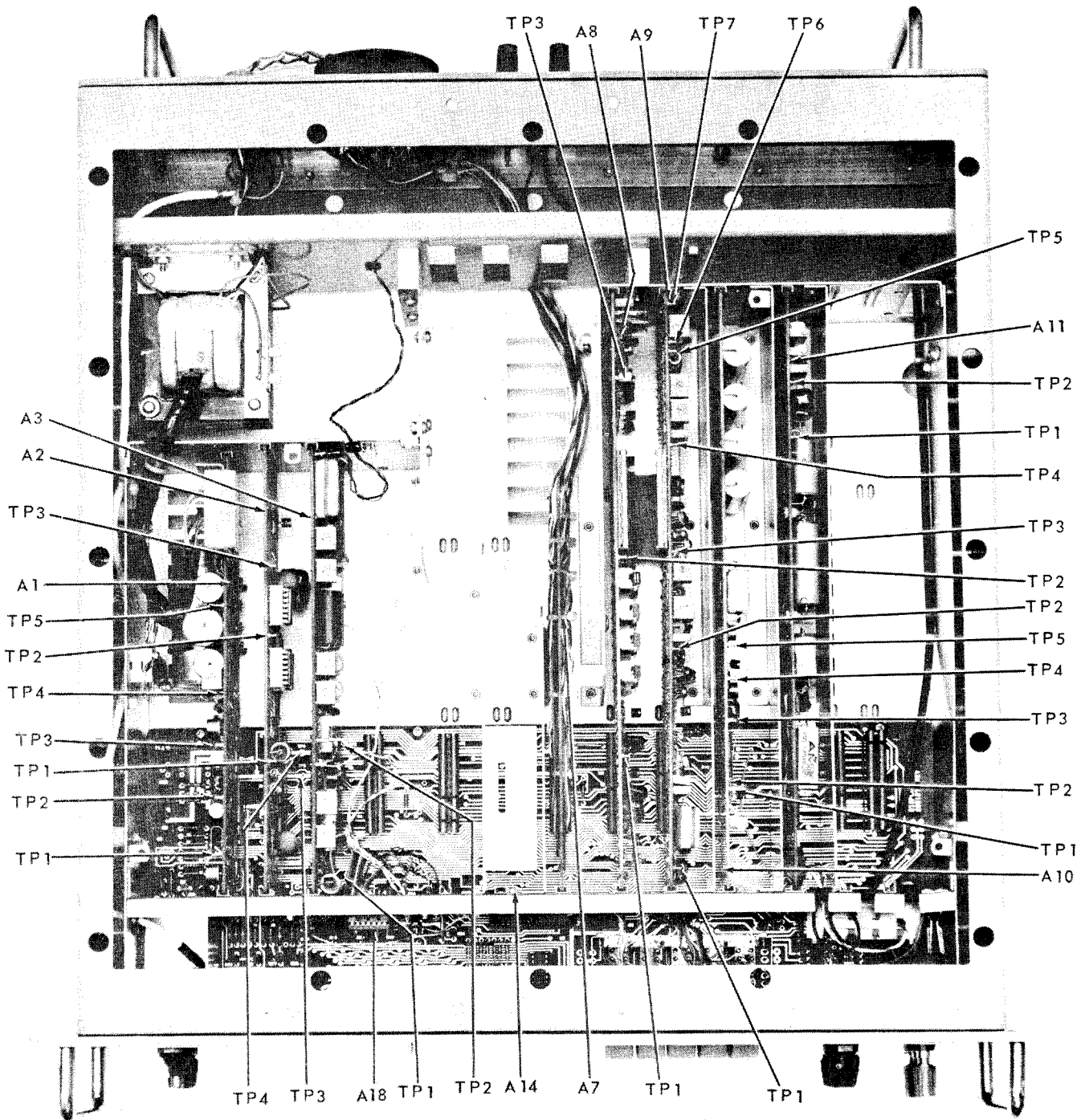

EL-6625-444-14-TM-25

Figure 6-1. Assembly and troubleshooting test point locations.

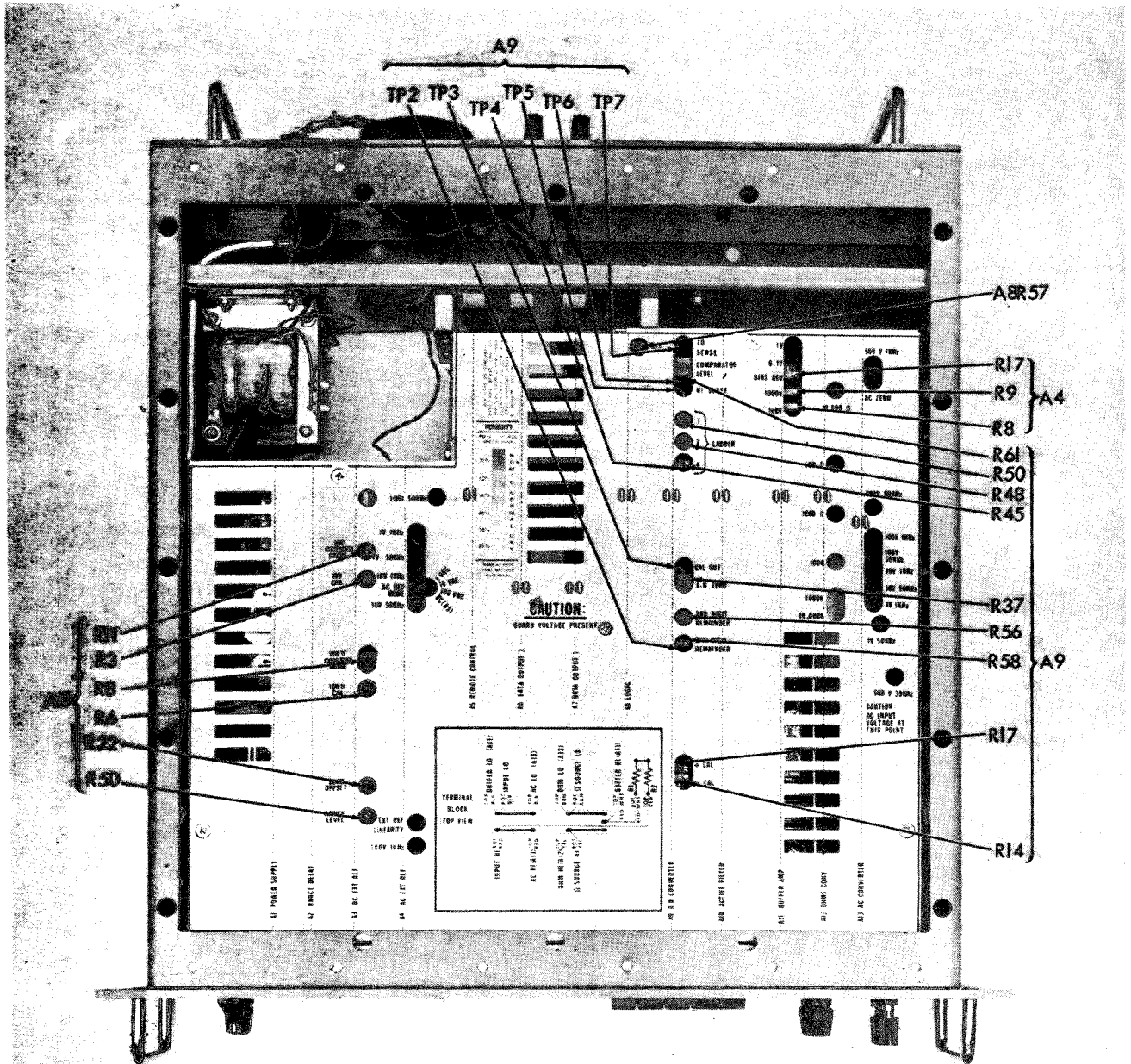

EL 6625-444-14-TM-26

Figure 6-2. Alignment adjustment and test point locations.

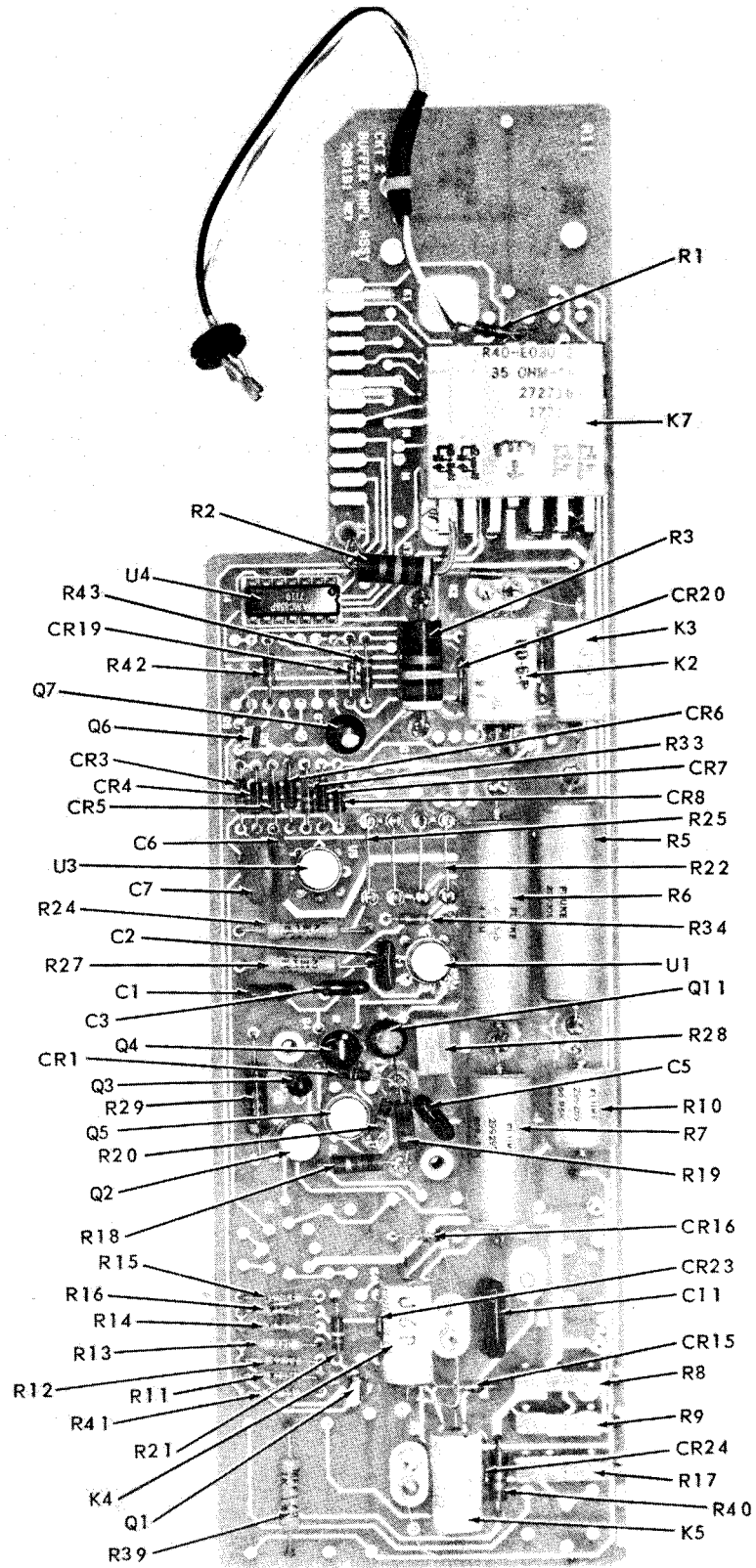

Figure 6-3. Buffer (A11) component parts.

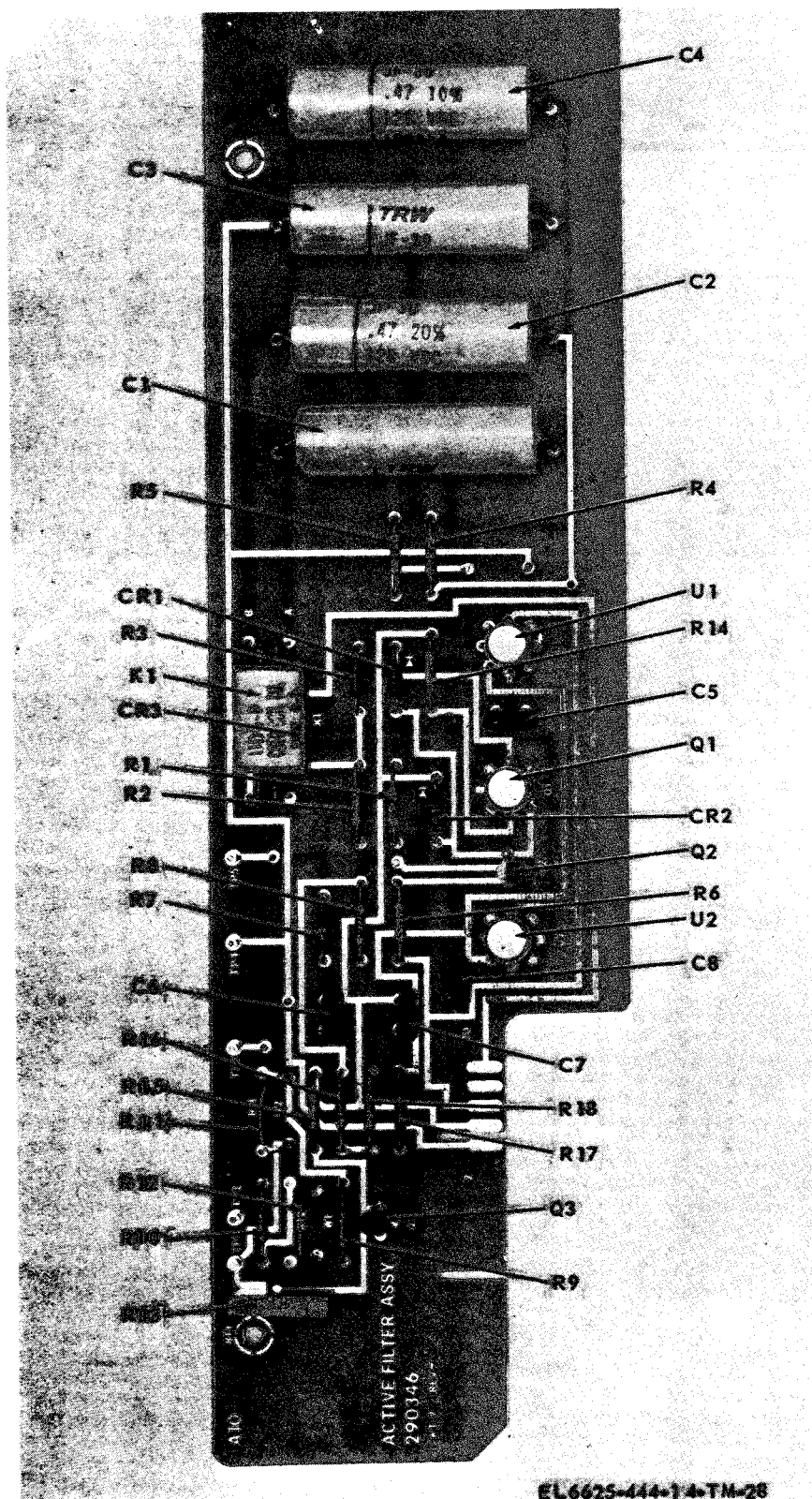
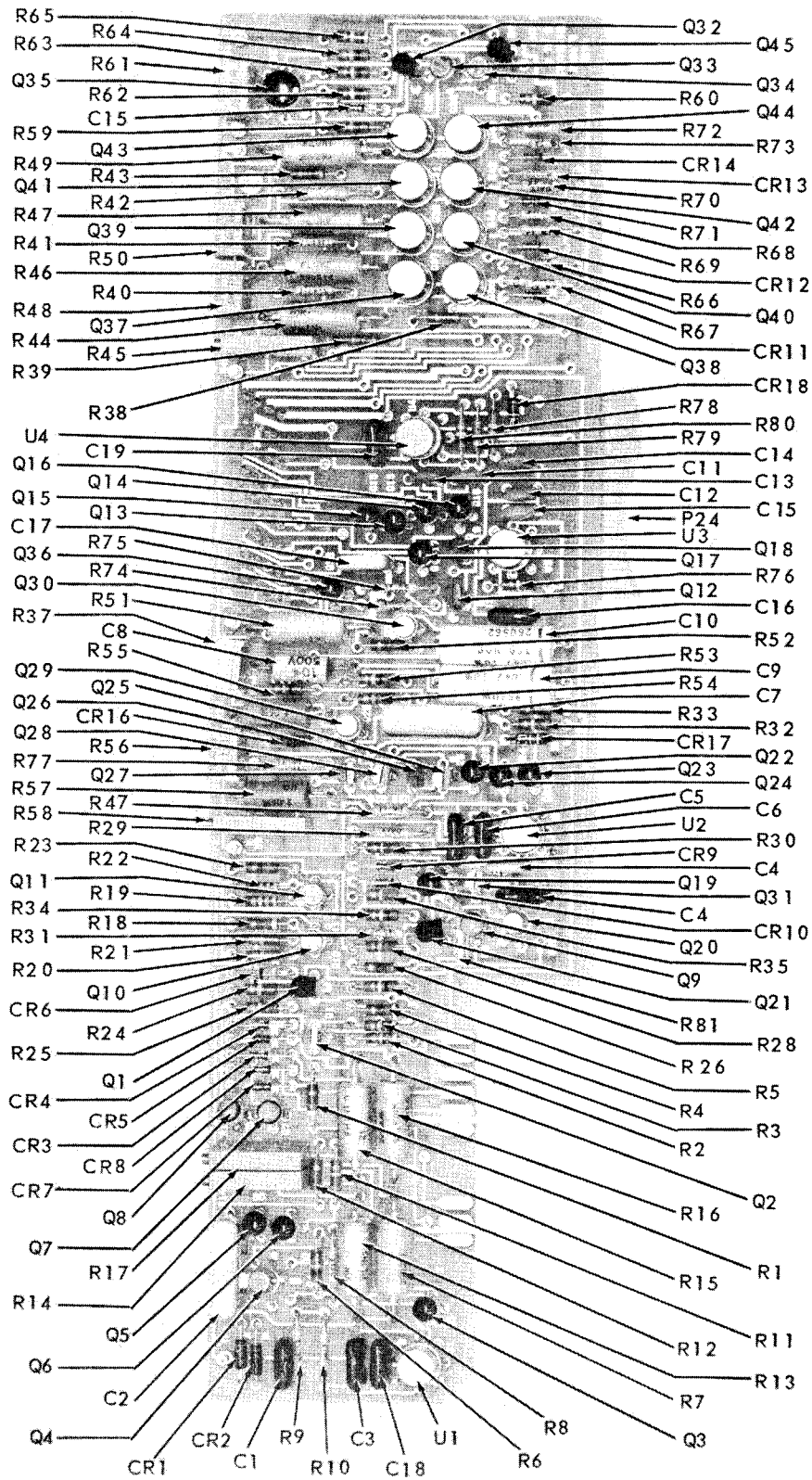
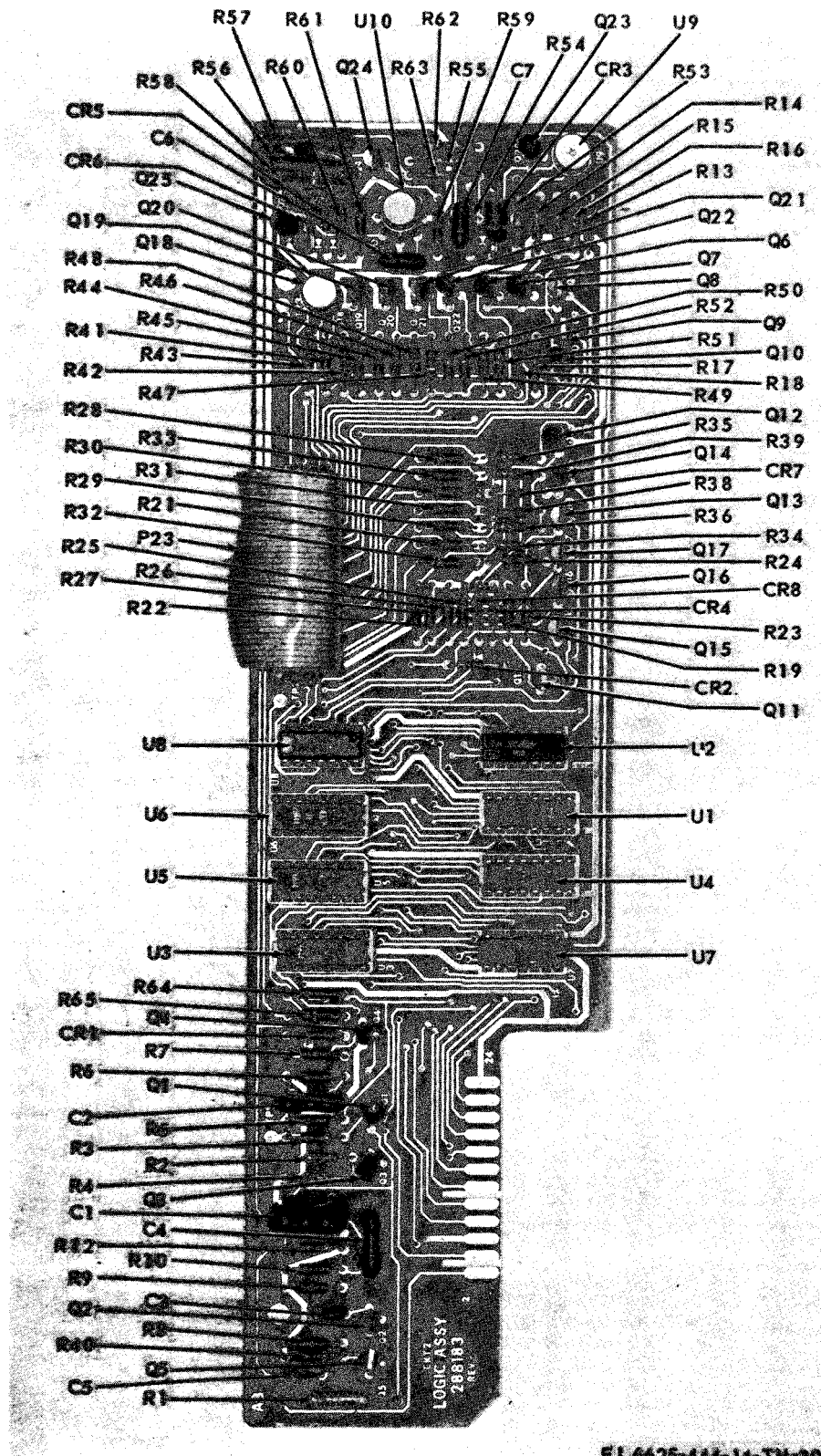

Figure 6-4. Active filter (A10) component parts.



EL-6625-444-14-TM-29

Figure 6-5. A-to-D converter (A9) component parts.



E L 6625-444-14-TM-30

Figure 6-6. Logic (A8) component parts.

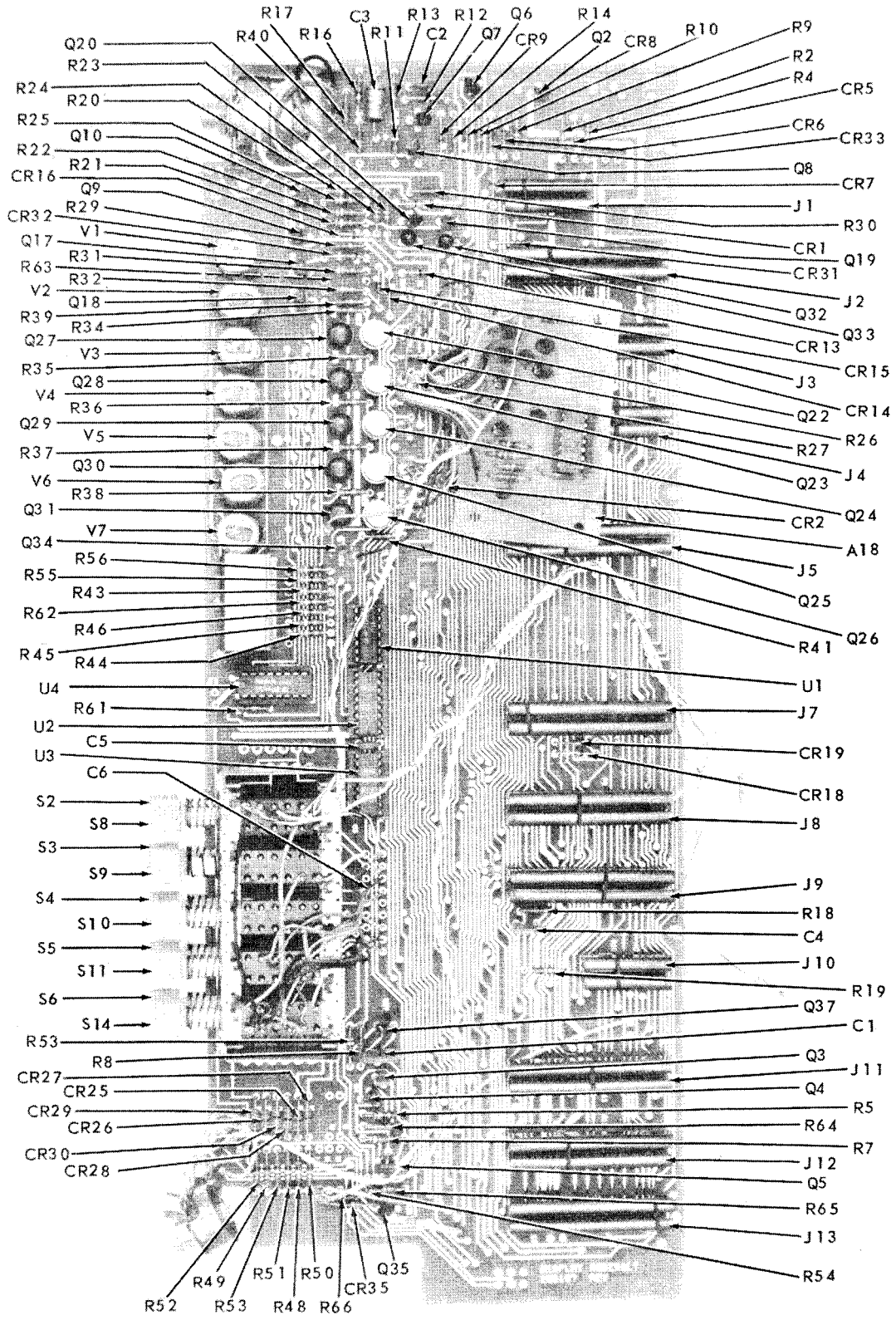

EL-6625-444-14-TM-31

Figure 6-7. Display (A14) component parts.

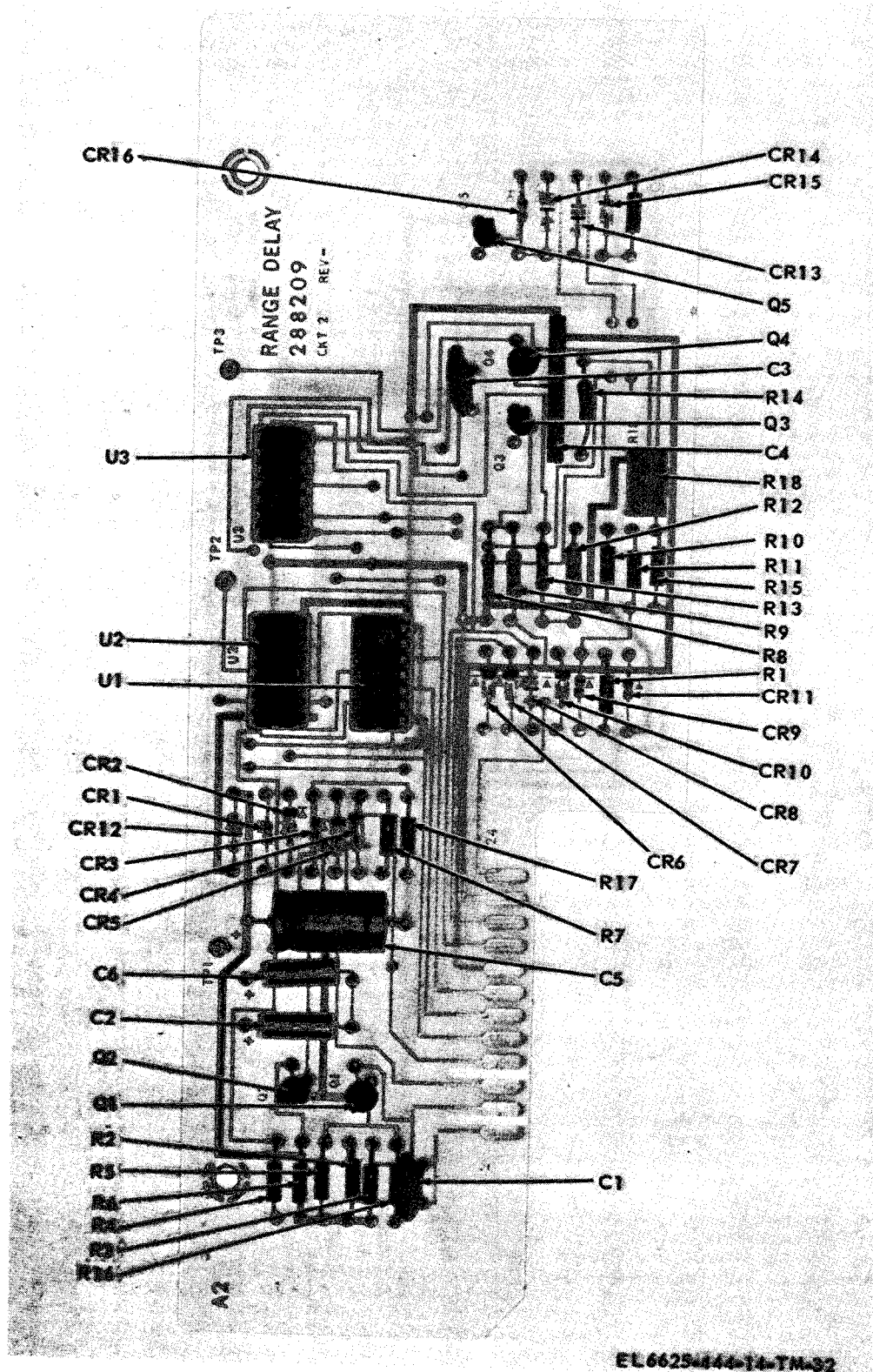
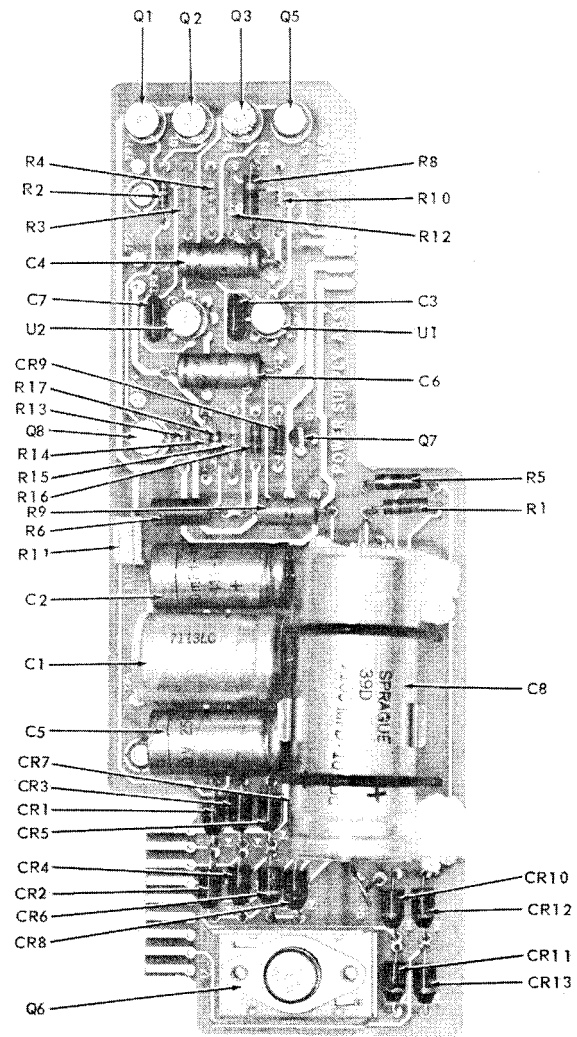

Figure 6-8. Range delay (A2) component parts.



FL 6625-444-14-TM-33

Figure 6-9. Power supply (A1) component parts.

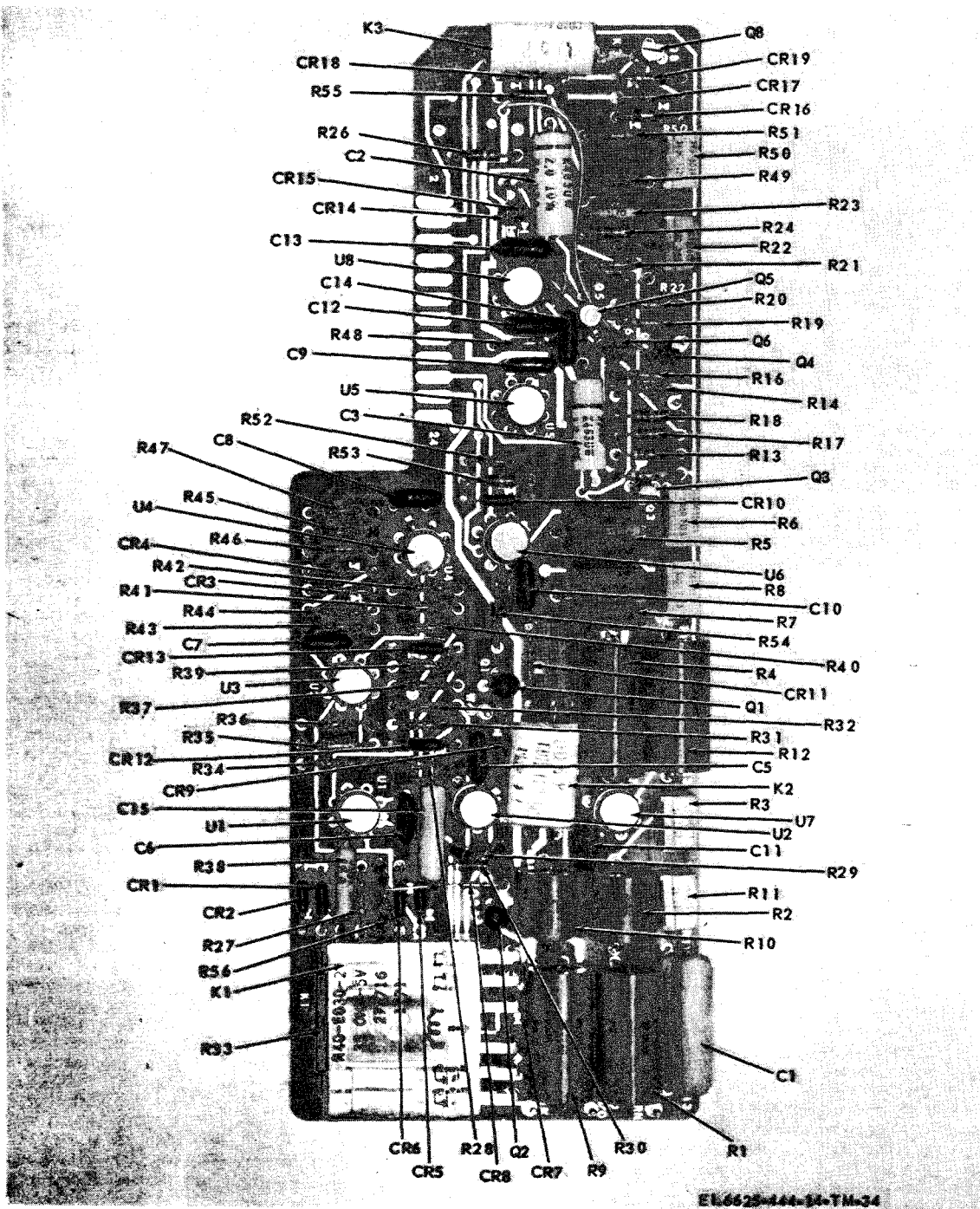
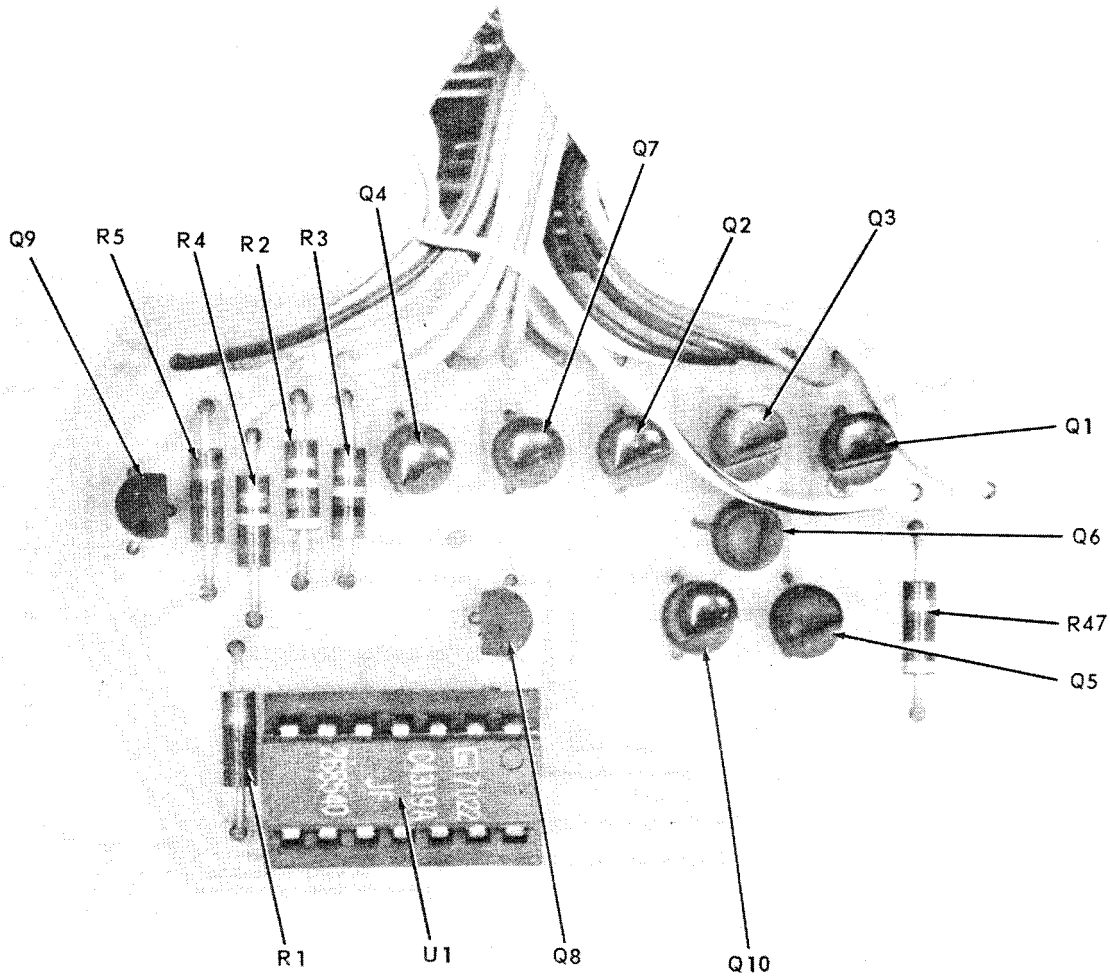
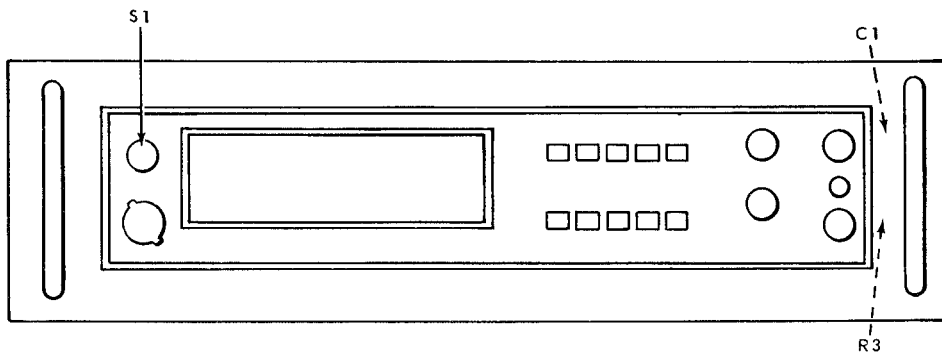

Figure 6-10. Ratio input (A3) component parts.



EL6625-444-14-TM-35

Figure 6-11. Decimal logic (A18) component parts.



EL6625-444-14-TM-36

Figure 6-12. Front panel (A16) component parts.

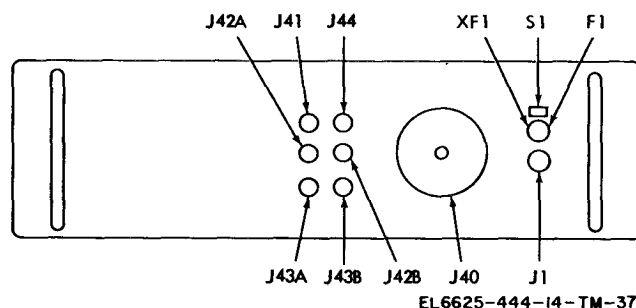

Figure 6-13. Rear panel (A17) component parts.

Section II. TOOLS, TEST EQUIPMENT AND TROUBLESHOOTING

6-5. Tools and Test Equipment Required

This section contains a listing (table 6-7) of test

equipment required for maintenance of the voltmeter. No special tools are required.

Table 6-7. Required Test Equipment

Test equipment	Common name	NSN	Reference paragraph
Differential Voltmeter AN/USM-98	Differential voltmeter	6625-00-753-2115	6-7
Oscilloscope AN/USM-281A	Oscilloscope	6625-00-228-2201	6-7
Meter Test Set TS-682/GSM-1	Ac voltage calibrator	6625-00-669-0747	6-8
John Fluke Model 332A9	Dc voltage calibrator	6625-00-239-8924	6-7
	Resistor, 1M ± 5% ¼W		6-17d
	Capacitor, 0.22 µF, 100V (Polystyrene)		6-17d

6-6. Troubleshooting Instructions

a. The troubleshooting information contained in this section includes both step-by-step procedures and fault logic diagrams to assist in rapidly locating a defective assembly and component parts.

b. Troubleshooting starts by first performing a thorough visual inspection for improperly seated plug-in assemblies, loose or broken wires, physically damaged parts, and other obvious problems. Next, the performance characteristics should be checked in accordance with paragraph 6-16 and any discrepancies noted. The results from these tests can then be used to help in locating the exact source of trouble.

6-7. Section Fault Isolation

a. General. The voltmeter consists of four major sections: power supply; analog; digital; and ratio. Each section, except for the power supply, consists of a number of subassemblies which together perform a separate but distinct

task. Since a number of subassemblies are involved, the first step in troubleshooting after visual inspection is to isolate the trouble to a particular section. Once this is accomplished, each subassembly in that particular section can then be tested to reveal the exact source of trouble.

NOTE

Install each assembly referenced during troubleshooting on the extender card provided with the voltmeter to facilitate access to test points.

b. Power Supply. Correct operation of the power supply section (A 1) is verified by making the voltage checks in table 6-8. All circuitry for this section is contained on the power supply assembly the location of which is shown in figure 6-1. Test point and adjustment locations are shown in figure 6-2. Component parts are shown in figure 6-9.

Table 6-8. Power Supply (A1) Checks

	Test point (A1TP4 common)	Voltage (VDC)	Adjustment
TP2		+18 ± 10 mV	R11
TP3		-18 ± 375 mV	None
TP5		+5V ± 150 mV	Remove R17 to increase
TP1		+200 ± 5V	None

c. *Analog Section.* The circuitry comprising this section is contained in both the buffer (A11) and active filter (A10) assemblies. Test point locations are shown in figure 6-1. To determine if a trouble exists in the analog section, proceed as follows:

(1) Connect a battery powered differential voltmeter to A10TP4 (-) and TP3 (+).

(2) Select the 10 volt range and VDC function on the voltmeter.

(3) Turn on the voltmeter and then apply a +10V DC input to its INPUT terminals.

(4) Verify that the differential voltmeter indicates -10V DC is present at A10TP4 and TP3.

(5) Apply full-scale input voltages on selected ranges of 1,100, and 1,000 volts. Each range shall produce the same voltage specified in step (4).

NOTE

For inputs of less than full-scale on any range, the voltmeter will produce a proportionally less voltage at A10TP4 and TP3. For example, a +10V DC input in the 100-volt range will produce -1V DC.

(6) If the voltage at A10TP4, and TP3 is not correct, the trouble is in the analog section which consists of the buffer and active filter assemblies. Applicable troubleshooting procedures for each of these assemblies are contained in paragraph 6-8. If the voltage at A10TP4 and TP3 is correct, the problem lies in the digital section. Troubleshooting procedures for the digital section are contained in *d* below.

NOTE

Remove the ratio input (A3) when troubleshooting the digital section.

d. *Digital Section.* The digital section circuitry is contained in the A-to-D converter (fig. 6-5)

logic (fig. 6-6), and display (fig. 6-7). The test point locations are shown in figure 6-1. Since each assembly performs a number of separate functions, they are divided into the independent subsections shown in table 6-9 for troubleshooting. Troubleshooting of the digital section is performed in the sequence shown in figures 6-14 and 6-15. Waveforms of commands and signals referenced in figures 6-14 and 6-15 are contained in figures 6-16 through 6-22. Included with each waveform is the applicable test point and timing relation to other waveforms. All waveforms were taken with the voltmeter placed in the continuous measurement mode.

NOTE

The storage cycle can be by passed if there is a suspicion that it is faulty (usually indicated by flashing digits) by jumpering A1TP5 (+5V) to A14TP2. If the readout is then observed to be correct, the storage cycle circuitry is faulty. If not, the trouble lies elsewhere.

Table 6-9. Digital Section Subsections

Assembly	Subsection
A-to-D Converter (A9)	A-to-D Amplifier Sample and Hold Analog Comparator Ladder (Primary and Secondary) Display Storage
	Master Clock CCO Analog Cycle Control Display Storage Control 6-State Shift Register 16-State Binary Counter
Display (A14)	Range Counter Sample Command Oscillator Readout Tubes and Controls

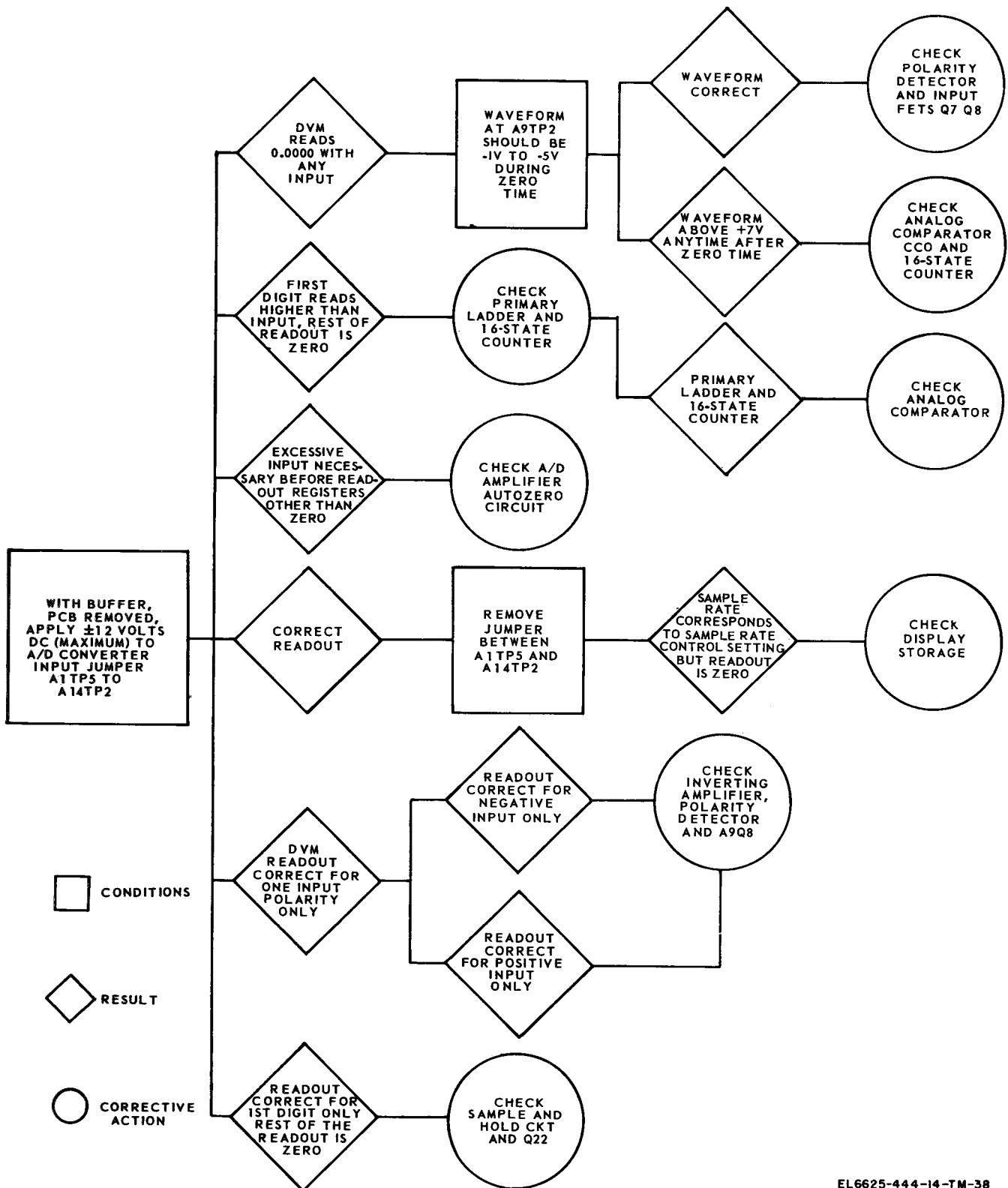

EL6625-444-14-TM-38

Figure 6-14. A-to-D converter and logic troubleshooting.

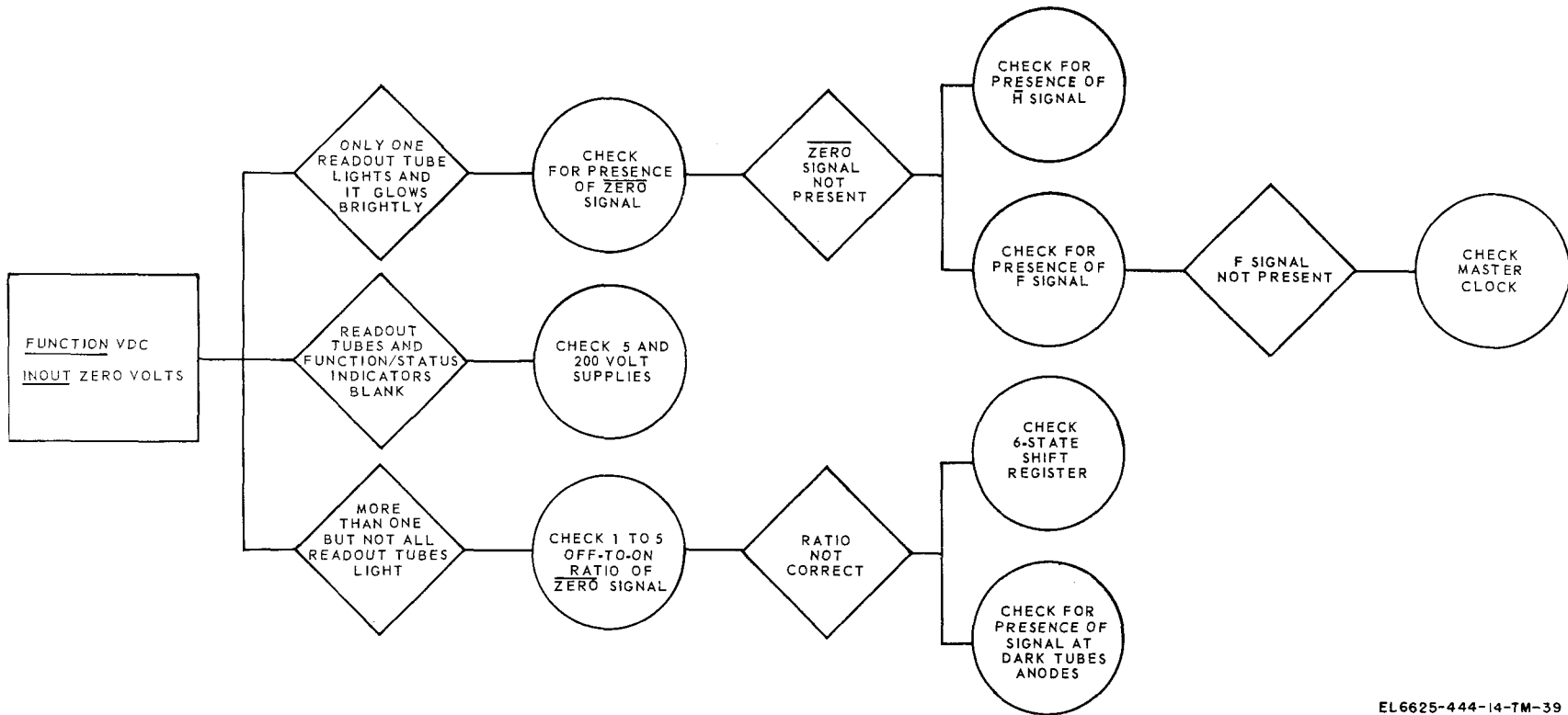

EL6625-444-14-TM-39

Figure 6-15. Display troubleshooting.

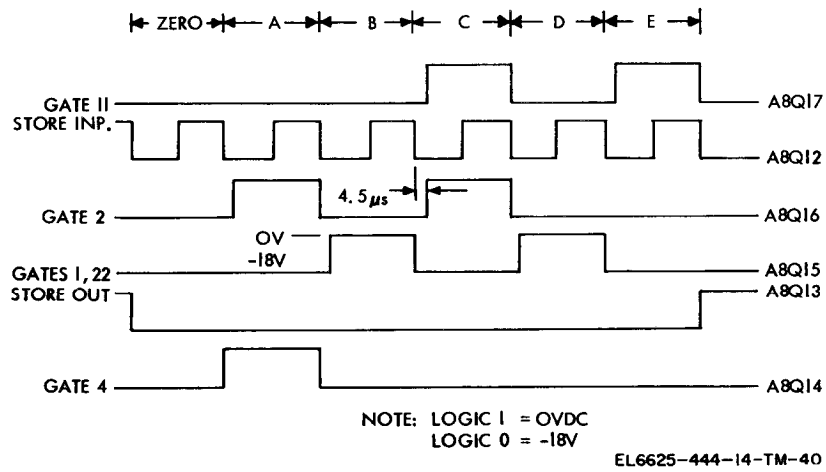

Figure 6-16. A-to-D converter waveforms.

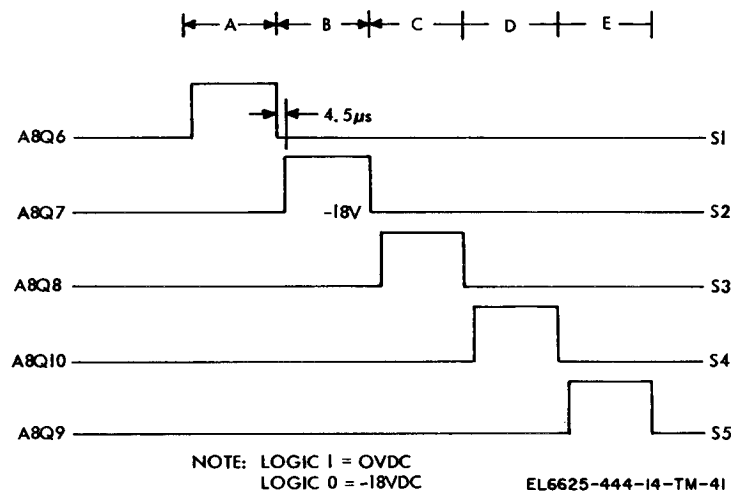

Figure 6-17. Analog storage waveforms.

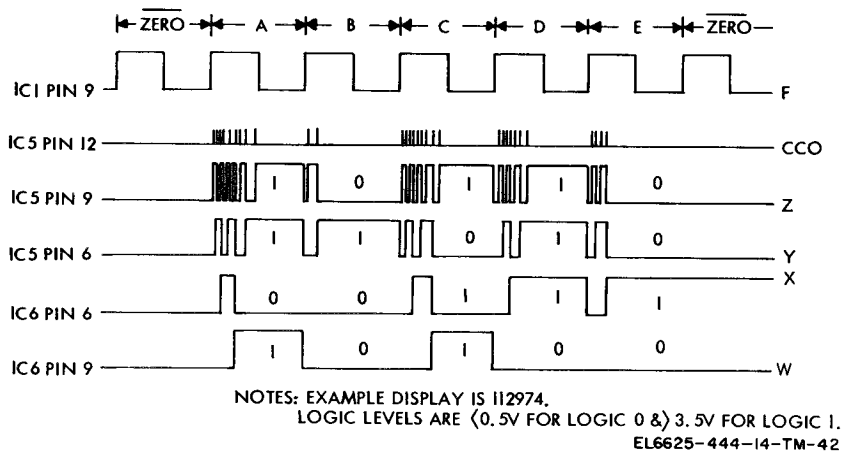

Figure 6-18. 16-State binary counter waveforms.

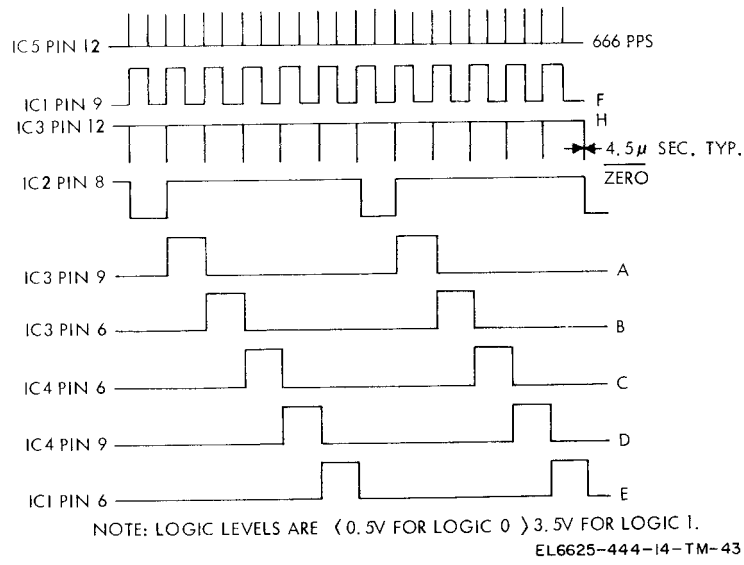

Figure 6-19. 6-State shift register waveforms.

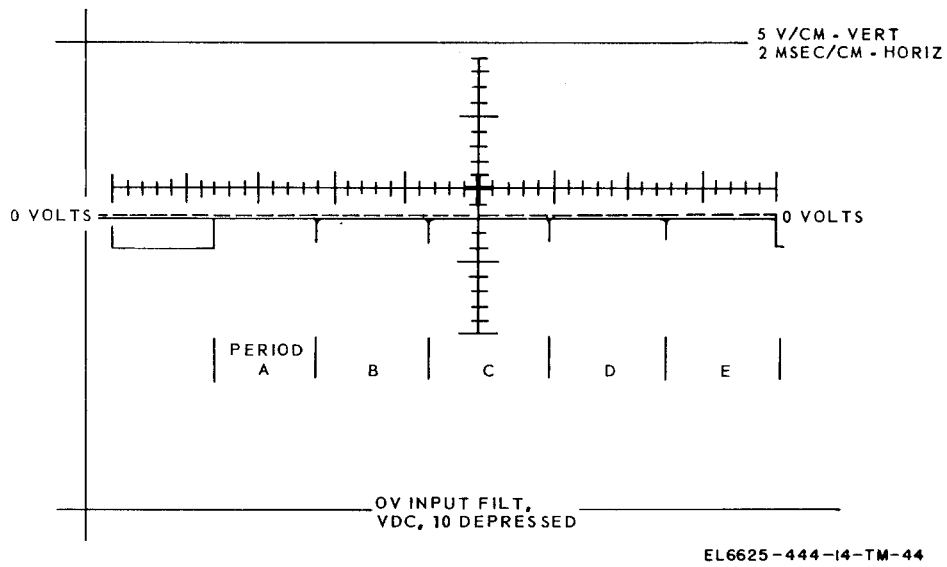
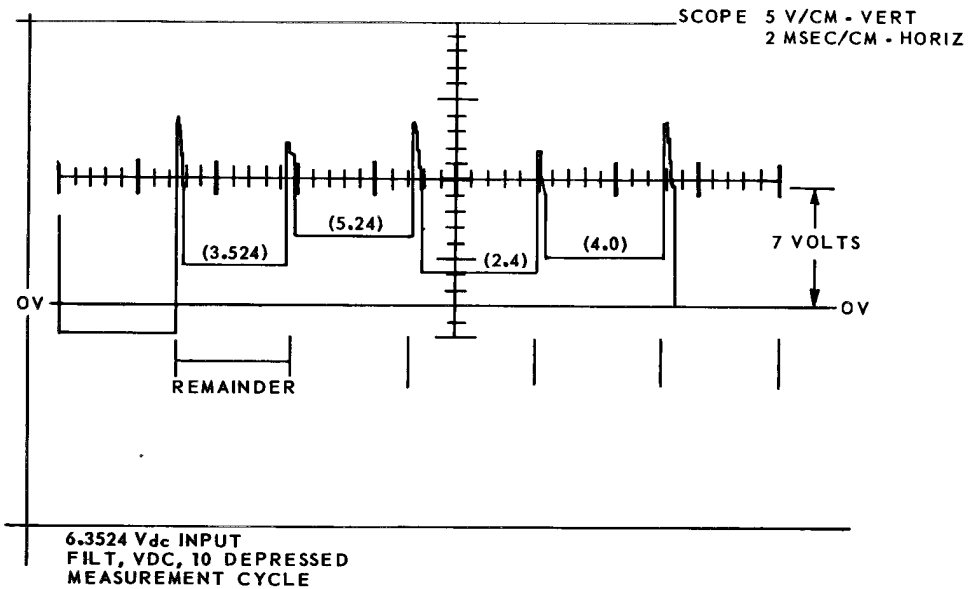

Figure 6-20. A9TP2 zero input.



- NOTES: 1. NOTICE THE NUMBER OF COUNTS ON EACH PULSE.
2. TIME BETWEEN EACH COUNT SHOULD BE LARGER THAN PRECEEDING TIME.
3. PERIOD E REMAINDER WILL BE UNSTABLE DUE TO AMPLIFIER NOISE.

EL6625-444-14-TM-45

Figure 6-21. A9TP2 6.3524 V input.

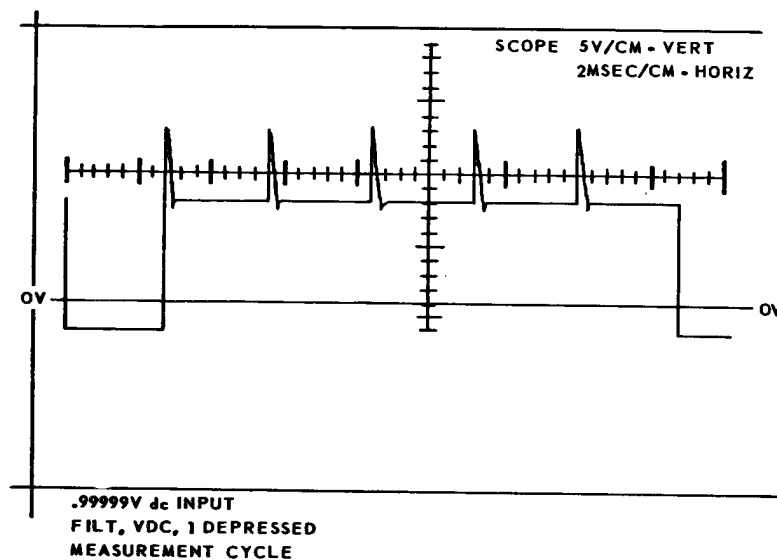

- NOTES:
1. 9 COUNTS ON EACH PULSE.
2. EACH COUNT HAPPENS ON THE SAME LEVEL.
(EX 1ST LEVEL COUNT ON EACH PULSE).

EL6625-444-14-TM-46

Figure 6-22. A9TP2 0.99999V input.

NOTE

If the VDC mode of operation is correct and the RATIO mode is faulty, the trouble lies in the ratio input (A3) assembly.

e. Ratio Section. The ratio section circuitry is located on the ratio input (A3) assembly. Component part locations are shown in figure 6-10. Test point locations are shown in figure 6-1. To determine if a trouble exists in the ratio section, proceed as follows:

(1) Connect a battery powered digital voltmeter to A9TP7 (-) and TP5 (+).

(2) Select AUTO range, VDC, and RATIO functions on the voltmeter.

(3) Apply a -10.0V DC input to the EXT REF terminals on the rear panel.

(4) Connect a shorting jumper between the INPUT terminals on the front or rear panel.

(5) Turn on the voltmeter and verify that the differential voltmeter indicates -7.0V DC is present at A9TP7 and TP5. If the voltage is other than -7.0V DC, the trouble lies in difference amplifier and /or buffer amplifier circuitry.

(6) Apply a +10.0V DC input to the EXT REF terminals on the rear panel. This is easily accomplished by reversing the input leads to these terminals.

(7) Verify that the differential voltmeter indicates +7.0V DC is present at A9TP7 and TP5. If not, the polarity detector circuitry is defective.

(8) Remove the shorting jumper from the INPUT terminals and select the 100V range.

(9) Apply a -10.5V DC input to both EXT REF and INPUT terminals.

(10) Verify digital readout indicates 100.00%.

(11) Increase inputs to -10.6V DC, observing digital readout indicates 100.000 % \pm 50 digits. If not, the trouble lies in the range detector circuitry.

6-8. Analog Section Troubleshooting

a. General. Troubleshooting of the buffer (A11) and active filter (A10) are contained in *b* and *c* below. Prior to troubleshooting either of these assemblies, insure that the trouble is located in the analog section, paragraph 6-7 *c*. Component part locations are shown in figures 6-3 and 6-4. Test point locations are shown in figure 6-1.

b. Buffer Checks. Troubleshooting of the buffer (A11) assembly is accomplished as follows:

(1) Select the VDC, FILT, and 10V range, Also rotate the SAMPLE RATE control fully clockwise.

(2) Turn on the voltmeter and apply +30V DC to the INPUT terminals.

(3) Verify that the digital readout is +11.9999.

(4) Apply -30 VDC to the INPUT terminals, observing that the digital readout is -11.9999. If the readout in this step or step (3) does not correspond, the most probable fault is in the overload circuitry; however, a secondary cause could be circuitry associated with the amplifier.

(5) Disconnect the voltage applied to the INPUT terminals.

(6) Connect a shorting jumper between the INPUT terminals.

(7) Rotate the DC ZERO control throughout its range. The digital readout shall change plus 3 or 4 digits in the fully clockwise position and minus 3 or 4 digits in the fully counterclockwise position.

(8) Connect a battery powered differential voltmeter to A10TP4 (-) and TP3 (+).

(9) Rotate DC ZERO control to obtain 0 ± 10 mV at A10TP3 and TP4. If the voltage at A10TP3 and TP4 or the digital readout will not swing through zero, adjustment of A11R28 (COARSE DC ZERO) is necessary; however, the amplifier circuitry is more than likely defective.

(10) Disconnect the shorting jumper from the INPUT terminals.

(11) Connect the differential voltmeter to the HI INPUT terminal (+) and A11TP2 (-).

(12) Apply -12.5V DC to the INPUT terminals. The digital readout shall be -11.9999; record the differential voltmeter indication.

(13) Apply +12.5V DC to the INPUT terminals, observing that the digital readout is +11.9999 and that the differential voltmeter indication is with $\pm 25 \mu\text{V}$ of the value recorded in step (12). If the preceding checks are as specified, the fault lies in the active filter (A10) assembly. If not, the amplifier gain circuitry in the buffer assembly is defective.

NOTE

Replacement of A11Q5, U1, R24 or R27 in the buffer assembly requires selection of R22 and R25 in accordance with paragraph 6-14.

c. Active Filter Checks. Troubleshooting of the active filter (A10) assembly is accomplished as follows:

(1) Select the REMOTE mode of operation and connect a battery powered differential voltmeter to A10TP5 (-) and TP3 (+).

(2) Disconnect voltage applied to INPUT terminals and record the voltage at A10TP5 and TP3.

(3) Apply +10V DC to A10TP4 (-) and TP5 (+). The voltage at A10TP5 and TP3 shall not change more than $\pm 100 \mu\text{V}$.

(4) Apply -10V DC to A10TP4 (-) and TP5 (+), observing that the voltage at A10AP5 and TP3 does not change more than $\pm 100 \mu\text{V}$. If the preceding are as specified, the active filter is operational. If not, the gain control circuitry is faulty.

(5) Disconnect equipment from the voltmeter

and select VDC and FILT mode. Insure 10V range is selected.

(6) Apply a 3V rms $\pm 1\%$, 60 Hz signal to the INPUT terminals.

(7) Rotate SAMPLE RATE control to obtain a digital readout change of approximately two times a second. The digital readout shall be less than +20 digits. If not, the filter circuitry is defective.

Section III. MAINTENANCE OF THE VOLTMETER

6-9. General

This section contains maintenance instructions for the voltmeter. The information is arranged under paragraphs covering disassembly, cleaning, repair and replacement, assembly, and component selection. Contents of these paragraphs provide complete maintenance instructions for the voltmeter. The performance tests in paragraph 6-16 shall be conducted after any repairs are made.

6-10. Disassembly

a. Covers. Removal of dust covers and inner guard covers is accomplished as follows:

(1) Remove top dust cover by unlocking fasteners.

(2) Remove top guard cover by removing four attaching screws.

(3) Remove bottom dust cover by unlocking fasteners.

(4) Remove bottom guard covers by removing single attaching screw from rear-most cover and four screws from front bottom cover.

b. Panels and Chassis. Disassembly of the panels and chassis is done in the sequence shown in figures 6-23 and 6-24 together with the following procedure. Referenced letters correspond with those shown in figures 6-23 and 6-24.

(1) Remove each control knob (A, fig. 6-23) on the front panel by loosening setscrews.

(2) Remove seal nuts (A) associated with each control shaft.

(3) Tag, unsolder, and disconnect wire from GUARD terminal (B) at terminal riveted to chassis.

(4) Tag and unplug wiring (C) to INPUT terminals.

(5) Remove the front panel (D) by first removing 12 attaching screws. Next, carefully pull front panel free of pushbutton switches while at the same time removing the boots from the

switches. Retain gaskets freed upon removal of front panel.

(6) Unplug and remove printed circuit boards (E), except for the printer output (A7) which is attached to the rear panel by its cabling.

(7) Cut cable ties (F) at rear panel INPUT harness, inner chassis transformer secondary harness, and inner chassis power harness (two places).

(8) Disconnect transformer harness at TB2 (G) and pull harness out and away from chassis.

(9) Tag and disconnect rear INPUT terminal wiring (H). Wiring is disconnected by removing nuts on each terminal.

(10) Tag, unsolder, and disconnect rear panel GUARD wire (I) at inner chassis.

(11) Remove 12 screws (J) which attach inner chassis to main chassis.

(12) Pull EXT REF input cabling (K) toward the front of the voltmeter until free of the inner chassis.

(13) Slide the inner chassis (L) forward while at the same time lifting its rear section up. Make sure the cable clamp and cabling on the right, rear section stays on the side near the rear of the voltmeter.

(14) Remove the inner chassis by first pulling the inner chassis up and towards the rear of the voltmeter. Next, apply a slight upward pressure on the front section (M) just before the RANGE and SAMPLE RATE controls bottom out against the chassis and then remove the inner chassis. Position inner chassis as shown in figure 6-23.

(15) Straighten locking tabs on the DC ZERO and RATIO FULL SCALE potentiometers (N, fig. 6-24) and then push them free of panel.

(16) Remove inner front panel by removing seven screws (O).

(17) Remove four screws (P) which secure the rear of the display assembly (A14).

(18) Lower the display assembly (A14) just enough to remove four mounting screws (Q) on

the decimal logic (A18) and then remove the display assembly (A14).

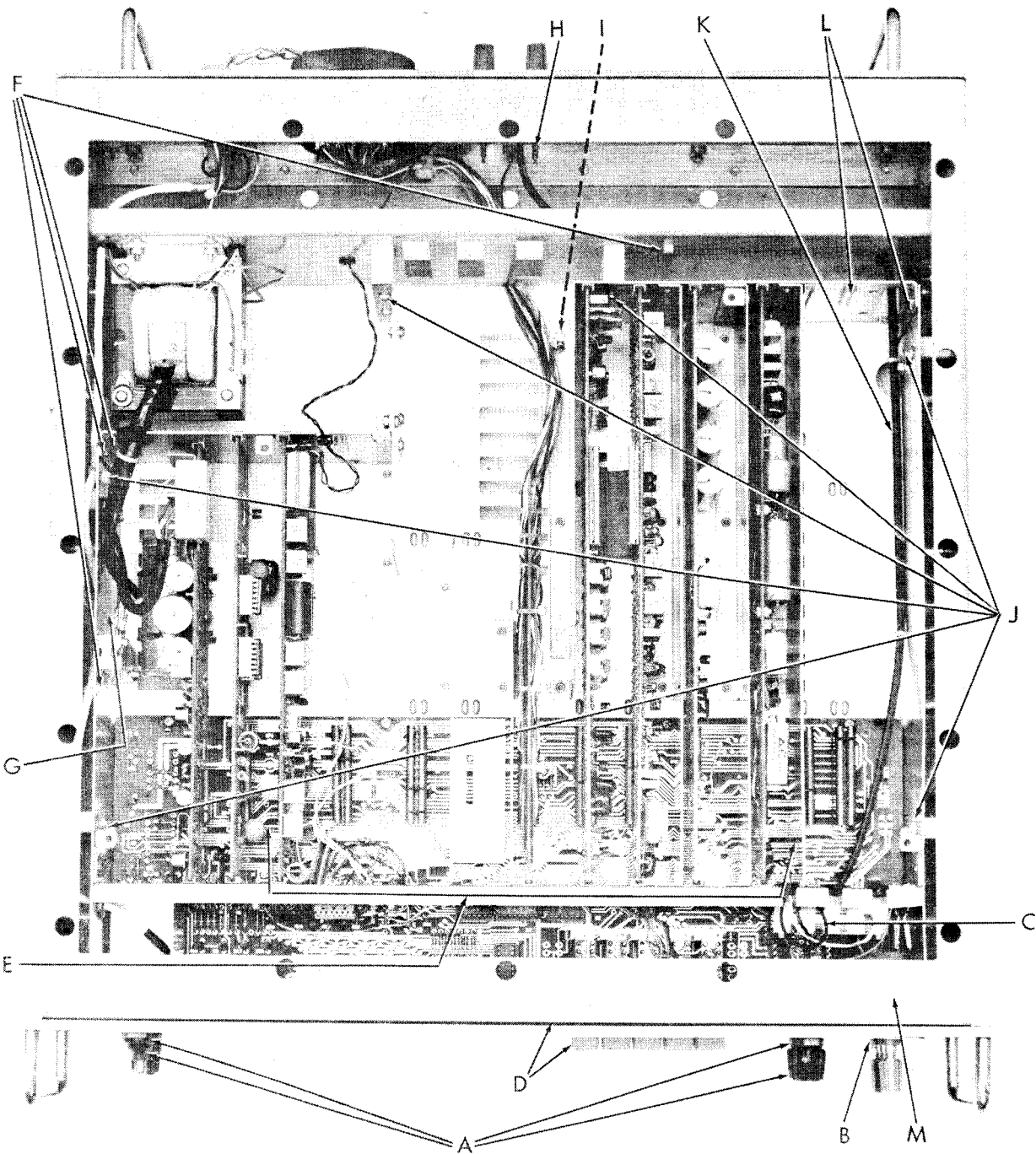

EL 6625-444-14-TM-47

Figure 6-23. Disassembly sequence (A through M).

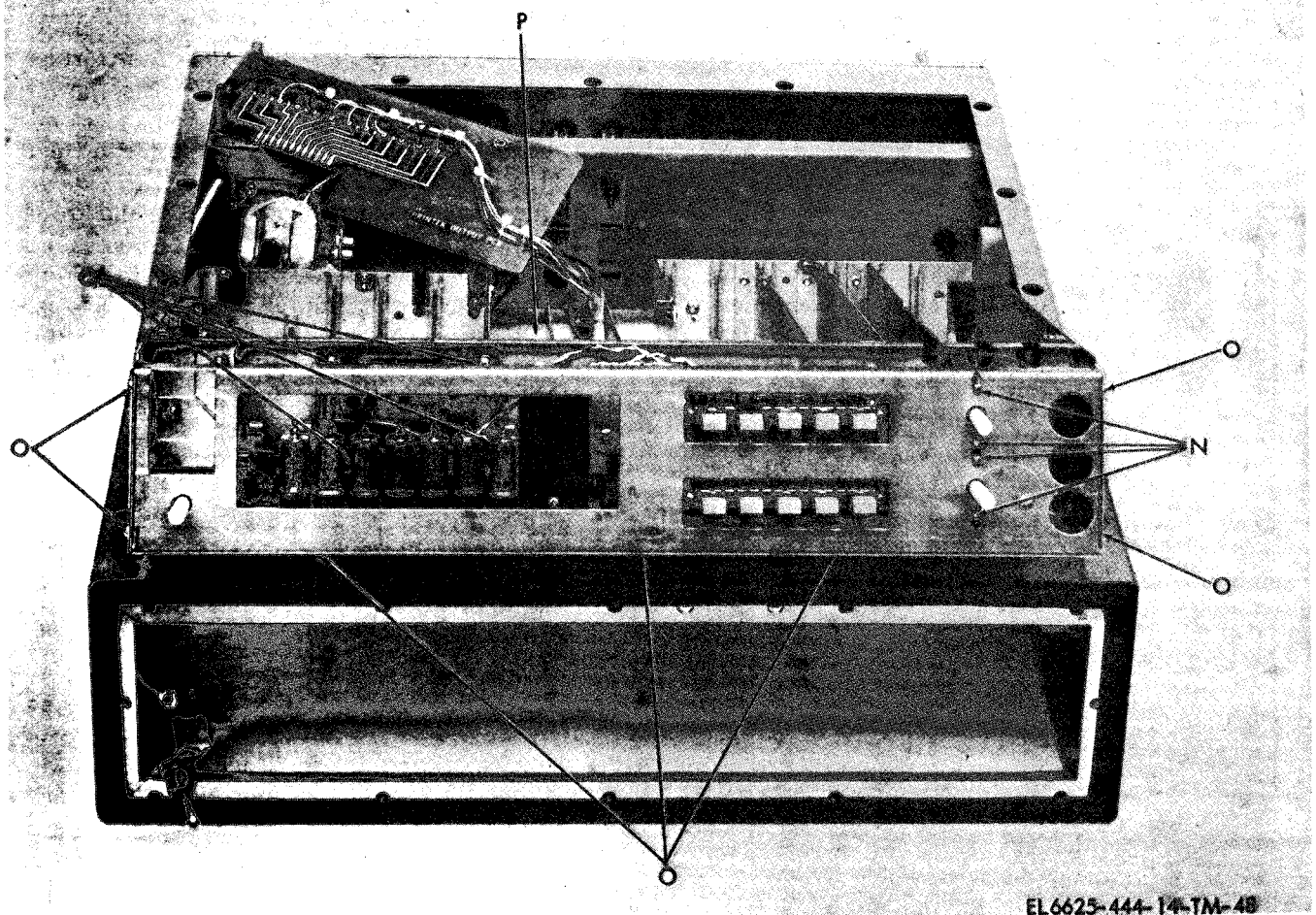

Figure 6-24. Disassembly sequence (n through u).

6-11. Cleaning

For cleaning instructions, refer to paragraph 4-9.

6-12. Repair and Replacement

NOTE

Soldering operations shall be accomplished in accordance with MIL-STD - 454. A vacuum operated resoldering tool shall also be used whenever resoldering is required. Maximum allowable soldering iron wattage rating is 25 watts.

a. Function Display. Repair of the function display is limited to replacement of lamps using the following procedure.

(1) Remove the top and bottom dust covers and inner guard covers in accordance with paragraph 6-10a.

(2) Remove the function display located adjacent to the readout tubes near the front panel by removing its attaching screws. These screws are accessible from the bottom of the voltmeter.

(3) Remove the plexiglass cover from the function display by removing attaching screws.

(4) Remove and replace the defective lamp or lamps using standard soldering practices.

(5) Install the plexiglass cover and attach using the screws removed in step (3).

(6) Install the function display in the voltmeter and attach using the screws removed in step (2).

b. Readout Tubes. Repair of the readout tubes is limited to replacement. Proceed as follows:

(1) Remove the top and bottom dust covers and inner guard covers in accordance with paragraph 6-10a.

(2) Remove and replace readout tubes V1 through V7 using standard soldering practices.

c. Pushbutton Switches. Repair of the pushbutton switches is limited to replacement. Proceed as follows:

(1) Remove the top and bottom dust covers

and inner guard covers in accordance with paragraph 6-10a.

(2) Disassemble the voltmeter in accordance with paragraph 6-10 *b*.

(3) Tag, unsolder, and disconnect wiring between switch assembly and display assembly (A14).

(4) Unsolder lower range switch terminals at display assembly. Insure all solder is removed.

(5) Remove switch assembly from display assembly.

(6) Remove screws from brackets on each switch assembly and separate switch assemblies. Insure metal spacers on function switches are not dislodged during separation and note their exact position.

(7) Replace defective switch assembly and attach both assemblies to brackets using screws removed in step (6). Insure metal spacers are correctly installed as noted in step (6).

(8) Position switch assembly on display assembly (A14) and attach by soldering lower range switch terminals.

6-13. Assembly

a. Chassis and Panels. Assembly of the chassis and panels is essentially in reverse order of disassembly (fig. 6-23 and 6-24). Certain steps, however, are peculiar only to assembly. To assemble the chassis and panels, proceed as follows:

(1) Install the display assembly (A14) and attach near the rear panel using four screws (P, fig. 6-24).

(2) Attach the decimal logic (A18) to the display assembly (A14) using four screws (Q).

(3) Install the inner front panel, taking care in guiding the DC ZERO and RATIO FULL SCALE shafts through their respective holes, using seven screws (O).

(4) Twist each locking tab on the DC ZERO and RATIO FULL SCALE potentiometers (N) to lock them in place.

(5) Carefully install the inner chassis by tilting the front section down and sliding into position in the voltmeter. Lower its rear section while guiding the cable and clamp on the right, rear section clear.

(6) Insert the EXT REF input cable (K, fig. 6-23) through the grommet at the rear of the inner chassis and attach each wire to the appropriate INPUT terminal (H) on the rear panel.

(7) Connect, solder, and remove tag from GUARD wire (I).

(8) Install 12 screws (J) which attach inner chassis to main chassis.

(9) Connect transformer harness to TB2 (Q).

(10) Replace cable ties (F) at rear panel INPUT harness, inner chassis transformer secondary harness, and inner chassis power harness (two places).

(11) Install printed circuit boards (3) in their respective positions (fig. 6-1).

(12) Install gaskets, switch boots, and front panel (D) using 12 screws.

(13) Connect, solder, and remove tag from GUARD wire (B) at terminal riveted to chassis.

(14) Connect INPUT terminal wiring (C) and remove tags.

(15) Install seal nuts (A) at each control shaft.

(16) Install control knobs (A) and tighten setscrews.

b. Covers. Installation of covers is accomplished as follows:

(1) Install rear most bottom guard cover using single attaching screw.

(2) Install front, bottom guard cover using four screws.

(3) Install bottom dust covers and lock each fastener.

(4) Install top guard cover using four screws.

(5) Install top dust cover and lock each fastener.

6-14. Component Selection

The buffer (A11) assembly contains two selected resistors, R22 and R25. The value of these resistors must be selected whenever Q5, R24 and R27 or U1 are replaced. Selection procedure is as follows:

NOTE

Refer to figure 6-3 for location of component parts on the buffer assembly.

a. Remove the buffer assembly (A11) and connect shorting jumpers across R22, R25, and R28 (COARSE DC ZERO).

b. Install the buffer assembly in the voltmeter and then connect a shorting jumper between the INPUT terminals.

c. Turn on the voltmeter and select VDC, FILT, and 10V range.

d. Observe the digital readout on the voltmeter and select a type RN60XXXXF resistor for either R22 (negative readout) or R25 (positive readout) using the information in table 6-10.

Table 6-10. Buffer (A11) Resistor Values

Digital readout	Resistor value *
0.0000 to 0.0001	None
0.0001 to 0.0002	6.980K
0.0002 to 0.0004	2.100K
0.0004 to 0.0006	35.70K
0.0006 to 0.0008	51.10K
0.0008 to 0.0010	64.90K
0.0010 to 0.0012	80.60K
0.0012 to 0.0014	95.30K
0.0014 to 0.0016	110.0K
0.0016 to 0.0018	124.0K
0.0018 to 0.0020	140.0K
0.0020 to 0.0022	154.0K
0.0022 to 0.0024	169.0K
0.0024 to 0.0026	187.0K
0.0026 to 0.0028	200.0K
0.0028 to 0.0030	215.0K
0.0030 to 0.0032	232.0K
0.0032 to 0.0034	249.0K
0.0034 to 0.0036	267.0K
0.0036 to 0.0038	280.0K
0.0038 to 0.0040	301.0K
0.0040 to 0.0042	316.0K
0.0042 to 0.0044	332.0K
0.0044 to 0.0046	348.0K
0.0046 to 0.0048	365.0K
0.0048 to 0.0050	383.0K

*RN60XXXXF type resistors

e. Turn off the voltmeter and remove the buffer assembly (A11).

f. Install the resistor selected in accordance with step das R22 or R25 in the buffer assembly (A11).

g. Solder a jumper across the unused resistor position of R22 or R25.

h. Disconnect the shorting jumper across R28.

i. Install the buffer assembly (A11) in the voltmeter.

j. Turn the voltmeter on. Insure that the VDC, FILT, and 10V range are selected.

k. Adjust A11R28 (COARSE DC ZERO) for a digital readout of 0.0000.

l. Disconnect the shorting jumper from the INPUT terminals.

NOTE

The voltmeter requires total recalibration in accordance with paragraph 6-16 after selection of R22 or R25.

Section IV. TESTING PROCEDURES

6-15. General

a. This section contains performance testing and alignment procedures for the voltmeter. Performance testing shall be conducted prior to performing any maintenance or alignment. Alignment of the voltmeter is required after any maintenance affecting alignment accuracy is performed or if unsatisfactory results are obtained from performance testing. Alignment, however, should only be attempted if the volt meter is out of alignment but is fully operational

b. All testing shall be conducted in a clean draft free environment having an ambient temperature of 730 ± 90 F. and a relative humidity of less than 70%. Required test equipment is listed in table 6-7.

6-16. Performance Testing

a. *Preliminary Operation.* Connect the volt-

meter to ac line power and set the controls as follows:

- POWER.....ON
- FUNCTION.....VDC, FILT
- RANGE.....10
- SAMPLE RATE..... Full cw
- DC ZERO..... Midrange
- RATIO FULL SCALE Midrange

b. *DC Volts Accuracy Checks.*

(1) Connect a shorting jumper between the INPUT terminals.

(2) Adjust the front panel DC ZERO control for a digital readout of 00.0000 ± .0001.

(3) Connect a dc voltage calibrator to the INPUT terminals, observing polarity.

(4) Apply each of the input voltages shown in table 6-11 to the INPUT terminals. The digital readout shall be as specified.

Table 6-11. Voltmeter Accuracy Checks

Input (Volts DC)	Voltmeter	
	Range	Accuracy
+1.0000	10	± .010
10.0000	10	
10.0000	100	± .10
100.000	100	
100.000	1000	+0099.99 to 0100.01
1000.00	1000	
1000.00	1000	+999.90 to 1000.10

(5) Repeat step (4) with negative input voltages. The readout must be the same as for positive inputs, except that the polarity indication will be negative (-).

(6) Apply zero volts to the INPUT terminals and depress the AUTO RANGE switch. The digital readout shall be 00.0000 ± .0001.

(7) Apply +1000.00 volts dc to the INPUT terminals. The voltmeter shall range automatically and the digital readout shall be +1000.00 ± .10.

c. *Ratio Accuracy Checks.* Connect equipment as shown in figure 6-25 and set the controls as follows:

FUNCTION	VDC, FILT, RATIO
RANGE	10
SAMPLE RATE	Full CW
RATIO FULL SCALE	Midposition

(1) Set dc voltage calibrator output to 5.0000V, observing digital readout is +100.000% ± 0.050.

(2) Rotate RATIO FULL SCALE control for a digital readout of +100.000 ± .001.

(3) Disconnect dc voltage calibrator from the INPUT terminals and then connect a shorting jumper between the INPUT terminals.

(4) Verify that the digital readout is 00.0000%. The last digit may flash producing a digital readout of 00.0000/1.

(5) Reconnect the dc voltage calibrator to the INPUT terminals, except reverse polarity.

(6) Verify that the digital readout is +100.000% ± 0.001. Adjust RATIO FULL SCALE control, if required, to obtain required readout.

NOTE

Ratio of two negative signals is positive.

(7) Connect equipment as shown in figure 6-25.

(8) Set dc voltage calibrator output to 50.000V, observing that the digital readout is +11.9999%..

(9) Select 100V range, observing that the digital readout is 100.00% ± 0.001. Adjust

RATIO FULL SCALE control, if required, to obtain required readout.

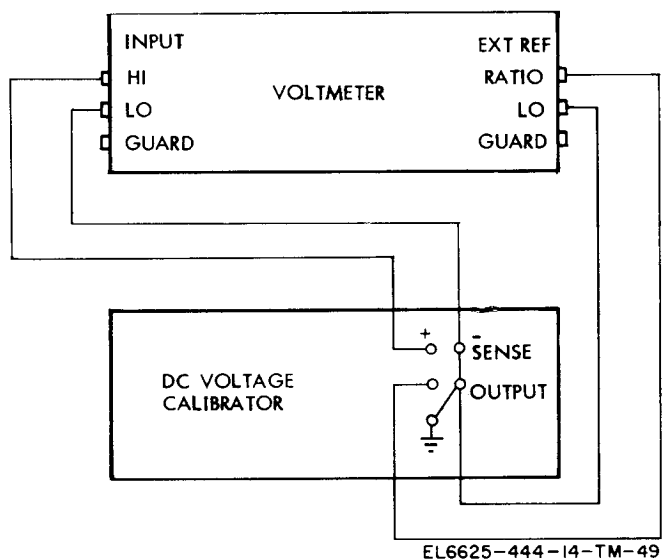

Figure 6-25. Ratio check equipment connections.

6-17. Alignment

a. *General.* The voltmeter shall be aligned every six months or whenever repairs have been made to its internal circuitry. Adjustment and test point locations are shown in figure 6-2. They are also labeled on the top guard cover. Alignment should only be attempted after completing the performance tests in paragraph 6-16. Results of the performance tests can be used to determine if the voltmeter is operational and only requires minor adjustment (alignment) or that repair (troubleshooting) is necessary.

b. *Equipment Setup.* Prior to voltmeter alignment, perform the following setup procedure:

(1) Unlock the top dust cover fasteners. Leave the dust cover in place.

(2) Set the 115/230 switch on the rear panel to the 115 position.

(3) Connect the voltmeter power cord to a 115 VAC powerline.

(4) Turn on the voltmeter and allow 30 minutes for equipment warm up.

NOTE

Unless otherwise specified, verify the results of each test and take corrective action whenever the test requirement is not met before proceeding.

c. *Buffer Zero Adjustment.* Perform buffer zero adjustment as follows:

(1) Select the VDC and FILT functions on the voltmeter.

(2) Connect a shorting jumper between the HI and LO INPUT terminals.

(3) Remove the top dust cover and the guard cover.

CAUTION

If the differential voltmeter is not battery-operated, connect to the powerline by means of an isolation transformer to provide ac isolation between the units.

(4) Connect a differential voltmeter between A10TP4 (LO) and A10TP3 (HI).

(5) Adjust the front panel ZERO control on the voltmeter for a reading of $\pm 10 \mu\text{v}$ on the differential voltmeter.

d. *Bias Current Adjustment.* Perform bias current adjustment as follows:

(1) Remove the shorting jumper from between the HI and LO INPUT terminals and replace with a one-megohm 5% resistor connected in parallel with a $0.22 \mu\text{f}$ capacitor (table 6-7).

(2) Adjust the BIAS ADJ control (A11R17) located on the buffer assembly (All) to obtain a reading between $\pm 10 \mu\text{v}$ on the differential voltmeter.

(3) Repeat steps (2), (3), and (4) of the preceding Buffer Zero Adjustment, and repeat step (2) of this Bias Current Adjustment until readings of $\pm 10 \mu\text{v}$ (or better) are obtained on the differential voltmeter.

e. *Reference Voltage Adjustment.* Perform reference voltage adjustment as follows:

(1) Connect the differential voltmeter to the LO SENSE (A9TP7) and the HI SENSE (A9TP5).

(2) Connect a shorting jumper between the HI and LO INPUT terminals.

(3) Adjust the REF adjustment (8R57) to obtain a reading between 6.999975 and 7.000025 on the differential voltmeter.

f. *A-to-D Zero Adjustment.* Perform the A-to-D zero adjustment as follows:

(1) Remove the shorting jumper from the

INPUT terminals and connect the test equipment as shown in figure 6-26.

(2) On the differential voltmeter, set the range to one volt, the readout to .550000, and the null sense to 0.1.

(3) On the voltmeter, select the VDC and FILT functions, select the 10 range, and turn the SAM PLE RATE fully clockwise.

(4) Set the dc voltage calibrator to an output of 0.0052 VDC.

(5) Adjust the A-to-D ZERO adjustment (A9R37) to obtain a digital display of +0.0005 on the voltmeter, and a null on the differential voltmeter.

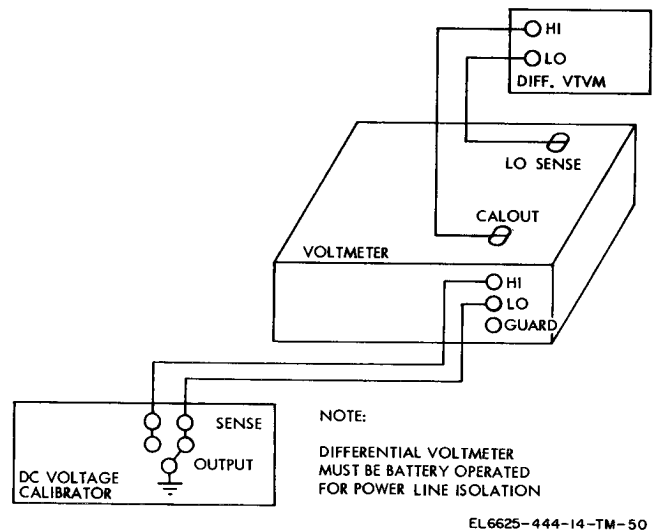

Figure 6-26. Alignment equipment connections.

g. *Positive Alignment Adjustment.* Perform the positive alignment adjustment as follows:

(1) Connect the equipment as shown in figure 6-26.

(2) On the differential voltmeter, set the range to one volt, the readout to .550000, and the null sense to 0.1.

(3) Turn the COMPARATOR LEVEL adjustment (A9R61) to the fully clockwise position.

(4) Set the dc voltage calibrator output +8.00052 VDC.

(5) Adjust the +CAL adjustment (A9R17) to obtain a digital readout of +8.0005 on the voltmeter display, and a null on the differential voltmeter.

h. *Ladder Calibration.* Perform ladder calibration as follows:

(1) Connect the equipment as shown in figure 6-26.

(2) Using the dc voltage calibrator, apply

the input voltages listed in table 6-12 and perform the associated adjustments to obtain the digital

readouts listed in the table for the voltmeter and the differential voltmeter.

Table 6-12. Ladder Alignment

Ladder No.	DC voltage calibrator output	Voltmeter		Diff. v/vm readout
		Adjustment	Readout	
4	+4.000052V	LADDER 4 (A9R45)	+4.0005	NULL
2	+2.000052V	LADDER 2 (A9R48)	+2.0005	NULL
1	+1.00052V	LADDER 1 (A9R50)	+1.0005	NULL

i. Negative Alignment Adjustment. Using the test setup of the preceding Ladder Alignment, perform negative alignment adjustment as follows:

- (1) Set the dc voltage calibrator output to +8.00052 VDC.
- (2) Reverse the polarity of the input voltage to the voltmeter.
- (3) Adjust the -CAL adjustment (A9R14) to obtain a digital readout of -8.0005 on the voltmeter display, and a null on the differential voltmeter.

j. Remainder Adjustment. Using the test setup of the preceding Negative Alignment Adjustment, perform the remainder adjustment as follows:

- (1) On the voltmeter, set the COMPARATOR LEVEL adjustment to the fully counterclockwise position.
- (2) Using the dc voltage calibrator, apply the input voltages listed in table 6-13, and perform the associated adjustment to obtain the readouts listed in the table for the voltmeter and the differential voltmeter.

Table 6-13. Comparator Level Adjustment

Digit No	DC voltage calibrator output	Voltmeter		Diff. v/vm readout
		Adjustment	Readout	
2	+0.900052V	2nd Digit Remainder (A9R58)	+0.9005	NULL
3	+0.99052V	3rd Digit Remainder (A9R56)	+0.9905	NULL
4	+0.99952V	NONE	+0.9995	± 2 Major Divisions

k. Comparator Level Adjustment. Using the test setup of the preceding Remainder Adjustment, perform the comparator level adjustment as follows:

- (1) Disconnect the differential voltmeter from the voltmeter.
- (2) Set the dc voltage calibrator to 0.9995 VDC.
- (3) Adjust the COMPARATOR LEVEL adjustment (A9R61) to obtain a digital display on

the voltmeter which alternates between +0.9999 and +1 .0000.

- (4) Set the dc voltage calibrator output to +1.9999 VDC and then +2.0000 VDC, and note that the voltmeter digital display corresponds.

l. Buffer DC Alignment. Using the test setup of the preceding Comparator Level Adjustment, apply the input voltages listed in table 6-14 and perform the associated adjustments to obtain the readouts listed in the table for the voltmeter.

Table 6-14. Buffer DC Alignment

DC input voltage	Range	Voltmeter	
		Adjustment	Readout
+ 100.000	100	100V (A11R8)	+100.000
+1000.00	1000	1 000V (A11R9)	+1000.00

m. Ratio Alignment. Perform alignment operations as follows:

(1) On the voltmeter, set the FUNCTION switches to VDC and FILT and set the RANGE switch to 10.

(2) Connect a shorting jumper between the INPUT terminals.

(3) If necessary, adjust the front panel DC ZERO control to obtain a readout of 00.0000.

(4) On the voltmeter, set the FUNCTION switches to VDC and RATIO, set the RANGE switch to 10, turn the SAMPLE RATE control fully clockwise, turn the RATIO FULL SCALE control to midposition, and turn the RANGE LEVEL control (A3R50 located through the guard covers) to the fully counterclockwise position.

(5) Connect a shorting jumper between the rear panel INPUT terminals, and connect a jumper between the rear panel EXTERNAL REFERENCE input terminals.

(6) Connect the low terminal of a differential voltmeter to the LO SENSE (A9TP7) test point on the voltmeter, and the high terminal to the HIGH SENSE (A9TP5) test point.

(7) Adjust the ZERO OFFSET control (A3R22) to obtain a reading of - 500 microvolt on the differential voltmeter.

(8) Remove the shorting jumper from the rear panel EXTERNAL REFERENCE input terminals and apply - 10.0000 VDC. (Leave the INPUT terminals shorted.)

(9) Null the differential voltmeter.

(10) Adjust the RATIO FULL SCALE control to fully clockwise and note the reading on the differential voltmeter.

(11) Set the RATIO FULL SCALE control to fully counterclockwise and note the reading on the differential voltmeter.

(12) Set the RATIO FULL SCALE control to obtain a differential voltmeter reading halfway between those noted in steps (10) and (11).

(13) Adjust the 10V CAL control (A3R3) to obtain a reading in the range of +6.999925 and +7.000025 VDC on the differential voltmeter.

(14) Remove the shorting jumper from across the INPUT terminals.

(15) Apply -10.0000 VDC to the INPUT

and EXTERNAL REFERENCE terminals of the voltmeter.

(16) Adjust the 10V COMMON MODE control (A3R11) to obtain a reading of +7.0000 VDC on the differential voltmeter, and a digital readout of 100.0070 ± 2 digits on the voltmeter.

(17) Reduce the input voltage to the INPUT and EXTERNAL REFERENCE terminals to -1.0000V and adjust the ZERO OFFSET control (A3R3) for a digital readout of 100.000% on the voltmeter.

(18) Increase the input voltage to the INPUT and EXTERNAL REFERENCE terminals to -10.0000 VDC. The voltmeter digital readout should be 100.000% ± 5 digits.

(19) If step (18) fails to yield 100.000% ± 5 digits, repeat steps (16) and (17) until a setting for the ZERO OFFSET control (A3R3) is found that will produce a digital readout of 100.00090 for - 1.0000 VDC and 100.00% ± 5 digits for -10.0000 VDC applied to the INPUT and EXTERNAL REFERENCE terminals.

(20) Apply -100.000 VDC to the EXTERNAL REFERENCE terminals.

(21) Connect a shorting jumper across the INPUT terminals.

(22) Connect the low side of a differential voltmeter to A9TP7 and the high side to A9TP5.

(23) Adjust the 100V CAL control (A3R6) to obtain a reading in the range of +6.999975 and 7.000025 volts on the differential voltmeter.

(24) On the voltmeter, select the 100V range.

(25) Apply -100 VDC to the INPUT and EXTERNAL REFERENCE terminals.

(26) Adjust the 100V COMMON MODE control (A3R8) to obtain a reading in the range of +6.999975 to 7.000025 VDC on the differential voltmeter.

(27) Apply -10.600 VDC to the INPUT and EXTERNAL REFERENCE terminals. Insure that the 100V range switch is depressed.

(28) Set the RANGE LEVEL control (A3R50) to its fully counterclockwise position.

(29) Adjust the RATIO FULL SCALE control to obtain a digital display of 100.000% on the voltmeter.

(30) Slowly turn the RANGE LEVEL

control (A3R50) until the digital display changes to 100.00% \pm 50 digits).

(31) Reduce the voltage to the INPUT and EXTERNAL REFERENCE terminals to -10.000 VDC. Note that the digital display again indicates 100.000%.

(32) Increase the voltage to the INPUT and

EXTERNAL REFERENCE terminals in 0.1 VDC increments. At - 10.5 VDC, the voltmeter should read 100.000 %, but at -10.6 VDC, should read 100.00% \pm 50 digits). If the range change does not occur between -10.5 VDC and 10.6 VDC, repeat steps (27) through (31).

CHAPTER 7

MATERIEL USED IN CONJUNCTION WITH AN/ GSM-64B

Section 1. INTRODUCTION TO PL-1370 / GSM-64B

7-1. Scope

This chapter describes the installation, operation, functioning, and maintenance of Plug-In, Electronic Test Equipment PL-1370/GSM-64B (ac converter) (fig. 7-3). Instructions are provided for installation and operation, trouble-shooting, testing, and repair of the equipment, as well as replacement of maintenance parts.

7-2. Purpose and Use

The PL-1370/GSM-64B is a true rms ac to dc converter used with Voltmeter, Digital AN/GSM-64B The ac converter adds rms voltage measuring capabilities to the voltmeter. Equipped with the ac converter, the AN/GSM-64B is capable of measuring rms voltages from 0 to 1,100 volts ac. Capacitive input coupling, or direct input coupling, to the ac converter can be selected by the operator. This provides the capability of measuring ac signals exclusive of any dc components or composite ac-dc signals.

7-3. Description

The PL-1370/GSM-64B is a plug-in printed circuit board assembly. This assembly, on initial receipt, is installed in Voltmeter, Digital AN/GSM-64B. The voltmeter contains an existing prewired receptacle for the ac converter assembly.

7-4. Technical Characteristics

Performance data for the PL-1370/GSM-64B is listed below:

- Ranges 1,10,100,1,000vac.
- Overrange 20 percent, 1,100 volts rms maximum on 1,100-volt range.
- Resolution 0.001-percent range.
- Overload 1,100 volts rms any range (1,500 volt peak ac).
- Superimposed dc (ac only) 1,100 volts dc (peak ac plus dc may not exceed ± 1,500 volts).
- Maximum crest factor 7 at full scale and increasing down scale per:

$$7X \sqrt{\frac{V_{range}}{V_{input}}}$$

Accuracy, 90 days (18° C (64.4°F) to 28° C (82.4° F)) (0.001 volts to 1,100 volts):

	<i>Ac + dc</i>
Dc	± (0.1% of input + 0.03% of range),
50 Hz to 10k Hz	± (0.1% of input + 0.03% of range).
10 to 30 kHz	± (0.2% of input + 0.06% of range).
30 to 50 kHz	± (0.3% of input + 0.12% of range),
20 to 50 Hz	± (0.5% of input + 0.03% of range).
10 to 20 Hz	± (1.0% of input + 0.06% of range).
50 to 100 kHz	± (1.0% of input + 0.3% of range).
100 to 300 kHz	± (2.0% of input + 0.5% of range),

	<i>Aconly</i>
50 Hz to 10 kHz	± (0.1% of input + 0.012% of range).
10 to 30 kHz	± (0.2% of input + 0.04% of range).
30 to 50 kHz	± (0.3% of input + 0.1% of range),
20 to 50 Hz	± (0.5% of input + 0.012% of range).
10 to 20 Hz	± (1.0% of input + 0.04% of range).
50 to 100 kHz	± (1.07% of input + 0.3% of range).
100 to 300 kHz	± (2.0% of input + 0.5% of range).

- Temperature coefficients (0° C to 18° C and 28° C to 50° C):
 - Dc and 10 Hz to 10 kHz (a c + d c) ± (0.004% of input + 0.004% of range).
 - 10 Hz to 10 kHz (ac only) .. ± (0.04% of input + 0.001% of range).
- Input impedance 1 megohm, shunted by less than 150pf
- Noise rejection (common mode (with up to 100-ohm unbalance in either lead):
 - Dc to 60 Hz Greater than 120 db.
- Response time (to a reading within 0.1 percent of range when measuring step change. inputs and using external trigger. For readings less than 10 percent of range. double indicated times.)

Filterout	100 milliseconds maximum ²
Filter in	500 milliseconds maximum.

²Input volt x Hertz, product should not exceed 2×10^7 .

³Above 400 Hz for rated accuracies.

¹With inputs above 500 volts, multiply accuracy by

$$\frac{2000 \text{ V} + V_{\text{input}}}{2000 \text{ V}}$$

Section II. OPERATION OF PL-1370 / GSM-64B

7-5. Installation and Removal Instructions

The ac converter kit contains a new guard cover for the voltmeter and the ac converter plug-in assembly. Installation and removal instructions are given in a and b below, respectively.

a. Installation.

(1) Be sure that the voltmeter is disconnected from the power source.

(2) Refer to figure 2, Appendix B. Remove top cover (2) and guard cover (10) from voltmeter. Retain guard cover so that the voltmeter can be restored to its original configuration should it be necessary to turn-in the voltmeter and retain the ac converter.

(3) Use figure 7-1 as a guide and locate the ac converter assembly position in the voltmeter.

(4) Align the ac converter assembly with the card guides at front and rear card bulkheads. Plug the ac converter assembly into mating connector J13. Make sure that the board edge connector and mating connector are fully engaged.

(5) Route the cable assembly from the ac converter assembly through the rubber grommet above the front card guide.

(6) Attach red and black wires to terminals of grey terminal block at front bulkhead. Refer to terminal block (I, fig. 7-1) for connecting points.

(7) Install the replacement guard cover. Set the input coupling switch, which can be reached through the guard cover, to ac or dc.

(8) Reinstall the top cover.

(9) The voltmeter can now be used to make true rms voltage measurements.

b. Removal. If it is necessary to remove the ac converter assembly prior to turn-in of the voltmeter for any reason, proceed as follows:

(1) Disconnect the voltmeter from the power source.

(2) Refer to figure 2, Appendix B. Remove top cover cover (2) and guard cover (10) from the voltmeter. Retain the guard cover for future use with the ac converter assembly.

(3) Use figure 7-1 as a guide to locate the ac converter assembly position in the voltmeter.

(4) Disconnect red and black wires from terminals of grey terminal block at front bulkhead.

Refer to terminal block (I, fig. 7-1) for connection points.

(5) Withdraw the cable assembly from the ac converter assembly from the rubber grommet above the front card guide.

(6) Remove the ac converter assembly from the voltmeter by pulling the circuit card straight up.

(7) Install the guard cover which was retained when the ac converter was installed into the voltmeter.

(8) Reinstall the top cover.

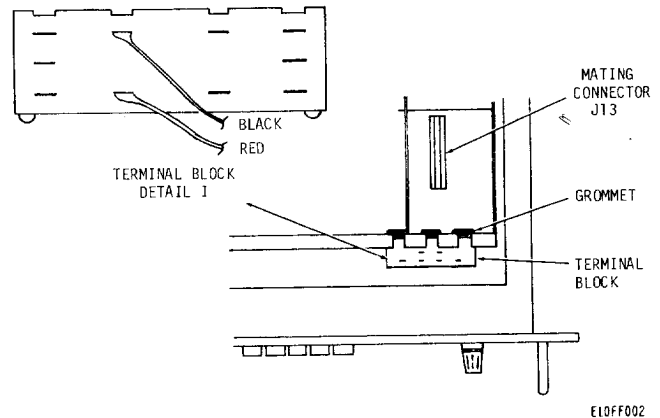

Figure 7-1. Ac converter, location diagram.

7-6. Precautions and Operator's Controls

The ac converter is fully protected from overloads applied to the INPUT terminals of the voltmeter. The ac converter can withstand overloads up to 1,100 vrms (1,500 volts peak ac) on any range. When operated with ac coupling, maximum dc input is 1,100 volts on any range. Peak ac plus dc must not exceed $\pm 1,500$ volts. Controls used for rms voltage measurements are the VAC push-button and all RANGE pushbuttons as described in paragraph 3-4. The only control unique to the ac converter is the input coupling switch which can be reached through the guard cover. This control is used to select either ac coupling (blocks superimposed dc) or dc coupling (passes composite ac + dc signals).

7-7. Preliminary Starting Procedures

The following procedures describes operation of the AN/GSM-64B as an rms voltmeter. To operate the voltmeter in other modes, refer to Chapter 3.

a. If it is desired to change input coupling, remove the voltmeter dust cover and set the input coupling switch to ac or dc.

b. Connect the voltmeter line cord to the power source.

c. Disconnect the test leads from the INPUT terminals.

d. Set the voltmeter controls as follows:

(1) POWER switch to ON.

(2) SAMPLE RATE control fully clockwise.

e. Push VDC pushbutton and 10 RANGE pushbutton.

f. Connect shorting jumper between HI and LO INPUT terminals. Check to see that GUARD terminal is connected to LO INPUT terminal.

g. Rotate DC ZERO control to obtain a readout of 00.0000.

h. Disconnect the shorting jumper from the INPUT terminals and reconnect test leads.

i. Press the VAC pushbutton and desired RANGE pushbutton.

7-8. Initial Adjustments

The following checks can be performed to check correct operation of the ac converter.

a. Perform preliminary starting procedure (para 7-7).

b. Connect the voltmeter to an ac source. (Ac source must have outputs of 1, 10, 100, and 1,000 volts at 500 Hz \pm 0.03 percent.)

c. Set the voltmeter RANGE switch to AUTO. Set the ac source to the following voltages at 500 Hz. Check to see that the voltmeter readout is within tolerance listed:

<i>Ac source output</i>	<i>Voltmeter indication</i>
1 vrms	0.99870 to 1.00130
10 vrms	9.9870 to 10.0130
100 vrms	99.870 to 100.130
1000 vrms	998.70 to 1001.30

d. Set the ac source to zero output and disconnect the voltmeter.

7-9. Ac Voltage Measurement

a. To change the input coupling, remove the voltmeter top cover and set the INPUT coupling switch to ac or dc.

b. Connect the voltmeter line cord to power source.

c. Press the VAC pushbutton and desired RANGE pushbutton.

d. After completing ac voltage measurements, place the voltmeter in standby or shutdown status by following the procedure given in paragraph 3-11 or 3-12, respectively.

Section II 1. FUNCTIONING OF PL-1370 / GSM-64B

7-10. Introduction

This section describes the functioning of Plug-In, Electronic Test Equipment PL-1370/GSM-64B. It covers the interaction between the major circuit elements of the ac converter through a block diagram and detailed circuit description. Refer to figure 7-2 for the block diagram and figure FO-12 for the detailed schematic diagram of the ac converter.

7-11. Block Diagram Description

a. The ac converter provides a dc voltage, proportional to the rms value of the applied input voltage, to the A/D converter of the AN/GSM-64B. This dc voltage is digitized by the A/D converter and subsequently displayed as a front panel readout. A simplified diagram of the circuits involved in the rms conversion process is shown in figure 7-2.

b. The ac converter consists of a range amplifier and rms detector. The output voltage from the range amplifier is 1 volt rms maximum, for a full scale input voltage. A scaled output voltage from the range amplifier is applied to the rms detectors balance amplifier where any negative-going signals are inverted. The output of the balance amplifier is summed with the output of the range amplifier at the summing junction of the squaring amplifier. This action provides a rectified version of the range amplifier output. The rectified signal is processed by the squaring amplifier, integrating amplifier, and square root amplifier, respectively. These three amplifiers perform squaring, integrating, and square rooting functions which result in a dc voltage proportional to the rms value of the INPUT terminal voltage.

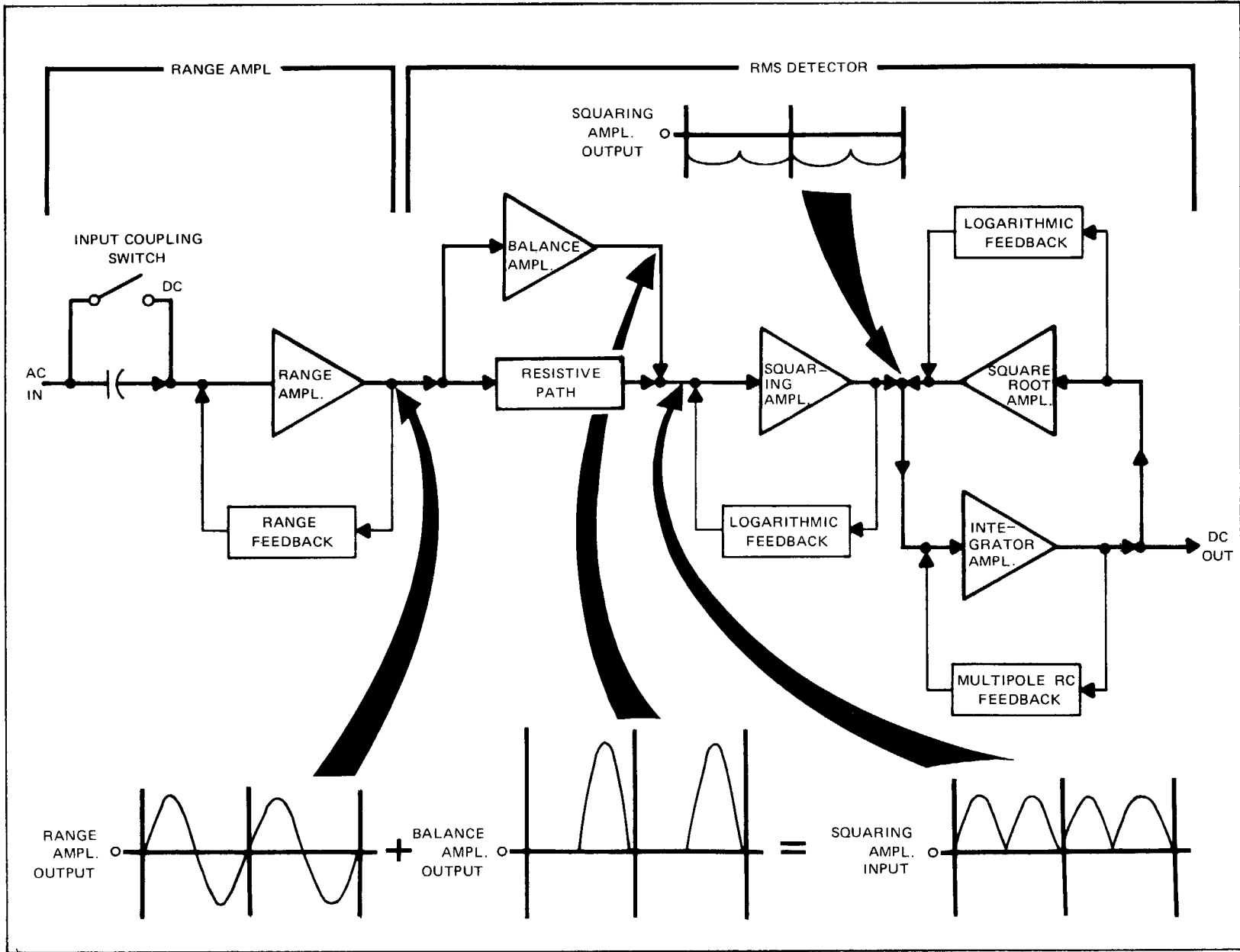

ELOFF003

Figure 7-2. Ac converter, block diagram.

7-12. Circuit Description

(fig. FO-12)

a. Range Amplifier. The range amplifier scales the applied input voltage to the ac converter to 1 volt rms for a full scale input. Basically, the range amplifier is an inverting operational amplifier whose gain changes as the range changes. Voltage gains of -1, -10, -100, and -1000 correspond with the 1 through 1,000-volt ranges of the AN/GSM-64B. Active elements of the range amplifier are Q1, Q2, Q5, and U3 with protection diodes CR6, CR7, CR12, CR13, CR18, CR20, CR21, and CR22. Transistor Q2 drives the guard at the summing point potential of the operational amplifier. FET Q5 switches C5 into the feedback path in the 10-, 100-, and 1,000-volt ranges. Diodes CR6, CR7, CR21, and CR22 provide clipping for input overload protection to Q1. Diodes CR18 and CR20 provide overload clipping at the output of the range amplifier for protection of the rest of the ac converter circuits.

b. Balance Amplifier. The balance amplifier is a rectifying amplifier with a gain of -1. This amplifier changes all negative-going signals from the range amplifier output to positive voltages. Balance gain adjustment (R32) controls the input to the balance amplifier. The control is adjusted so that positive and negative signals at the output of the balance amplifier (junction of R31, R33, and U5) will be equal in magnitude. Active components of the balance amplifier are CR15, Q6, Q9, Q10, and U4. Balance zero adjustment, R42, is an adjustment for zeroing the input of U4. The primary or low frequency signal path is through U4, CR15, and final output stage Q10. At frequencies above a few hundred kilohertz, the signal path is through Q6 and Q10. Transistor Q10 has a current source load, CL1, which maintains a high amplifier output impedance for driving rectifiers CR14 and CR16. Any stray capacitance in CR14 and CR16 is compensated by Q9. Amplifier feedback is through Q9 and C17.

c. Squaring Amplifier. The squaring amplifier is an inverting operational amplifier with nonlinear feedback through matched transistors Q8A and Q12A. These transistors transform the input current into an output voltage that is twice the log of the input current. Since two times the log of a number is equal to the log of the number squared, the amplifier essentially causes a squaring operation. The main signal path is through U5 and Q11. At high frequencies, Q7 parallels U5. Zero offset at the input to U5 is compensated by ac zero adjustment, R45. This adjustment has the greatest effect for overall ac converter zero. Output voltage

from final stage Q11 is converted to a current by Q12B. Adjustment of crest factor gain is with R38.

d. Integrator Amplifier. The integrator amplifier consists of U7 and U8. It is a complex multipole integrator which acts as a three-pole filter. Currents at the summing junction of U7-2 are integrated by U7 and its three poles of feedback, C30, R68 and C32, and R69 and C33. Additional filtering is provided when the FILT button on the voltmeter front panel is depressed. This action initiates a command through P13-10 and enables Q18 and Q15. With these transistors enabled, FET switches Q13, Q14, Q16, and Q17 switch additional feedback capacitors across the existing three poles. Capacitor C29 is switched in parallel with C30; C34 with C32; C35 with C33; and C28 with C27. The output of the integrator amplified is buffered by U8. Output from U8 is distributed to the square root amplifier. The output is also directed through K2B and P13-12 to the A-to-D converter.

e. Square Root Amplifier. The square root amplifier consists of input resistor R57, trimming and selection resistors R61, R62, R63, and R64, feedback transistor Q8B, protection diode CR19, and amplifier U6. Diode CR19 acts as a feedback path to prevent saturation of U6, should input polarity to the amplifier reverse. The amplifier uses logarithmic feedback to produce the square root of its input in a way similar to that used in the squaring amplifier. The square root process is accomplished by matched transistors Q8B and Q12B. Resistors R48, R79, and R80 are factory selected for overall ac converter temperature coefficient and linearity. Some, or none, of these resistors may be installed.

f. Relay Controls. Ac converter input coupling is controlled manually by switch S1. Closing S1 (dc coupling) activates relay K3, which causes capacitor C1 to be bypassed. This action allows measurements of composite ac/dc signals. Placing S1 to ac coupling deactivates K3 which places the dc blocking capacitor (C1) in the input circuit. Input and output relays K1 and K2 are operated from the vac function control line. The range relays, K4, K5, and K6, are operated by driver circuitry, consisting of NAND gates U2A, C, D and current source transistors Q3 and Q4. These range control gates accept the buffered outputs of the range counter on the display board (A14). Integrated circuits U1B and U2B deliver the up and down range stop commands, for vac function, to the range delay board. NAND gates U1A and U1C deliver the set and reset commands to the range counter, on the display board, for prevention of a disallowed range in the vac function.

Section IV. TROUBLESHOOTING AND REPAIR OF PL-1370 / GSM-64B

NOTE

No additional tools and test equipment are required to troubleshoot and repair the ac converter other than those listed in paragraph 6-5.

7-13. Removal and Replacement

The ac converter must be placed on an extender card to perform troubleshooting procedures.

a. Removal,

(1) Disconnect the voltmeter from the power source.

(2) Remove the top cover (2) and the guard cover (10) from the voltmeter (fig. 2, appx B).

(3) Remove the ac converter from the inner chassis.

b. Replacement.

(1) Align the ac converter with the card guides at the front and rear card bulkheads.

(2) Plug the ac converter into mating connector J13. Be sure that the board edge connector and mating connector are fully engaged.

(3) Be sure that the cable assembly from the ac converter is routed properly and the rubber grommet is in place.

(4) Secure the guard and top covers in place.

(5) Reconnect the voltmeter to the power source.

7-14. Performance Check

a. Insure that the malfunction is in the instrument and not because of improper operation. Perform a thorough visual inspection of the ac converter for loose or broken wires, damaged parts, etc. If no physical damage is noticed, check the performance characteristics of the ac converter. Refer to table 7-1 and connect the TS-682/GSM - 1 to the INPUT terminals of the voltmeter and apply the listed inputs to the voltmeter for vac measurement with ac input coupling. Continue troubleshooting by performing the voltage measurements listed in paragraph 7-15.

b. A detailed schematic diagram of the ac converter is shown in figure FO-12. For parts location, refer to figure 15, appendix B. Test point locations are shown on figure 7-1.

c. Remove the ac converter from the voltmeter (para 7-13) and insert the extender card in its place. Connect the ac converter to the extender card. Be sure that all connections are tight. Reconnect the voltmeter to the power source. Perform the required measurements.

Table 7-1. Performance Checks

Input		Voltmeter range	Voltmeter indication
Voltage	Frequency		
500	500 Hz	1000	499.44 to 500.56
500	50 kHz	1000	493.50 to 506.50
1.0	500 Hz	1	0.99888 to 1.00112
1.0	50 kHz	1	0.98700 to 1.01300
10.0	500 Hz	10	9.9888 to 10.0112
10.0	50 kHz	10	9.8700 to 10.0130
100	500 Hz	100	99.888 to 100.112
100	50 kHz	100	98.700 to 101.300

7-15. Voltage Measurements

Applicable dc voltages for the ac converter check-points are listed in tables 7-2, 7-3, and 7-4. The ac converter must be placed on the extender card to make these tests. Remove the ac converter from the voltmeter by following the directions given in paragraph 7-13. Insert the extender card in its place and connect the ac converter to the extender card. Be sure that all connections are secure. When measurements have been completed, remove the

extender card and insert the ac converter into the voltmeter.

a. Test Point Voltage Measurements. Perform the voltage measurements listed in table 7-2. Use the AN /USM -98 (differential voltmeter) and set the AN/GSM-64B as follows:

(1) Place the shorting bar across the INPUT terminals.

(2) RANGE switch to 1.

(3) FUNCTION switch to FILTER.

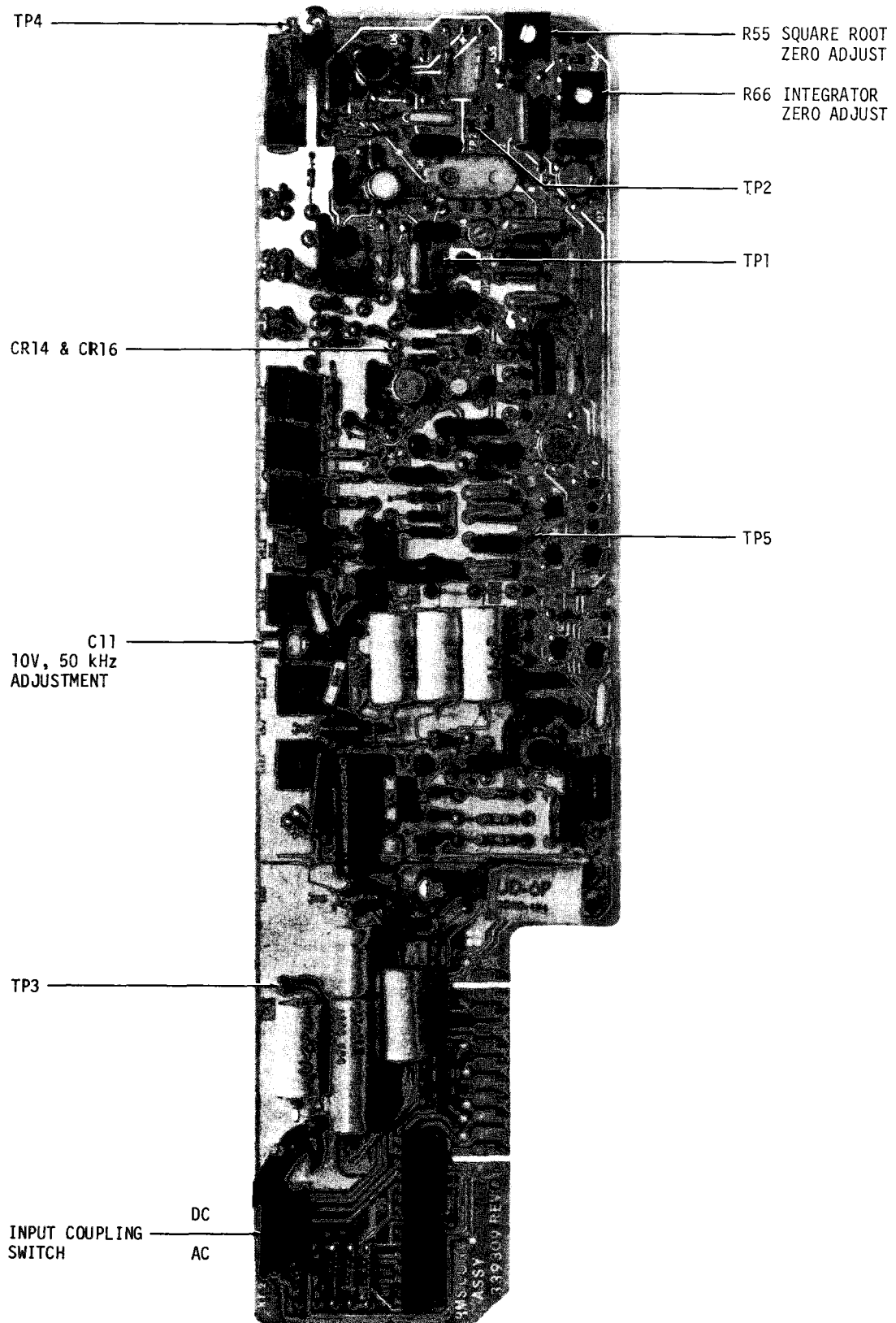

ELOFF001

Figure 7-3. Plug-in, Electronic Test Equipment PL1370/GSM-64B, test point locations.

Table 7-2. Voltage Measurements

Checkpoint	Dc voltage	Checkpoint	Dc voltage
P13 pin 19 (board edge connector).	+18 v ± 50 mv	Q4 collector	-12 ± 2 v
P13 pin 21	-18 v ± 0.5 v	Q5 gate	-11.5 ± 2.5 v
TP1	-0.5 v ± 0.2 v	Q9 emitter	0V ± 0.2 v
TP2	0V ± 1 v	Q10 base	-16.4 v ± 0.5 v
TP3	0V	Q10 collector	+0.5 v ± 0.1 v
TP4	0V ± 100 uv	Q10 emitter	-17 v ± 0.5 v
U3 pin 6	0V ± 50 uv	Q11 base	-0.5 v ± 0.2 v
U4 pin 3	0V ± 2 mv	Q14	-18 v ± 50 mv
U4 pin 6	-6.4 v ± 1 v	Q15	-0.5 v ± 0.2 v
U5 pin 3	0V ± 5 mv	CR8 cathode	+5 v ± 0.5 v
U6 pin 2	0V ± 5 mv	CR9 cathode	+5 v ± 0.5 v
U7 pin 2	0V ± 5 mv	CR10 cathode	+5 v ± 0.5 v
U8 pin 3	0V ± 2 mv		

b. Power Supply Voltage Measurements. Each of the supply voltages for the ac converter is measured at the pin connectors of board edge connector P13. This check verifies only presence of operating voltages. A detailed check of the voltmeter power supply voltages will be found in Chapter 6.

(1) Connect the differential voltmeter between P13 pin 19 and common (shield); the indication should be + 18 vdc.

(2) Connect differential voltmeter between P13 pin 21 and common; the indication should be - 18 vdc.

c. Command Voltage Measurements. Check for proper command voltages for ranging in the ac converter as follows:

(1) Be sure that VAC pushbutton is depressed.

(2) Connect the differential voltmeter between P13 pins listed in table 7-3 and common. The measured voltages should agree with the logic symbols opposite the pin number and under the voltage range heading. A logical 1 (one) equals a measured voltage more than 3.0 volts and a logical 0 (zero) indicates a measured voltage less than 0.6 volt. Refer to (3) below for possible sources of trouble if a logic indication is wrong.

Table 7-3. Ac Converter Function Command Check

P13 Pin No.	Range (volts)			
	1	10	100	1000
18	0	1	1	0
2	1	0	0	0
8	1	1	1	1
4	0	1	0	1
3	1	0	0	1
6	0	1	1	1
16	1	0	1	0

NOTE

Logical 1 = > 3.0 volts.
 Logical 0 = < 0.6 volt.

(3) Incorrect logic indications can be caused by misaligned connector pins; faulty FUNCTION switch; defective range counter on the display pcb; defective RANGE switch; defective ac converter relay gates; or a short circuit between ac converter control lines.

d. Relay Voltage Measurements. Table 7-4 will help in locating defective relays or associated relay driver circuits. If the voltage across the relay coils does not appear as indicated in table 7-4, the relay drive circuit is at fault. Perform the command voltage measurements in c above before making this test. If the coil voltages are correct, but a relay fails to respond, the relay is defective. Logic 1 and 0 is used in table 7-4. A logic 1 indicates a measured voltage of more than 4.0 volts and a logic 0 indicates a measured voltage less than 0.6 volt.

Table 7-4. Ac converter relay Truth Table

Relay	Range (volts)			
	1	10	100	1000
K1	1	1	1	1
K2	1	1	1	1
K4	0	1	0	0
K5	0	0	1	0
K6	0	0	0	1

NOTE

Logical 1 = > 4.0 volts
 Logical 0 = < 0.6 volt.

7-16. Circuit Isolation

Turn the voltmeter on and allow it to operate for at least 10 minutes. Erroneous indications can occur if sufficient warmup is not allowed.

a. Disconnect the voltmeter from the power source. Remove the top and guard covers. Extend the ac converter from the voltmeter inner chassis with the extender card provided (para 7-13).

b. Connect the voltmeter to the power source

and set the POWER switch to ON. Depress the VAC pushbutton.

c. Connect the differential voltmeter between TP4 and common (shield).

d. Short HI to LO INPUT terminals. The indication should be within 100 millivolts of zero. If indication is incorrect, proceed to *f* below; otherwise proceed to the next step.

e. Remove the input terminal short and apply a full range voltage to the voltmeter input at 500 Hz. The differential voltmeter should indicate between 9.95 to 10.05 volts when connected between TP4 and common (shield). If indication is incorrect, proceed to *j* below; otherwise proceed to the next step.

f. Remove any input voltage or short at the input terminals. Short TP1 to common (shield). If the indication changes to within 100 millivolts of zero, proceed to *j* below; otherwise proceed to the next step.

g. Short test points TP1 and TP2 to test point TP5.

h. Connect the differential voltmeter high lead to test point TP4. The indication should be within 100 microvolts of zero and be adjustable with R66 (integrator amplifier zero). If indication is incorrect, troubleshoot the integrator amplifier circuit. Refer to table 7-1 and perform the measurements for U7, U5, Q14, Q15, and TP4.

i. Remove short at test point TP2 (maintain short between test point TP1 and common). Connect the high lead of the differential voltmeter to TP2. The indication should be within 200 millivolts of zero and be adjustable with R55 (square root amplifier zero adjust). If the indication is incorrect, troubleshoot the square root amplifier circuit. Refer to table 7-1 and perform the measurements for U6 and TP5.

j. Remove any input voltage and disconnect the differential voltmeter and all shorts.

k. Connect the oscilloscope with low capacitance probe between the threaded body of C11 (10 volts 50 kHz adjust) and common.

l. With no voltage applied to the INPUT terminals the oscilloscope should display zero volt. With a full range voltage at 500 Hz applied to the INPUT terminals, the oscilloscope should display a clean sine wave of 2.8 volts peak-to-peak. If the indication is incorrect, troubleshoot the range amplifier circuit. Refer to table 7-1 and perform the measurements for U3, TP3, and Q5.

m. Move the oscilloscope probe to cathode of CR16 or anode of CR14.

n. With no input voltage applied to the INPUT terminals, the oscilloscope should indicate within 100 millivolts dc of zero. With a full range voltage at 500 Hz applied to the INPUT terminals, the oscilloscope should display a clean halfwave rectified sine wave of 1.4 volts peak. If the indication is incorrect, troubleshoot the balance amplifier circuit. Refer to table 7-2 and perform the measurements for U4, Q9, and Q10.

o. Move the oscilloscope probe to test point TP1.

p. With no voltage applied to the INPUT terminals, the oscilloscope should indicate within 100 millivolts of zero. With a full range voltage at 500 Hz applied to the INPUT terminals, the oscilloscope should display approximately — 1.2 volts dc with a clean ac scallop superimposed. If the display is incorrect, troubleshoot the squaring amplifier circuit. Refer to table 7-2 and perform the measurements for U5, TP1 and Q11.

7-17. Matched Set Replacement

The ac converter contains a set of factory selected components. This set consists of Q8, Q12, R48, R79, and R80. These components are selected for overall ac converter temperature coefficient and linearity. In case of replacement, the total set must be installed. Depending on the matched set received for replacement, some, or none, of the three resistors may be included. In positions where a resistor is not required, install a piece of bus wire.

7-18. General Support Testing

a. Adjustment of the ac converter is not authorized at the General Support level. If the PL-1370/GSM-64B fails to meet the parameters required in *b* below, the item must be sent for calibration.

b. After repairs have been made to the ac converter, install the item into a working voltmeter. Set the voltmeter for vac measurement with ac input coupling. Connect the TS-682/GSM - 1 to the INPUT terminals of the voltmeter. Apply the input signals listed in table 7-1, set the appropriate range and observe the output indication on the voltmeter. The output should be between the values listed in the voltmeter indication column.

APPENDIX A

REFERENCES

-
- | | |
|--------------|---|
| DA Pam 310-4 | Index of Technical Manuals, Technical Bulletins, Supply Manuals (types 7,8, and 9), Supply Bulletins, and Lubrication Orders. |
| DA Pam 310-7 | US Army Equipment Index of Modification Work Orders. |
| SB 38-100 | Preservation, Packaging, Packing and Marking Materials, Supplies, and Equipment Used by the Army. |
| TM 38-750 | The Army Maintenance Management System (TAMMS). |
| TM 740-90-1 | Administrative Storage of Equipment. |

APPENDIX B

OPERATOR'S, ORGANIZATIONAL, DIRECT SUPPORT,
AND GENERAL SUPPORT MAINTENANCE REPAIR
PARTS AND SPECIAL TOOLS LIST

Section 1. INTRODUCTION

B-1. Scope

This appendix lists basic issue items; Items Troop Installed or Authorized and repair parts required for operation and performance of general support maintenance of the AN/GSM-64B and PL-1370/GSM-MB.

B-2. General

This Basic Issue Items, Items Troop Installed or Authorized, Repair Parts and Special Tools List is divided into the following sections:

a. Section II—Basic Issue Items List. A list, in alphabetical sequence, of items which are furnished with and which must be turned in with the end item.

b. Section III—Items Troop Installed or Authorized List. A list in alphabetical sequence, of items, which at the discretion of the unit commander, may accompany the end item, but should not be turned in with the end item.

c. Section IV—Repair Parts List. A list of repair parts authorized for use in the performance of maintenance. The list also includes parts which must be removed for replacement of the authorized parts. Parts lists are composed of functional groups in ascending numerical sequence, with the parts in each group listed in figure and item number sequence.

d. Section V—Special Tools List. Not applicable.

e. Section VI—National Stock Number and Part Number Index. A list, in ascending numerical sequence of all National stock numbers appearing in the listings, followed by a list, alphanumeric sequence, of all part numbers appearing in the listings. National stock numbers and part numbers are cross-referenced to each illustration figure and item number appearance.

B-3. Explanation of Columns

The following provides an explanation of columns found in the tabular listings:

a. Illustration. This column is divided as follows:

(1) *Figure number.* Indicates the figure number of the illustration in which the item is shown.

(2) *Item number.* The number used to identify each item called out in the illustration.

b. Source, Maintenance, and Recoverability Codes (SMR).

(1) *Source code.* Source codes are assigned to support items to indicate the manner of acquiring support items for maintenance, repair, or overhaul of end items. Source codes are entered in the first and second positions of the Uniform SMR Code format as follows:

<i>Code</i>	<i>Definition</i>
PA	Item procured and stocked for anticipated or known usage.
KF	An item of a maintenance kit and not purchased separately. Maintenance kit defined as a kit that provides an item that can be replaced at organizational or intermediate levels of maintenance.
XB	Item is not procured or stocked if not available through salvage, requisition.
XD	A support item that is not stocked, when required, item will be procured through normal supply channels. Cannibalization or salvage may be used as a source of supply for any items source coded above except those coded XA, XD and Aircraft support items as restricted by AR700-42.

(2) *Maintenance code.* Maintenance codes are assigned to indicate the levels of maintenance authorized to USE and REPAIR support items. The maintenance codes are entered in the third and fourth positions of the Uniform SMR Code format as follows:

(a) The maintenance code entered in the third position will indicate the lowest maintenance level authorized to remove, replace, and use the

support item. The maintenance code entered in the third position will indicate the following level of maintenance:

Code *Application/Explanation*

H - Support item is removed, replaced, used at the general level.

(b) The maintenance code entered in the fourth position indicates whether the item is to be repaired and identifies the lowest maintenance level with the capability to perform complete repair (i.e., all authorized maintenance functions). This position will contain one of the following maintenance codes:

Code *Application/Explanation*

H - The lowest maintenance level capable of complete repair of the support item is the general support level.

Z - Nonreparable. No repair is authorized.

(3) *Recoverability code*. Recoverability codes are assigned to support items to indicate the disposition action on unserviceable items. The recoverability code is entered in the fifth position of the Uniform SMR Code format as follows:

Recoverability code *Definition*

H - Repairable item. When uneconomically repairable condemn and dispose at the general support level.

Z - Nonreparable item. When unserviceable, condemn and dispose at the level indicated in position 3.

c. *National Stock Number*. Indicates the National stock number assigned to the listed item and will be used for requisitioning purposes.

d. *Part Number*. Indicates the primary number used by the manufacturer (individual, company, firm, corporation, or Government activity), which controls the design and characteristics of the item by means of its engineering drawings, specifications standards, and inspection requirements, to identify an item or range of items. For BIIL and ITIAL, see explanation of description column, f below.

NOTE

When a stock-numbered item is requisitioned, the repair part received may have a different part number than the part being replaced.

e. *Federal Supply Code for Manufacturer (FSCM)*. The FSCM is a 5-digit numeric code listed in SB 708-42 which is used to identify the manufacturer, distributor, or Government agency, etc. For BIIL and ITIAL, see explanation of description column, f below.

f. *Description*. Indicates the Federal item name and, if required, a minimum description to identify

the item. The last line for each item in the BIIL and ITIAL indicates the part number with the FSCM in parentheses. Items that are included in kits and sets are listed below the name of the kit or set with the quantity of each item in the kit or set indicated in the quantity incorporated in unit column.

g. *Unit of Measure (U/M)*. Indicates the standard of the basic quantity of the listed item as used in performing the actual maintenance function. This measure is expressed by a two-character alphabetical abbreviation (e. g., ea, in, pr, etc.). When the unit of measure differs from the unit of issue, the lowest unit of issue that will satisfy the required units of measure will be requisitioned.

h. *Quantity Furnished With Equipment (Basic Issue Items Only)*. Indicates the quantity of the basic issue item furnished with the equipment.

i. *Quantity Authorized (Items Troop Installed or Authorized Only)*. Indicates the quantity of the item authorized to be used with the equipment.

j. *Quantity Incorporated in Unit*. Indicates the quantity of the item used in the breakout shown on the illustration figure, which is prepared for a functional group, sub functional group, or an assembly.

B-4. Special Information

a. Repair parts kits and gasket sets appear as the last entries in the repair parts listing for the figure in which its parts are listed as repair parts.

b. Action change codes indicated in the left-hand margin of the listing page denote the following:

N - Indicates an added item.

C - Indicates a change in data.

R - Indicates a change in NSN only.

B-5. How to Locate Repair Parts

a. When National stock number or part number is unknown:

(1) *First*. Using the table of contents, determine the functional subgroup within which the repair part belongs. This is necessary since illustrations are prepared for functional subgroups and listings are divided into the same groups.

(2) *Second*. Find the illustration covering the functional subgroup to which the repair part belongs.

(3) *Third*. Identify the repair part on the illustration and note the illustration figure and item number of the repair part.

(4) *Fourth*. Using the Repair Parts Listing, find the figure and item number noted on the illustration.

b. When National stock numbers and part numbers is unknown:

(1) *First.* Using the Index of National Stock Numbers and Part Numbers, find the pertinent National stock number or part number. This index is in ascending alphanumeric sequence, cross-referenced to the illustration figure number and item number.

(2) *Second.* After finding the figure and item number, locate the figure and item number in the repair parts list.

B-6. Abbreviations

(Not applicable)

SECTION II. BASIC ISSUE ITEMS LIST

(1) ILLUSTRATION		(2) NATIONAL STOCK NUMBER	(3) DESCRIPTION	(4) QTY FURN WITH EQUIP
(A) FIG. NO.	(B) ITEM NO.			
1	1		CARD, EXTENDER 298265 (89536)	1
1	2	6625-00-893-7165	KIT, TEST LEAD 20857 (83330)	1

SECTION III. ITEMS TROOP INSTALLED OR AUTHORIZED LIST

(1) NATIONAL STOCK NUMBER	(2) DESCRIPTION PART NUMBER AND FSCM	(3) U M	(4) QTY AUTH
525-0 0-137-8366	PLUG-IN ELECTRONIC TEST EQUIPMENT (EQUIPMENT PL-1 370 ASM-64B (80058))	EA	1

SECTION IV. REPAIR PARTS LIST

(1) ILLUSTRATION		(2) SMR CODE	(3) NATIONAL STOCK NUMBER	(4) PART NUMBER	(5) FSCN	(6) DESCRIPTION	(7) UNIT OF MEA	(8) QTY INC IN UNIT
(A) FIG NO.	(B) ITEM NO.							
GROUP: 0101 DIGITAL VOLTMETER AN/GSM-64B								
2	1	XBHZZ		333559	89536	COVER ASSEMBLY , TOP	EA	1
2	2	XBHZZ		324046	89536	COVER , TOP	EA	1
2	3	XBHZZ		333567	89536	COVER ASSEMBLY , BOTTOM	EA	1
2	4	XBHZZ		324061	89536	COVER , BOTTOM	EA	1
2	5	PAHZZ		T3R722CS	08844	FASTENER , LOCK	EA	32
2	6	PAHZZ		9102W	28708	FOOT , RUBBER	EA	4
2	7	PAHZZ		324129	89536	HOLDER , DESSICANT	EA	1
2	8	PAHZZ		6203M5	00334	INDICATOR	EA	2
2	9	PAHZZ		324137	89536	COVER , ACCESS	EA	1
2	10	PAHZZ		324145	89536	COVER , GUARD	EA	1
2	10	XDHZZ		402149	89536	COVER , GUARD(USE WITH RMS CONVERTER)	EA	1
2	11	PAHZZ		2185	83330	GROMMET	EA	1
2	12	XDHHH		331751	89536	POWER SUPPLY ASSEMBLY	EA	1
2	13	XDHHH		324772	89536	RANGE DELAY ASSEMBLY	EA	1
2	14	XDHHH		324780	89536	RATIO INPUT ASSEMBLY	EA	1
2	15	XDHHH		336057	89536	A-D CONVERTER SET	EA	1
2	16	PAHZZ		295329	89536	COVER , CONNECTOR	EA	1
2	17	PAHZZ		291807	89536	CABLE , FLAT	EA	1
2	18	XDHHH		337634	89536	PCB , LOGIC	EA	1
2	19	XDHHH		329441	89536	A-D CONVERTER ASSEMBLY	EA	1
2	20	XDHHH		337642	89536	ACTIVE FILTER ASSEMBLY	EA	1
2	21	XDHHH		324764	89536	BUFFER ASSEMBLY	EA	1
2	22	XDHHH		326462	89536	FINAL ASSEMBLY	EA	1
2	23	XDHHH		324962	89536	FRONT PANEL ASSEMBLY	EA	1
2	24	XDHHH		324970	89536	REAR PANEL	EA	1
2	25	XDHHH		324756	89536	DISPLAY ASSEMBLY	EA	1
2	26	XDHHH		324806	89536	DECIMAL LOGIC ASSEMBLY	EA	1
GROUP: 0102 POWER SUPPLY ASSEMBLY								
3	1	PAHZZ	9961-00-400-4545	60994	95303	TRANSISTOR , SILICON , NPN	EA	2
3	2	PAHZZ	9961-00-985-9073	2N3053	95303	TRANSISTOR , SILICON , NPN	EA	2
3	3	PAHZZ	9961-00-979-0108	2N4037	95303	TRANSISTOR , SILICON , PNP	EA	1
3	4	PAHZZ	9905-00-055-6121	EB5105	01121	RESISTOR , COMPOSITION : 51 ohms $\pm 5\%$, 1/2W	EA	2
3	5	PAHZZ		MFF1-81002P	91637	RESISTOR , FILM: 10K $\pm 1\%$, 1/8W	EA	2
3	6	PAHZZ	9910-00-716-4950	CD15E330J	14655	CAPACITOR , MICA: 33 pF $\pm 5\%$, 500 VDC	EA	2
3	7	PAHZZ	9962-00-563-1929	LM301A	12040	INTEGRATED CIRCUIT, OPERATIONAL AMPLIFIER	EA	2
3	8	PAHZZ	9910-00-003-4662	ET470X025A4	73445	CAPACITOR , ELECTROLYTIC: 50 uF $\pm 50/-10\%$, 25 VDC	EA	2
3	9	PAHZZ	9961-00-892-8706	2N3904	94713	TRANSISTOR , SILICON , NPN	EA	1
3	10	PAHZZ	9905-00-087-1160	EB5115	01121	RESISTOR , COMPOSITION : 510 ohms $\pm 5\%$, 1/2W	EA	1
3	11	PAHZZ	9910-00-402-0299	39D718G010JP4	56289	CAPACITOR, ELECTROLYTIC: 7100 uF $\pm 75/-10\%$, 10 VDC	EA	1
3	12	PAHZZ	9961-00-288-7401	1N4817	05277	DIODE, SILICON: 1A, 100 PIV	EA	8
3	13	PAHZZ		337618	89536	PCB , POWER SUPPLY	EA	1
3	14	PAHZZ	9961-00-497-9132	40372	95303	TRANSISTOR , SILICON , NPN	EA	1

SECTION IV. REPAIR PARTS LIST (CONTINUED)

TM 11-6625-444-14-1

(1) ILLUSTRATION		(2) SMR CODE	(3) NATIONAL STOCK NUMBER	(4) PART NUMBER	(5) FSCM	(6) DESCRIPTION	(7) UNIT OF MEAS.	(8) QTY INC IN UNIT
(A) FIG NO.	(B) ITEM NO.							
3	15	PAHZZ	5961-00-070-7481	1N4822	05277	DIODE, SILICON: 1A, 600 PIV	EA	4
3	16	PAHZZ		ET221X040A01	73445	CAPACITOR, ELECTROLYTIC: 250 uF +50/-10%, 40 VDC	EA	2
3	17	PAHZZ		39D805G350GE4	56289	CAPACITOR, ELECTROLYTIC: 8 uF +50/-10%, 350 VDC	EA	1
3	18	PAHZZ	5905-00-153-5785	360S501A	71450	RESISTOR, VARIABLE: 500 ohms $\pm 10\%$, 1W	EA	1
3	19	PAHZZ		295121	89536	RESISTOR, WI REMOUND: 7.2K ohms $\pm 0.1\%$, 1/4W	EA	1
3	20	PAHZZ		240937	89536	RESISTOR, WIREWOUND: 4.02K ohms $\pm 0.1\%$, 1/4W	EA	1
3	21	PAHZZ	5905-00-741-0744	C85625	01121	RESISTOR, COMPOSITION: 5.6K ohms $\pm 5\%$, 1/4W	EA	2
3	22	PAHZZ		MFF1-840R2F	91637	RESISTOR, FILM: 40.2K ohms $\pm 1\%$, 1/8W	EA	2
3	23	PAHZZ		MFF1-89R53F	91637	RESISTOR, FILM: 9.53K $\pm 1\%$, 1/8W	EA	1
3	24	PAHZZ	5961-00-908-9666	88000	17069	PAD, TRANSISTOR MOUNTING	EA	5
3	25	PAHZZ	5905-00-105-7765	C82245	01121	RESISTOR, COMPOSITION: 220K ohms $\pm 5\%$, 1/4W	EA	1
3	26	PAHZZ	5961-00-188-8590	1N963B	07910	DIODE, ZENER: 12 VDC	EA	1
3	27	PAHZZ		MFF1-83833F	91637	RESISTOR, FILM: 383K $\pm 1\%$, 1/8W	EA	1
3	28	PAHZZ	5905-00-119-3505	C86835	01121	RESISTOR, COMPOSITION: 68K ohms $\pm 5\%$, 1/4W	EA	1
GROUP: 0103 RANGE SUPPLY ASSEMBLY								
4	1	PAHZZ		329474	89536	PCB, RANGE DELAY	EA	1
4	2	PAHZZ		1N270	93332	DIODE, GERMANIUM: 80 MA, 100 PIV	EA	9
4	3	PAHZZ	5961-00-892-8706	2N3904	94713	TRANSISTOR, SILICON, NPN	EA	2
4	4	PAHZZ		2N6027	03508	TRANSISTOR, SILICON, UNIUNCTION	EA	1
4	5	PAHZZ		C1288101H253M	56289	CAPACITOR, CERAMIC: 0.025 uF $\pm 20\%$, 100 VDC	EA	2
4	6	PAHZZ		MFF1-81692F	91637	RESISTOR, FILM: 16.9K ohms $\pm 1\%$, 1/8W	EA	1
4	7	PAHZZ		D20F103F	53021	CAPACITOR, MICA: 0.01 uF $\pm 1\%$, 300 VDC	EA	1
4	8	PAHZZ	5905-00-156-6459	360S103A	71450	RESISTOR, VARIABLE: 10K ohms $\pm 10\%$, 1/2W	EA	1
4	9	PAHZZ		MFF1-81033F	91637	RESISTOR, FILM: 10K ohms $\pm 1\%$, 1/8W	EA	1
4	10	PAHZZ	5905-00-960-0126	C84735	01121	RESISTOR, COMPOSITION: 47K ohms $\pm 5\%$, 1/4W	EA	1
4	11	PAHZZ	5905-00-909-3885	C81035	01121	RESISTOR, COMPOSITION: 10K ohms $\pm 5\%$, 1/4W	EA	2
4	12	PAHZZ	5905-00-683-2240	C82215	01121	RESISTOR, COMPOSITION: 220 ohms $\pm 5\%$, 1/4W	EA	3
4	13	PAHZZ		MFF1-83652F	91637	RESISTOR, FILM: 36.5K ohms $\pm 1\%$, 1/8W	EA	1
4	14	PAHZZ		MFF1-81502F	91637	RESISTOR, FILM: 15.4K ohms $\pm 1\%$, 1/8W	EA	1
4	15	PAHZZ		MFF1-82742F	91637	RESISTOR, FILM: 27.4K ohms $\pm 5\%$, 1/8W	EA	1
4	16	PAHZZ	5961-00-471-2492	DND1105	03508	DIODE, SILICON: 150 MA	EA	5
4	17	PAHZZ	5905-00-911-3815	C82735	01121	RESISTOR, COMPOSITION: 27K ohms $\pm 5\%$, 1/4W	EA	2
4	18	PAHZZ	5905-00-911-3753	C84725	01121	RESISTOR, COMPOSITION: 4.7K ohms $\pm 5\%$, 1/4W	EA	2
4	19	PAHZZ		ET221X010A5	73445	CAPACITOR, ELECTROLYTIC: 200 uF +50/-10%, 10 VDC	EA	1
4	20	PAHZZ	5905-00-911-3754	C85125	01121	RESISTOR, COMPOSITION: 5.1K ohms $\pm 5\%$, 1/4W	EA	1
4	21	PAHZZ	5905-00-136-3890	C85135	01121	RESISTOR, COMPOSITION: 51K ohms $\pm 5\%$, 1/4W	EA	1
4	22	PAHZZ	5985-00-577-9461	C82235	01121	RESISTOR, COMPOSITION: 22K ohms $\pm 5\%$, 1/4W	EA	1
4	23	PAHZZ	5961-00-985-9077	2N3391	03508	TRANSISTOR, SILICON, NPN	EA	2
4	24	PAHZZ		150F335X5020I	56289	CAPACITOR, TANTALUM: 3.3 uF $\pm 5\%$, 20 VDC	EA	2
4	25	PAHZZ	5961-00-400-5364	1N276	18927	DIODE, GERMANIUM: 50 PIV	EA	2
4	26	PAHZZ	5962-00-350-8423	MC836P	04713	INTEGRATED CIRCUIT, DTL, HEX INVERTER	EA	1
4	27	PAHZZ	5962-00-350-8424	MC862P	04713	INTEGRATED CIRCUIT, DTL, NAND GATE	EA	1

SECTION IV. REPAIR PARTS LIST (CONTINUED)

(1) ILLUSTRATION		(2) SMR CODE	(3) NATIONAL STOCK NUMBER	(4) PART NUMBER	(5) FSCM	(6) DESCRIPTION	(7) UNIT OF MEAS	(8) QTY INC IN UNIT
(A) FIG NO.	(B) ITEM NO.					USABLE ON CODE		
4	28	PAHZZ		SA290014W	23880	SOCKET, INTEGRATED CIRCUIT	EA	3
4	29	PAHZZ	962-00-487-7007	N15832N	31295	INTEGRATED CIRCUIT, DTL, NAND GATE	EA	1
						GROUP: 0104 RATIO INPUT ASS EMBLY		
5	1	PAHZZ		24723	39536	PCB, RATIO INPUT	EA	1
5	2	PAHZZ	961-00-931-0372	N3906	34713	TRANSISTOR, SILICON, PNP	EA	1
5	3	PAHZZ		N270	33332	DIODE, GERMANIUM: 80 MA, 100 PIV	EA	2
5	4	PAHZZ	961-00-471-2492	HD1105	33508	DIODE, SILICON: 150 MA	EA	10
5	5	PAHZZ		FF1-81871F	91637	RESISTOR, FILM: 1.87K ohms $\pm 1\%$, 1/8W	EA	1
5	6	PAHZZ	905-00-153-5785	60 S501A	71450	RESISTOR, VARIABLE: 500 ohms $\pm 10\%$, 1W	EA	3
5	7	PAHZZ		FF1-81582F	91637	RESISTOR, FILM: 15.8K ohms $\pm 1\%$, 1/8W	EA	1
5	8	PAHZZ		FF1813R7F	91637	RESISTOR, FILM: 13.7 ohms $\pm 1\%$, 1/8W	EA	1
5	9	PAHZZ		B62G5	01121	RESISTOR, COMPOSITION: 6.2 ohms $\pm 5\%$, 1/4W	EA	1
5	10	PAHZZ		60 S200B	71450	RESISTOR, VARIABLE: 20 ohms $\pm 20\%$, 1/4W	EA	1
5	11	PAHZZ		FF1-828R7F	91637	RESISTOR, FILM: 28.7 ohms $\pm 1\%$, 1/8W	EA	1
5	12	PAHZZ		87623	89536	TRANSISTOR, FIELD EFFECT	EA	1
5	13	PAHZZ		IFF1-82322F	91637	RESISTOR, FILM: 23.2K ohms $\pm 1\%$, 1/8W	EA	2
5	14	PAHZZ	961-00-892-8706	N3904	04713	TRANSISTOR, SILICON, NPN	EA	3
5	15	PAHZZ		IFF1-86041F	91637	RESISTOR, FILM: 6.04K ohms $\pm 1\%$, 1/8W	EA	1
5	16	PAHZZ		IFF1-82261F	91637	RESISTOR, FILM: 3.09K ohms $\pm 1\%$, 1/8W	EA	1
5	17	PAHZZ	905-00-104-8360	B6235	01121	RESISTOR, COMPOSITION: 62K ohms $\pm 5\%$, 1/4W	EA	2
5	18	PAHZZ	905-00-472-6502	B5165	01121	RESISTOR, COMPOSITION: 5.1 ohms $\pm 5\%$, 1/4W	EA	1
5	19	PAHZZ	961-00-888-5468	D333	07263	DIODE, SILICON: 150 MA, 125 PIV	EA	5
5	20	PAHZZ		23865	89536	RESISTOR, BOBBIN, MATCHED SET: R1, R2, R4, R5, R7, R9, R10, R12	SET	1
5	21	PAHZZ		68023	34333	INTEGRATED CIRCUIT, OPNL AMPL	EA	5
5	22	PAHZZ	910-00-716-4950	D15E330J	14655	CAPACITOR, MICA: 33 pF $\pm 5\%$, 500 VDC	EA	7
5	23	PAHZZ	905-00-904-5689	B1535	01121	RESISTOR, COMPOSITION: 15K ohms $\pm 5\%$, 1/4W	EA	1
5	24	PAHZZ		IFF1-86650F	91637	RESISTOR, FILM: 665 ohms $\pm 1\%$, 1/8W	EA	1
5	25	PAHZZ	961-00-931-6137	N4946	07263	TRANSISTOR, SILICON, NPN	EA	2
5	26	PAHZZ		FF1-81821F	91637	RESISTOR, FILM: 1.82K ohms $\pm 1\%$, 1/8W	EA	2
5	27	PAHZZ		FF1-81211F	91637	RESISTOR, FILM: 1.21K ohms $\pm 1\%$, 1/8W	EA	1
5	28	PAHZZ	950-00-175-8660	JD6P	71707	RELAY, COIL	EA	1
5	29	PAHZZ	905-00-156-6478	60 S502A	71450	RESISTOR, VARIABLE: 5K ohms $\pm 10\%$, 1/2W	EA	2
5	30	PAHZZ	962-00-985-1755	M308AH	12040	INTEGRATED CIRCUIT, OPNL AMPL	EA	1
5	31	PAHZZ	962-00-563-1929	M301A	12040	INTEGRATED CIRCUIT, OPNL AMPL	EA	2
5	32	PAHZZ		289850	89536	RELAY, REED SWITCH	EA	2
5	33	PAHZZ	910-00-649-2914	D15F101J	14655	CAPACITOR, MICA: 100 pF $\pm 5\%$, 500 VDC	EA	1
5	34	PAHZZ		B2765	01121	RESISTOR, COMPOSITION: 27Mohms $\pm 5\%$, 1/4W	EA	1
5	35	PAHZZ		280 CFA47	73445	CAPACITOR, PLASTIC: 0.047 uF $\pm 10\%$, 400 VDC	EA	1
5	36	PAHZZ	905-00-911-3753	B4725	01121	RESISTOR, COMPOSITION: 4.7K ohms $\pm 5\%$, 1/4W	EA	1
5	37	PAHZZ		IFF1-81503F	91637	RESISTOR, FILM: 150K ohms $\pm 1\%$, 1/8W	EA	2
5	38	PAHZZ		IFF1-21503F	91637	RESISTOR, FILM: 150K ohms $\pm 1\%$, 1/8W	EA	1

SECTION IV. REPAIR PARTS LIST (CONTINUED)

(1) ILLUSTRATION		(2) SMR CODE	(3) NATIONAL STOCK NUMBER	(4) PART NUMBER	(5) FSCM	(6) DESCRIPTION	(7) UNIT OF MEAS.	(8) QTY INC IN UNIT
(A) FIG NO.	(B) ITEM NO.							
5	39	PAHZZ		R40E0303	77342	RELAY, 4 POLE, DOUBLE THROW	EA	1
5	40	PAHZZ		MFF1-83572F	91637	RESISTOR, FILM: 35.7K ohms +1%, 1/8W	EA	1
5	41	PAHZZ	910-00-459-8641	C280AEA470K	73445	CAPACITOR, PLASTIC: 0.47 uF +10%, 250 VDC	EA	1
5	42	PAHZZ		MFF1-82872F	91637	RESISTOR, FILM: 28.7K ohms +1%, 1/8W	EA	1
5	43	PAHZZ	961-00-402-1995	CD55105	07910	DIODE, SILICON: 75 MA, 90 PIV	EA	2
5	44	PAHZZ		330126	89536	RESISTOR, MATCHED PAIR: R35/R36 and R37/R39 must be replaced in pairs	PR	2
5	45	PAHZZ		MFF1-81002F	91637	RESISTOR, FILM: 10K ohms +1%, 1/8W	EA	4
5	46	PAHZZ		MFF1-82431F	91637	RESISTOR, FILM: 2.43K ohms +1%, 1/8W	EA	1
5	47	PAHZZ		MFF1-84991F	91637	RESISTOR, FILM: 4.99K ohms +1%, 1/8W	EA	2
5	48	PAHZZ	905-00-105-7765	CB2245	01121	RESISTOR, COMPOSITION: 220K ohms +5%, 1/4W	EA	1
5	49	PAHZZ		X463UM105950M	34411	CAPACITOR, PLASTIC: 1.0 uF +10%, 50 VDC	EA	1
5	50	PAHZZ		MFF1-82491F	91637	RESISTOR, FILM: 3.4K ohms +1%, 1/8W	EA	1
5	51	PAHZZ	910-00-816-3142	CD15F391J	14655	CAPACITOR, MICA: 390 pF +5%, 500 VDC	EA	2
5	52	PAHZZ		X463UM1059.50	34411	CAPACITOR, PLASTIC: 2 uF +10%, 50 VDC	EA	1
5	53	PAHZZ	905-00-904-5676	CB1245	01121	RESISTOR, COMPOSITION: 120K ohms +5%, 1/4W	EA	1
5	54	PAHZZ	905-00-904-5677	CB1025	01121	RESISTOR, COMPOSITION: 1K ohm +5%, 1/4W	EA	1
5	55	PAHZZ	950-00-477-1189	U6P	71707	RELAY, COIL	EA	1
5	56	PAHZZ		MFF1-84322F	91637	RESISTOR, FILM: 43.2K ohms +1%, 1/8W	EA	1
GROUP: 0105 LOGIC PCB								
6	1	PAHZZ		290650	89536	REFERENCE AMPLIFIER MATCHED SET: Replace as a set	SET	1
6	2	PAHZZ	905-00-909-3885	CB1035	01121	RESISTOR, COMPOSITION: 10K ohms +5%, 1/4W	EA	3
6	3	PAHZZ	910-00-789-2924	CD15F271J	14655	CAPACITOR, MICA: 270 pF +5%, 500 VDC	EA	1
6	4	PAHZZ		MFF1-83741F	91637	RESISTOR, FILM: 3.74K ohms +1%, 1/8W	EA	1
6	5	PAHZZ	961-00-413-0304	S19254	07263	TRANSISTOR, SILICON, NPN	EA	1
6	6	PAHZZ	961-00-988-7401	1N4817	05277	DIODE, SILICON: 1A, 100 PIV	EA	1
6	7	PAHZZ		MFF1-81823F	91637	RESISTOR, FILM: 182K ohms +1%, 1/8W	EA	1
6	8	PAHZZ	905-00-136-3890	CB5135	01121	RESISTOR, COMPOSITION: 51K ohms +5%, 1/4W	EA	5
6	9	PAHZZ	905-00-989-1969	CB8225	01121	RESISTOR, COMPOSITION: 8.2K ohms +5%, 1/4W	EA	4
6	10	PAHZZ	961-00-892-8706	2N3904	04713	TRANSISTOR, SILICON, NPN	EA	9
6	11	PAHZZ	961-00-931-0372	2N3906	04713	TRANSISTOR, SILICON, PNP	EA	12
6	12	PAHZZ	905-00-105-7765	CB2245	01121	RESISTOR, COMPOSITION: 220K ohms +5%, 1/4W	EA	3
6	13	PAHZZ	905-00-989-3753	CB1135	01121	RESISTOR, COMPOSITION: 11K ohms +5%, 1/4W	EA	6
6	14	PAHZZ	985-00-577-9461	CB2235	01121	RESISTOR, COMPOSITION: 22K ohms +5%, 1/4W	EA	5
6	15	PAHZZ	961-00-471-2492	DHD1105	03508	DIODE, SILICON: 150 MA	EA	5
6	16	PAHZZ	905-00-905-6279	CB1825	01121	RESISTOR, COMPOSITION: 1.8K ohm +5%, 1/4W	EA	2
6	17	PAHZZ		1N270	93332	DIODE, GERMANIUM: 80 MA	EA	2
6	18	PAHZZ	905-00-909-3940	CB2225	01121	RESISTOR, COMPOSITION: 2.2K ohms +5%, 1/4W	EA	2
6	19	PAHZZ	905-00-882-2723	CB2725	01121	RESISTOR, COMPOSITION: 2.7K ohms +5%, 1/4W	EA	2
6	20	PAHZZ	962-00-487-7007	SN15832N	01295	INTEGRATED CIRCUIT, DTL DUAL 4-INPUT NANDGATE	EA	1
6	21	PAHZZ		TSA290014W	23880	SOCKET, INTEGRATED CIRCUIT	EA	3
6	22	PAHZZ		C4312A	18324	INTEGRATED CIRCUIT, TTL, DUAL J-K FLIP-FLOP	EA	5

SECTION IV. REPAIR PARTS LIST (CONTINUED)

(1) ILLUSTRATION		(2) SMR CODE	(3) NATIONAL STOCK NUMBER	(4) PART NUMBER	(5) FSCM	(6) DESCRIPTION	(7) UNI OF MEA	(8) QTY INC IN UNIT
(A) FIG NO.	(B) ITEM NO.							
6	23	PAHZZ		TSA290016W	23880	SOCKET, INTEGRATED CIRCUIT	EA	5
6	24	PAHZZ		C4321A	18324	INTEGRATED CIRCUIT, TTL, DUAL 4-INPUT NOR GATE	EA	1
6	25	PAHZZ		337600	89536	PCB, LOGIC	EA	1
6	26	PAHZZ		MFF1-27503F	91637	RESISTOR, FILM: 750K ohms $\pm 1\%$, 1/2W	EA	1
6	27	PAHZZ		128B101 H253M	56289	CAPACITOR, CERAMIC: 0.025 uF $\pm 20\%$, 100 VDC	EA	1
6	28	PAHZZ	5905-00-911-3753	CB4725	01121	RESISTOR, COMPOSITION: 4.7K ohms $\pm 5\%$, 1/4W	EA	3
6	29	PAHZZ	5910-00-914-2301	BB60181KS3N	71590	CAPACITOR, CERAMIC, 180 pF $\pm 10\%$, 1K VDC	EA	1
6	30	PAHZZ	5905-00-911-3815	CB2735	01121	RESISTOR, COMPOSITION: 27K ohms $\pm 5\%$, 1/4W	EA	1
6	31	PAHZZ	5905-00-904-5677	CB1025	01121	RESISTOR, COMPOSITION: 1K ohm $\pm 5\%$, 1/4W	EA	1
6	32	PAHZZ		CD19F471J	14655	CAPACITOR, MICA: 470 pF $\pm 5\%$, 500 VDC	EA	1
6	33	PAHZZ		CD19F562G	14655	CAPACITOR, MICA: 5600 pF $\pm 2\%$, 500 VDC	EA	1
6	34	PAHZZ		MFF1-84643F	91637	RESISTOR, FILM: 46.4K ohms $\pm 1\%$, 1/8W	EA	1
6	35	PAHZZ		MFF1-81103F	91637	RESISTOR, FILM: 110K ohms $\pm 1\%$, 1/8W	EA	1
6	36	PAHZZ	5905-00-104-8368	CB4705	01121	RESISTOR, COMPOSITION: 370 ohms $\pm 5\%$, 1/4W	EA	1
6	37	PAHZZ		CD19F152J	14655	CAPACITOR, MICA: 1500 pF $\pm 5\%$, 500 VDC	EA	1
6	38	PAHZZ		2N6027	03508	TRANSISTOR, UNIJUNCTION	EA	1
6	39	PAHZZ	5905-00-106-3156	CB1525	01121	RESISTOR, COMPOSITION: 1.5K ohm $\pm 5\%$, 1/4W	EA	7
6	40	PAHZZ	5905-00-918-6522	CB8215	01121	RESISTOR, COMPOSITION: 820 ohms $\pm 5\%$, 1/4W	EA	1
6	41	PAHZZ	5962-00-066-0171	MC846P	04713	INTEGRATED CIRCUIT, DTL, QUAD 2- INPUT NAND GATE	EA	1
6	42	PAHZZ		295337	89536	CONNECTOR, PCB CABLE	EA	1
6	43	PAHZZ	5905-00-135-6046	CB6815	01121	RESISTOR, COMPOSITION: 680 ohms $\pm 5\%$, 1/4W	EA	1
6	44	PAHZZ	5905-00-907-4119	CB3935	01121	RESISTOR, COMPOSITION: 39K ohms $\pm 5\%$, 1/4W	EA	1
6	45	PAHZZ	5905-00-909-3967	CB3335	01121	RESISTOR, COMPOSITION: 33K ohms $\pm 5\%$, 1/4W	EA	1
6	46	PAHZZ	5905-00-960-0126	CB4735	01121	RESISTOR, COMPOSITION: 47K ohms $\pm 5\%$, 1/4W	EA	1
6	47	PAHZZ	5961-00-475-4985	2N1303	01295	TRANSISTOR, GERMANIUM, PNP	EA	1
6	48	PAHZZ	5961-00-985-9077	2N3391	03508	TRANSISTOR, SILICON, NPN	EA	1
6	49	PAHZZ	5910-00-716-4950	CD15E330J	14655	CAPACITOR, MICA: 33 pF $\pm 5\%$, 500 VDC	EA	1
6	50	PAHZZ		275321	89536	RESISTOR, WI REWOUND: 14K ohms $\pm 0.1\%$, 1/4W	EA	1
6	51	PAHZZ		190 PC2008	71450	RESISTOR, VARIABLE: 20 ohms $\pm 20\%$, 1/2W	EA	1
6	52	PAHZZ	5905-00-919-5713	CB1225	01121	RESISTOR, COMPOSITION: 1.2K ohms $\pm 5\%$, 1/4W	EA	1
6	53	PAHZZ	5962-00-563-1929	LM301A	12040	INTEGRATED CIRCUIT, OPNL AMPL	EA	1
6	54	PAHZZ		MFF1-83R743 PORM1PCT	91637	RESISTOR, FILM: 3.74K ohms $\pm 1\%$, 1/8W	EA	1
6	55	PAHZZ	5961-00-908-9666	88000	17069	PAD, TRANSISTOR MOUNTING	EA	2
						GROUP: 0106 A-D CONVERTER ASSEMBLY		
7	1	PAHZZ		329466	89536	PCB, A-D CONVERTER	EA	1
7	2	PAHZZ	5961-00-931-0372	2N3906	04713	TRANSISTOR, SILICON, PNP	EA	2
7	3	PAHZZ	5961-00-892-8706	2N3904	04713	TRANSISTOR, SILICON, NPN	EA	3
7	4	PAHZZ		RS2048	49956	TRANSISTOR, SILICON, PNP	EA	5
7	5	PAHZZ	5905-00-577-9597	CB1545	01121	RESISTOR, COMPOSITION: 150K ohms $\pm 5\%$, 1/4W	EA	1
7	6	PAHZZ		GA3938A	01295	TRANSISTOR, GERMANIUM, PNP	EA	4
7	7	PAHZZ		MFF1-84991F	91637	RESISTOR, FILM: 4.99K ohms $\pm 1\%$, 1/8W	EA	4

SECTION IV. REPAIR PARTS LIST (CONTINUED)

(1) ILLUSTRATION		(2) SMR CODE	(3) NATIONAL STOCK NUMBER	(4) PART NUMBER	(5) FSCM	(6) DESCRIPTION USABLE ON CODE	(7) UNI- OF MEA	(8) QTY INC IN UNIT
(A) FIG NO.	(B) ITEM NO.							
7	8	PAHZZ		MFF1-83242F	91637	RESISTOR, FILM: 32.4K ohms $\pm 1\%$, 1/8W	EA	4
7	9	PAHZZ	5961-00-471-2492	DHD1105	03508	DIODE, SILICON: 150 MA	EA	12
7	10	PAHZZ	5961-00-932-0551	CD36554	07910	DIODE, ZENER: 6.8 VDC	EA	1
7	11	PAHZZ	5905-00-911-3815	CB2735	01121	RESISTOR, COMPOSITION: 27K ohms $\pm 5\%$, 1/4W	EA	3
7	12	PAHZZ	5905-00-959-1202	CB1045	01121	RESISTOR, COMPOSITION: 100K ohms $\pm 5\%$, 1/4W	EA	6
7	13	PAHZZ	5905-00-904-5689	CB1535	01121	RESISTOR, COMPOSITION: 15K ohms $\pm 5\%$, 1/4W	EA	2
7	14	PAHZZ	5910-00-810-4849	C023B101F103M	56289	CAPACITOR, CERAMIC: 0.01 μ F $\pm 20\%$, 100 VDC	EA	5
7	15	PAHZZ		295337	89536	CONNECTOR, PCB CABLE	EA	1
7	16	PAHZZ	5962-00-563-1929	LM301A	12040	INTEGRATED CIRCUIT, OPNL AMPL	EA	4
7	17	PAHZZ	5961-00-402-1979	SPF179	04713	TRANSISTOR, FET, N-CHANNEL	EA	6
7	18	PAHZZ	5910-00-716-4950	CD15E330J	14655	CAPACITOR, MICA: 33 pF $\pm 5\%$, 500 VDC	EA	4
7	19	PAHZZ		863UW47391	84411	CAPACITOR, PLASTIC: 0.047 μ F, $\pm 10\%$, 120 VDC	EA	2
7	20	PAHZZ	5905-00-989-2443	CB2205	01121	RESISTOR, COMPOSITION: 220 ohms $\pm 5\%$, 1/4W	EA	1
7	21	PAHZZ	5905-00-911-3801	CB1835	01121	RESISTOR, COMPOSITION: 18K ohms $\pm 5\%$, 1/4W	EA	1
7	22	PAHZZ	5910-00-459-8641	C280AEA470K	73445	CAPACITOR, PLASTIC: 0.47 μ F $\pm 10\%$, 250 VDC	EA	2
7	23	PAHZZ	5905-00-904-5677	CB1025	01121	RESISTOR, COMPOSITION: 1K ohm $\pm 5\%$, 1/4W	EA	1
7	24	PAHZZ	5961-00-402-1995	CD55105	07910	DIODE, SILICON: 75 MA, 90 PIV	EA	1
7	25	PAHZZ	5961-00-402-1996	CFE13041	07910	TRANSISTOR, FET, N-CHANNEL	EA	6
7	26	PAHZZ	5910-00-816-3142	CD15F391J	14655	CAPACITOR, MICA: 390 pF $\pm 5\%$, 400 VDC	EA	4
7	27	PAHZZ	5905-00-968-6140	CB8245	01121	RESISTOR, COMPOSITION: 820K ohms $\pm 5\%$, 1/4W	EA	1
7	28	PAHZZ	5961-00-402-1979	SPF179	04713	TRANSISTOR, FET, N-CHANNEL, CODE A	EA	1
						OR		
7	28	PAHZZ		U2412	15818	TRANSISTOR, FET, N-CHANNEL, CODE B	EA	1
7	29	PAHZZ	5961-00-144-2468	DN423	17856	TRANSISTOR, FET, DUAL N-CHANNEL	EA	1
7	30	PAHZZ	5961-00-402-2014	DN503	17856	TRANSISTOR, FET, DUAL N-CHANNEL	EA	1
7	31	PAHZZ	5905-00-105-7765	CB2245	01121	RESISTOR, COMPOSITION: 220K ohms $\pm 5\%$, 1/4W	EA	3
7	32	PAHZZ		274795	89536	TRANSISTOR, MATCHED SET: Must be replaced as a set	SET	1
7	33	PAHZZ	5905-00-994-6676	EB1065	01121	RESISTOR, COMPOSITION: 1.0 ohm $\pm 5\%$, 1/2W	EA	1
7	35	PAHZZ	5905-00-911-3753	CB4725	01121	RESISTOR, COMPOSITION: 4.7K ohms $\pm 5\%$, 1/4W	EA	3
7	36	PAHZZ	5905-00-960-0126	CB4735	01121	RESISTOR, COMPOSITION: 47K ohms $\pm 5\%$, 1/4W	EA	2
7	37	PAHZZ		285239	89536	RESISTOR, WIREWOUND, MATCHED SET: must be replaced as set	SET	1
7	38	PAHZZ	5905-00-119-3505	CB6835	01121	RESISTOR, COMPOSITION: 68K ohms $\pm 5\%$, 1/4W	EA	1
7	39	PAHZZ	5905-00-683-2240	CB2215	01121	RESISTOR, COMPOSITION: 220 ohms $\pm 5\%$, 1/4W	EA	1
7	40	PAHZZ		291690	89536	RESISTOR, WIREWOUND, MATCHED SET: must be replaced as set	SET	1
7	41	PAHZZ		MFF1-84532F	91637	RESISTOR, FILM: 45.3K ohms $\pm 1\%$, 1/8W	EA	3
7	42	PAHZZ	5905-00-909-3885	CB1035	01121	RESISTOR, COMPOSITION: 10K ohms $\pm 5\%$, 1/4W	EA	4
7	43	PAHZZ		MFF1-84992I	91637	RESISTOR, FILM: 49.9K ohms $\pm 1\%$, 1/8W	EA	1
7	44	PAHZZ	5961-00-888-5468	FD333	07263	DIODE, SILICON: 150 MA, 125 PIV	EA	3
7	45	PAHZZ		U2412	15818	TRANSISTOR, FET, N-CHANNEL	EA	7
7	46	PAHZZ		190PC200B	71450	RESISTOR, VARIABLE: 20 ohms $\pm 20\%$, 1/2W	EA	3
7	47	PAHZZ		1N270	93332	DIODE, GERMANIUM: 80 MA, 100 PIV	EA	1
7	48	PAHZZ	5985-00-577-9461	CB2235	01121	RESISTOR, COMPOSITION: 22K ohms $\pm 5\%$, 1/4W	EA	2
7	49	PAHZZ	5905-00-909-3967	CB3335	01121	RESISTOR, COMPOSITION: 33K ohms $\pm 5\%$, 1/4W	EA	2

SECTION IV. REPAIR PARTS LIST (CONTINUED)

(1) ILLUSTRATION		(2) SMR CODE	(3) NATIONAL STOCK NUMBER	(4) PART NUMBER	(5) FSC	(6) DESCRIPTION	(7) UNI- OF MEA	(8) QTY INC IN UNIT
(A) FIG NO	(B) ITEM NO					USABLE CI CODE		
7	50	PAHZZ	905-00-741-0744	CB5625	01121	RESISTOR, COMPOSITION: 5.6K ohms $\pm 5\%$, 1/4W	EA	1
7	51	PAHZZ		MFF1-82212F	91637	RESISTOR, FILM: 22.1K ohms $\pm 1\%$, 1/8W	EA	1
7	52	PAHZZ		190C201B	71450	RESISTOR, VARIABLE: 200 ohms $\pm 20\%$, 1/2W	EA	1
7	53	PAHZZ		288647	89536	RESISTOR, WI REWOUND: 5K ohms $\pm 0.05\%$, 1/4W	EA	1
7	54	PAHZZ		MFF1-816R9F	91637	RESISTOR, FILM: 16.9 ohms $\pm 1\%$, 1/8W	EA	1
7	55	PAHZZ		360S200B	71450	RESISTOR, VARIABLE: 20 ohms $\pm 20\%$, 1.0W	EA	1
7	56	PAHZZ		288654	89536	RESISTOR, WI REWOUND: 1.022K ohms $\pm 0.05\%$, 1/4W	EA	1
7	57	PAHZZ		CLIN150	00656	CAPACITOR, CERAMIC: 15 pF $\pm 10\%$, 500 VDC	EA	1
7	58	PAHZZ	905-00-156-6459	360 S103A	71450	RESISTOR, VARIABLE: 10K ohms $\pm 10\%$, 1.0W	EA	1
7	59	PAHZZ		321398	89536	TRANSISTOR, SILICON, PNP	EA	1
7	60	PAHZZ		MFF1-86041F	91637	RESISTOR, FILM: 6.04K ohms $\pm 1\%$, 1/8W	EA	1
7	61	PAHZZ		MFF1-81001F	91637	RESISTOR, FILM: 1K ohm $\pm 1\%$, 1/8W	EA	1
7	62	PAHZZ	910-00-080-5377	C280AEA47K	73445	CAPACITOR, PLASTIC: 0.047 uF $\pm 10\%$, 250 VDC	EA	1
7	63	PAHZZ	905-00-402-4258	CB6255	01121	RESISTOR, COMPOSITION: 6.2M ohms $\pm 5\%$, 1/4W	EA	2
7	64	PAHZZ		GA3937A	01295	TRANSISTOR, GERMANIUM, NPN	EA	4
7	65	PAHZZ	905-00-153-5734	360 S500A	71450	RESISTOR, VARIABLE: 50 ohms $\pm 10\%$, 1.0W	EA	1
7	66	PAHZZ		MFF1-87503F	91637	RESISTOR, FILM: 750K ohms $\pm 1\%$, 1/8W	EA	2
7	67	PAHZZ	905-00-153-5730	360S101A	71450	RESISTOR, VARIABLE: 100 ohms $\pm 10\%$, 1.0W	EA	1
7	68	PAHZZ		MFF1-41R55F	91637	RESISTOR, FILM: 1.5M ohms $\pm 1\%$, 1/4W	EA	1
7	69	PAHZZ	905-00-960-0207	CB3055	01121	RESISTOR, COMPOSITION: 3M ohms $\pm 5\%$, 1/4W	EA	1
7	70	PAHZZ		QD10178E	11726	TRANSISTOR, SILICON, NPN	EA	1
7	71	PAHZZ	905-00-153-6180	360S201A	71450	RESISTOR, VARIABLE: 200 ohms $\pm 10\%$, 1.0W	EA	1
7	72	PAHZZ	905-00-055-7051	CB5145	01121	RESISTOR, COMPOSITION: 510K ohms $\pm 5\%$, 1/4W	EA	1
7	73	PAHZZ	961-00-908-9666	88000	17069	PAD, TRANSISTOR MOUNTING	EA	8
7	74	PAHZZ		MFF1-22152F	91637	RESISTOR, FILM: 21.5K ohms $\pm 1\%$, 1/8W	EA	1
GROUP: 0107 ACTIVE FILTER ASSEMBLY								
8	1	PAHZZ		337626	89536	PCB, ACTIVE FILTER	EA	1
8	2	PAHZZ		863 UWR470120V PORM20PCT	84411	CAPACITOR, PLASTIC: 0.47 uF $\pm 20\%$, 120 VDC	EA	4
8	3	PAHZZ		MFF1-84643F	91637	RESISTOR, FILM: 46.4K ohms $\pm 1\%$, 1/8W	EA	4
8	4	PAHZZ	962-00-563-1929	LM301A	12040	INTEGRATED CIRCUIT, OPNL AMPL	EA	2
8	5	PAHZZ		MFF1-81003F	91637	RESISTOR, FILM: 100K ohms $\pm 1\%$, 1/8W	EA	1
8	6	PAHZZ	910-00-716-4950	CD15E330J	14655	CAPACITOR, MICA: 33 pF $\pm 5\%$, 500 VDC	EA	2
8	7	PAHZZ		QD20078	11726	TRANSISTOR, SILICON, NPN	EA	1
8	8	PAHZZ	961-00-617-4750	CD12599	07910	DIODE, SILICON: 10 MA, 2 PIV	EA	2
8	9	PAHZZ	961-00-892-8706	2N3904	04713	TRANSISTOR, SILICON, NPN	EA	1
8	10	PAHZZ		MFF1-81403F	91637	RESISTOR, FILM: 140K ohms $\pm 1\%$, 1/8W	EA	1
8	11	PAHZZ		CD15F151J	14655	CAPACITOR, MICA: 150 pF $\pm 5\%$, 200 VDC	EA	2
8	12	PAHZZ		MFF1-87151F	91637	RESISTOR, FILM: 7.15K ohms $\pm 1\%$, 1/8W	EA	1
8	13	PAHZZ		MFF1-82001F	91637	RESISTOR, FILM: 2K ohms $\pm 1\%$, 1/8W	EA	1
8	14	PAHZZ	961-00-931-0372	2N3906	04713	TRANSISTOR, SILICON, PNP	EA	1
8	15	PAHZZ		MFF1-82153F	91637	RESISTOR, FILM: 215K ohms $\pm 1\%$, 1/8W	EA	2

SECTION IV. REPAIR PARTS LIST (CONTINUED)

(1) ILLUSTRATION		(2) SMR CODE	(3) NATIONAL STOCK NUMBER	(4) PART NUMBER	(5) FSCM	(6) DESCRIPTION	(7) UNI- OF MEA	(8) QTY INC IN UNIT
(A) FIG NO.	(B) ITEM NO.							
8	16	PAHZZ	5905-00-449-0007	190PC502B	71450	RESISTOR, VARIABLE: 5K ohms $\pm 20\%$, 1/2W	EA	1
8	17	PAHZZ		RN60XXXXF	81349	RESISTOR, FILM, SELECTED	EA	2
8	18	PAHZZ		MFF1-82491F	91637	RESISTOR, FILM: 2.49K ohms $\pm 1\%$, 1/8W	EA	1
8	19	PAHZZ		MFF1-88252F	91637	RESISTOR, FILM: 82.5K ohms $\pm 1\%$, 1/8W	EA	1
8	20	PAHZZ	5905-00-959-1202	CB1045	01121	RESISTOR, COMPOSITION: 100K ohm $\pm 5\%$, 1/4W	EA	1
8	21	PAHZZ		MFF1-88661F	91637	RESISTOR, FILM: 8.66K ohms $\pm 1\%$, 1/8W	EA	1
8	22	PAHZZ	5961-00-471-2492	DHD1105	03508	DIODE, SILICON: 150 MA	EA	1
8	23	PAHZZ	5950-00-175-8660	UD6P	71707	RELAY, COIL	EA	1
8	24	PAHZZ	5930-00-439-0687	765972	15898	RELAY, REED SWITCH	EA	2
8	25	PAHZZ	5905-00-110-7622	CB6825	01121	RESISTOR, COMPOSITION: 6.8K ohms $\pm 5\%$, 1/4W	EA	1
						GROUP: 0108 BUFFER ASSEMBLY		
9	1	PAHZZ		327148	89536	PCB, BUFFER	EA	1
9	2	PAHZZ	5905-00-116-8554	CB1055	01121	RESISTOR, COMPOSITION: 1M ohm $\pm 5\%$, 1/4W	EA	1
9	3	PAHZZ		R40E0303	77342	RELAY, 4-POLE DOUBLE THROW: 5 VDC COIL	EA	1
9	4	PAHZZ	5905-00-279-2281	HB9145	01121	RESISTOR, COMPOSITION: 910K ohms $\pm 5\%$, 2W	EA	1
9	5	PAHZZ	5961-00-471-2492	DHD1105	03508	DIODE, GERMANIUM: 80 MA, 100 PIV	EA	5
9	6	PAHZZ	5950-00-477-1189	U6P	71707	COIL, RELAY	EA	3
9	7	PAHZZ	5950-00-175-8660	UD6P	71707	COIL, RELAY	EA	1
9	8	PAHZZ		TYPE MRR5	12617	RELAY, REED SWITCH	EA	2
9	9	PAHZZ	5961-00-892-0734	1N456A	93332	DIODE, SILICON: 200 MA, 25 PIV	EA	5
9	10	PAHZZ	5905-00-909-3885	CB1035	01121	RESISTOR, COMPOSITION: 10K ohms $\pm 5\%$, 1/4W	EA	2
9	11	PAHZZ		RN60XXXXF	81349	RESISTOR, FILM, SELECTED	EA	2
9	12	PAHZZ		284505	89536	RESISTOR, WI REWOUND, MATCHED SET: Replace as a set	SET	1
9	13	PAHZZ	5905-00-126-6683	CB3325	01121	RESISTOR, COMPOSITION: 3.3K ohms $\pm 5\%$, 1/4W	EA	1
9	14	PAHZZ	5962-00-252-4927	LM308H	12040	INTEGRATED CIRCUIT, OPNL AMPL	EA	1
9	15	PAHZZ		321638	89536	TRANSISTOR, SILICON, PNP	EA	1
9	16	PAHZZ	5905-00-156-6459	36 0S103A	71450	RESISTOR, VARIABLE: 10K ohms $\pm 10\%$, 1W	EA	1
9	17	PAHZZ	5910-00-789-2924	CD15F27 1J	14655	CAPACITOR, MICA: 270 pF $\pm 5\%$, 500 VDC	EA	1
9	18	PAHZZ	5905-00-553-9318	EB1071	01121	RESISTOR, COMPOSITION: 100M ohms $\pm 10\%$, 1/2W	EA	2
9	19	PAHZZ		1N270	93332	DIODE, GERMANIUM: 80 mA	EA	2
9	20	PAHZZ		CD19F222J	14655	CAPACITOR, MICA: 2200 pF $\pm 5\%$, 500 VDC	EA	1
9	21	PAHZZ		190PC102B	71450	RESISTOR, VARIABLE: 1K ohm $\pm 20\%$, 1/2W	EA	1
9	22	PAHZZ	5905-00-169-3864	190PC101B	71450	RESISTOR, VARIABLE: 100 ohms $\pm 20\%$, 1/2W	EA	1
9	23	PAHZZ		190PC104B	71450	RESISTOR, VARIABLE: 100K ohms $\pm 20\%$, 1/2W	EA	1
9	24	PAHZZ	5905-00-994-6676	EB1065	01121	RESISTOR, COMPOSITION: 1.0 ohm $\pm 5\%$, 1/2W	EA	1
9	25	PAHZZ	5940-00-463-7270	FTE12	98291	TERMINAL, FEEDTHROUGH	EA	8
9	26	PAHZZ		MFF1-21001F	91637	RESISTOR, FILM: 1K ohm $\pm 1\%$, 1/2W	EA	1
9	27	PAHZZ	5961-00-931-0372	2N3906	04713	TRANSISTOR, SILICON, PNP	EA	2
9	28	PAHZZ	5905-00-909-3885	CB1035	01121	RESISTOR, COMPOSITION: 10K ohms $\pm 5\%$, 1/4W	EA	1
9	29	PAHZZ		MFF1-84422F	91637	RESISTOR, FILM: 60.4K ohms $\pm 1\%$, 1/8W	EA	1
9	30	PAHZZ		MFF1-81002F	91637	RESISTOR, FILM: 10K ohms $\pm 1\%$, 1/8W	EA	1

SECTION IV. REPAIR PART LIST (CONTINUED)

(1) ILLUSTRATION		(2) SMR CODE	(3) NATIONAL STOCK NUMBER	(4) PART NUMBER	(5) FSCM	(6) DESCRIPTION	(7) UNIT OF MEA	(8) QTY INC IN UNIT
(A) FIG NO.	(B) ITEM NO					USABLE CN CODE		
9	31	PAHZZ		4F11-81372F	31637	RESISTOR, FILM: 13.7K ohms $\pm 1\%$, 1/8W	EA	1
9	32	PAHZZ		4FF1-82492F	31637	RESISTOR, FILM: 34K ohms $\pm 1\%$, 1/8W	EA	1
9	33	PAHZZ		4FF1-81911F	31637	RESISTOR, FILM: 2.61K ohms $\pm 1\%$, 1/8W	EA	1
9	34	PAHZZ		4FF1-81003F	31637	RESISTOR, FILM: 100K ohms $\pm 1\%$, 1/8W	EA	1
9	35	PAHZZ		298893	39536	COVER, BUFFER	EA	1
9	36	PAHZZ		4FF1-82320F	31637	RESISTOR, FILM: 232 ohms $\pm 5\%$, 1/8W	EA	1
9	37	PAHZZ	961-00-731-1235	2N1307	01295	TRANSISTOR, GERMANIUM, PNP	EA	1
9	38	PAHZZ		2D20078	11726	TRANSISTOR, SILICON, NPN	EA	1
9	39	PAHZZ		4121-23R834F	00327	RESISTOR, FILM: 3.83M ohms $\pm 1\%$, 1/2W	EA	1
9	40	PAHZZ	961-00-413-0304	519254	07263	TRANSISTOR, SILICON, NPN	EA	1
9	41	PAHZZ	961-00-617-4750	CD12599	07910	DIODE, SILICON: 10 mA, 2 PIV	EA	1
9	42	PAHZZ	961-00-908-9666	38000	17069	PAD, TRANSISTOR MOUNTING	EA	2
9	43	PAHZZ		2D10178E	11726	TRANSISTOR, SILICON, NPN	EA	1
9	44	PAHZZ	910-00-649-2914	CD15F101J	14655	CAPACITOR, MICA: 100 pF $\pm 5\%$, 500 VDC	EA	2
9	45	PAHZZ		290320	89536	RESISTOR, MATCHED SET: Replace as a set	SET	1
9	46	PAHZZ	910-00-716-4950	CD15E330J	14655	CAPACITOR, MICA: 33 pF $\pm 5\%$, 500 VDC	EA	1
9	47	PAHZZ	910-00-577-3281	55C23A1	56289	CAPACITOR, CERAMIC: 0.05 uF $\pm 20\%$, 100 VDC	EA	2
9	48	PAHZZ	962-00-985-1512	LM310H	12040	INTEGRATED CIRCUIT, VOLTAGE FOLLOWER	EA	1
9	49	PAHZZ		1N754	07910	DIODE, ZENER: 6.8 VDC	EA	1
9	50	PAHZZ	961-00-142-8925	S37234	07263	TRANSISTOR, SILICON, PNP	EA	1
9	51	PAHZZ	905-00-904-5677	CB1025	01121	RESISTOR, COMPOSITION: 1K ohm $\pm 5\%$, 1/4W	EA	1
9	52	PAHZZ	905-00-909-3965	C83315	01121	RESISTOR, COMPOSITION: 330 ohms $\pm 5\%$, 1/4W	EA	1
9	53	PAHZZ	962-00-184-8205	MC858P	04713	INTEGRATED CIRCUIT, NAND GATE	EA	1
9	54	PAHZZ		TSA290014W	23880	SOCKET, INTEGRATED CIRCUIT	EA	1
9	55	PAHZZ	905-00-413-2605	GB4735	01121	RESISTOR, COMPOSITION: 47K ohms $\pm 5\%$, 1/2W	EA	1
9	56	PAHZZ		325043	89536	CABLE ASSEMBLY, BUFFER	EA	1
9	57	PAHZZ		SL841777	12615	TERMINALS, FEEDTHROUGH	EA	11
9	58	PAHZZ		289850	89536	RELAY, REED SWITCH	EA	2
						GROUP: 0109 FINAL ASSEMBLY		
10	1	PAHZZ		324962	89536	FRONT PANEL ASS EMBLY	EA	1
10	2	PAHZZ	3355-00-449-3096	158956	89536	KNOB, POINTER	EA	1
10	3	PAHZZ	3355-00-242-9535	190249	89536	KNOB	EA	2
10	4	PAHZZ		324970	89536	REAR PANEL ASSEMBLY	EA	1
10	5	PAHZZ		326538	89536	TRANSFORMER, POWER	EA	1
10	6	PAHZZ		324946	89536	CABLE, REAR INPUT	EA	1
10	7	PAHZZ		326181	89536	RESISTOR, VARIABLE, WI REWOUND: 10K ohms $\pm 10\%$, 1-1/2W	EA	1
10	8	PAHZZ		326199	89536	RESISTOR, VARIABLE, WI REWOUND: 5K ohms $\pm 10\%$, 1-1/2W	EA	1
10	9	PAHZZ		324210	89536	CHASSIS ASSEMBLY, GUARD	EA	1
10	10	PAHZZ		324715	89536	CHASSIS, GUARD	EA	1
10	11	PAHZZ		297937	89536	SHIELD, A-D	EA	2
10	12	PAHZZ		324707	89536	SUPPORT, REAR R.H.	EA	1
10	13	PAHZZ		297754	89536	SHIELD, DOU11, LEFT	EA	1

SECTION IV. REPAIR PARTS LIST (CONTINUED)

(1) UNIT (A) FIG NO.	TION (B) TEM NO.	(2) SMR CODE	(3) NATIONAL STOCK NUMBER	(4) PART NUMBER	(5) FSCM	(6) DESCRIPTION	(7) UNIT OF EAS	(8) QUANTITY IN UNIT
10	14	PAHZZ		297705	89536	SHIELD, DOU II, RIGHT	EA	1
10	15	PAHZZ		324699	89536	SUPPORT, CARD GUIDE	EA	1
10	16	PAHZZ		298885	89536	MOUNT, DISPLAY PCB	EA	4
10	17	PAHZZ		297747	89536	FRAME, REAR, LEFT	EA	1
10	18	PAHZZ		324178	89536	GUSSET, GUARD	EA	1
10	19	PAHZZ		301481	89536	BUFFER, SHIELD	EA	1
10	20	PAHZZ		324202	89536	INSULATOR, GUARD, REAR	EA	2
10	21	PAHZZ		298836	89536	GUIDE, CARD	EA	123
10	22	PAHZZ		324228	89536	SHELL ASSEMBLY	EA	1
10	23	PAHZZ		324756	89536	DISPLAY ASSEMBLY	EA	1
10	24	PAHZZ		324798	89536	FUNCTION DISPLAY ASSEMBLY	EA	1
10	25	PAHZZ		324194	89536	MASK	EA	1
10	26	PAHZZ		298810	89536	FRAME	EA	1
10	27	PAHZZ		858635C	00779	RECEPTACLE	EA	10
10	28	PAHZZ	1240-00-183-0658	210	17537	LAMP, INCANDESCENT	EA	7
10	29	PAHZZ		298919	89536	PCB, FUNCTION DISPLAY	EA	1
10	10	PAHZZ		324806	89536	DECIMAL LOGIC ASSEMBLY	EA	1
10	11	PAHZZ		297846	89536	INSULATOR, TERMINAL STRIP	EA	6
10	12	PAHZZ		301382	89536	TERMINAL	EA	4
10	13	PAHZZ		301390	89536	TERMINAL	EA	5
10	14	PAHZZ		311597	89536	JUMPER, RESISTOR	EA	1
10	15	PAHZZ		326322	89536	GUARD, INSULATOR	EA	2
10	16	PAHZZ		324020	89536	SHIELD, SWITCH	EA	1
10	17	PAHZZ		324079	89536	GUARD, FRONT PANEL	EA	1
10	18	PAHZZ		307298	89536	RESISTOR, WIREBOUND: 50K ohm $\pm 25\%$	EA	2
						GROUP: 0110 FRONT PANEL ASSEMBLY		
11	1	PAHZZ		323980	89536	PANEL, FRONT	EA	1
11	2	PAHZZ		326330	89536	PANEL, FRONT, OVERLAY	EA	1
11	3	PAHZZ		7001	05704	BUSHING	EA	3
11	4	PAHZZ		324186	89536	WINDOW, FRONT PANEL	EA	1
11	5	PAHZZ	730-00-013-1073	320283	89536	SWITCH ASSEMBLY	EA	2
11	6	PAHZZ		324053	89536	RETAINER, SWITCH	EA	2
11	7	PAHZZ		MS3505922	96906	SWITCH, TOGGLE	EA	1
11	8	PAHZZ	930-00-539-7013	N1030B	97539	SEAL, SWITCH	EA	1
11	9	PAHZZ		109317	88245	HANDLE	EA	2
11	10	PAHZZ		82065	32767	BINDING POST, RED	EA	1
11	11	PAHZZ		21040600	78189	LUG, SOLDER	EA	3
11	12	PAHZZ		82045	32767	BINDING POST, BLACK	EA	1
11	13	PAHZZ		82055	32767	BINDING POST, BLUE	EA	1
11	14	PAHZZ		09389751	24655	SHORTING LINK	EA	1
11	15	PAHZZ		327130	89536	INSULATOR, BINDING POST	EA	1

SECTION IV. REPAIR PARTS LIST (CONTINUED)

(1) LUSTRATION		(2) SMR CODE	(3) NATIONAL STOCK NUMBER	(4) PART NUMBER	(5) FSCM	(6) DESCRIPTION	(7) UNIT OF MEAS	(8) QTY INC IN UNIT
(A) FIG NO.	(B) ITEM NO.							
11	16	PAHZZ	5905-00-072-0647	EB1961	01121	RESISTOR, COMPOSITION: 10M ohms +10%, 1/2W	EA	1
11	17	PAHZZ		HVD347FORM1 OPCT	56289	CA PACITOR, CERAMIC: 47 PF +10%, 2K VDC GROUP: 0111 REAR PANEL ASSEMBLY	EA	1
12	1	PAHZZ	5920-00-280-8344	F02A250V1 -2A	81349	FUSE, FAST ACTING: 1/2A, 250 V	EA	1
12	2	PAHZZ		FHN26G1	71400	FUSEHOLDER	EA	1
12	3	PAHZZ	5940-00-729-2448	1061	91886	LUG, SOLDER	EA	1
12	4	PAHZZ		82065	32767	BINDING POST, RED	EA	2
12	5	PAHZZ		82045	32767	BINDING POST, BLACK	EA	2
12	6	PAHZZ		82055	32767	BINDING POST, BLUE	EA	2
12	7	PAHZZ		21 040600	78189	LUG, SOLDER	EA	6
12	8	PAHZZ		973102 A10SLOS3PG39	02660	CONNECTOR, MALE, BOX RECEPTACLE	EA	1
12	9	PAHZZ		306241	ZZZZZ	GASKET, CONNECTOR	EA	1
12	10	PAHZZ	5975-00-906-2414	SSC2	06383	CLAMP, CABLE	EA	1
12	11	PAHZZ		325019	89536	CABLE ASSEMBLY, PRINTER OUTPUT	EA	1
12	12	PAHZZ		MS3102R3610S	81349	CONNECTOR, MALE, BOX RECEPTACLE	EA	1
12	13	PAHZZ		324749	89536	PCE, PRINTER OUTPUT	EA	1
12	14	PAHZZ		104045036S	83298	GASKET, CONNECTOR	EA	2
12	15	PAHZZ		109317	88245	HANDLE, CARRY	EA	2
12	16	PAHZZ		323998	89536	PANEL, REAR	EA	1
12	17	PAHZZ		324988	89536	CABLE ASSEMBLY, POWER GROUP: 0112 DISPLAY ASSEMBLY	EA	1
13	1	PAHZZ		329458	89536	PCE, DISPLAY	EA	1
13	2	PAHZZ	5961-00-471-2492	DHD1105	03508	DIODE, SILICON: 150 mA	EA	11
13	3	PAHZZ	5905-00-904-5677	CB1025	01121	RESISTOR, COMPOSITION: 1K OHM +5%, 1/4W	EA	1
13	4	PAHZZ	5905-00-989-7943	CB1235	01121	RESISTOR, COMPOSITION: 12K OHMS +5%, 1/4W	EA	2
13	5	PAHZZ	5905-00-916-7267	CB8235	01121	RESISTOR, COMPOSITION: 82K OHMS	EA	2
13	6	PAHZZ		2N6027	03508	TRANSISTOR, SILICON, UNIJUNCTION	EA	2
13	7	PAHZZ		1N270	93332	DIODE, GERMANIUM: 80 mA, 100 PIV	EA	13
13	8	PAHZZ		583652	00779	CONNECTOR, FEMALE, 12 CONTACT	EA	2
13	9	PAHZZ	5905-00-909-3940	CB2225	01121	RESISTOR, COMPOSITION: 2.2K OHMS +5%, 1/4W	EA	2
13	10	PAHZZ		2N3904	04713	TRANSISTOR, SILICON, NPN	EA	8
13	11	PAHZZ		5836509	00779	CONNECTOR, FEMALE, 24 CONTACT	EA	7
13	12	PAHZZ		J2412	15818	TRANSISTOR, PGT, N-CHANNEL	EA	2
13	13	PAHZZ		284240	39536	CONNECTOR, FEMALE, 24 CONTACT: 6 TERMINALS REMOVED	EA	3
13	14	PAHZZ	5961-00-400-4545	60994	95303	TRANSISTOR, SILICON, NPN	EA	3
13	15	PAHZZ	5905-00-919-5713	CB1225	01121	RESISTOR, COMPOSITION: 1.2K OHMS +5%, 1/4W	EA	3
13	16	PAHZZ	5905-00-882-2723	CB2725	01121	RESISTOR, COMPOSITION: 2.7K OHMS +5%, 1/4W	EA	3
13	17	PAHZZ		3N7416P	01295	INTEGRATED CIRCUIT, BUFFER DRIVER	EA	1
13	18	PAHZZ		583257	00779	SOCKET, INTEGRATED CIRCUIT	EA	1
13	19	PAHZZ		7128 101H253M	56289	CAPACITOR, CERAMIC: 0.025 uF +20%, 100 VDC	EA	1

SECTION IV. REPAIR PARTS LIST (CONTINUED)

(1) ILLUSTRATION		(2) SMR CODE	(3) NATIONAL STOCK NUMBER	(4) PART NUMBER	(5) FSC	(6) DESCRIPTION	(7) UNIT OF MEAS	(8) QTY INC IN UNIT
(A) FIG NO.	(B) ITEM NO.							
13	20	PAHZZ	5905-00-909-3885	CB1035	01121	RESISTOR, COMPOSITION: 10K ohms $\pm 5\%$, 1/4W	EA	11
13	21	PAHZZ	5961-00-931-0152	2N3391	0350E	TRANSISTOR, SILICON, NPN	EA	1
13	22	PAHZZ	5910-00-577-3281	55C23A1	5628S	CAPACITOR, CERAMIC: 0.05 μ F $\pm 20\%$, 100 VDC	EA	1
13	23	PAHZZ	5905-00-110-7622	CB6825	01121	RESISTOR, COMPOSITION: 6.8K ohms $\pm 5\%$, 1/4W	EA	1
13	24	PAHZZ	5905-00-577-9494	CB4715	01121	RESISTOR, COMPOSITION: 470 ohms $\pm 5\%$, 1/4W	EA	1
13	25	PAHZZ	5961-00-931-0372	2N3906	04713	TRANSISTOR, SILICON, PNP	EA	2
13	26	PAHZZ		325035	8953E	SWITCH ASSEMBLY	EA	1
13	27	PAHZZ		297820	8953E	BRACKET, SWITCH	EA	2
13	28	PAHZZ		325985	8953E	SUBASSEMBLY, SWITCH	EA	1
13	29	PAHZZ		JC4284	7159C	SPACER, DOG	EA	5
13	30	PAHZZ		325977	8953E	SUBASSEMBLY, SWITCH	EA	1
13	31	PAHZZ		325050	8953E	CABLE, SWITCH	EA	1
13	32	PAHZZ	5910-00-810-4849	C023B101F103M	5628S	CAPACITOR, CERAMIC: 0.01 μ F $\pm 20\%$, 100 VDC	EA	1
13	33	PAHZZ		C4312A	18324	INTEGRATED CIRCUIT, FLIP-FLOP	EA	2
13	34	PAHZZ		583529	0077S	SOCKET, INTEGRATED CIRCUIT	EA	3
13	35	PAHZZ	5910-00-110-7493	C023B101E502M	5628S	CAPACITOR, CERAMIC: 0.005 μ F $\pm 20\%$, 100 VDC	EA	1
13	36	PAHZZ	5905-00-989-1969	CB8225	01121	RESISTOR, COMPOSITION: 8.2K ohms $\pm 5\%$, 1/4W	EA	7
13	37	PAHZZ	5962-00-476-8358	DM8840M	1204C	INTEGRATED CIRCUIT, DECODER DRIVER	EA	1
13	38	PAHZZ	5915-00-498-6059	CB3905	01121	RESISTOR, COMPOSITION: 390 ohms $\pm 5\%$, 1/4W	EA	7
13	39	PAHZZ		B5853ST	83594	TUBE, NEON READOUT	EA	6
13	40	PAHZZ	5961-00-890-0662	2N4888	0726:	TRANSISTOR, SILICON, PNP	EA	5
13	41	PAHZZ	5905-00-918-6522	CB8215	01121	RESISTOR, COMPOSITION: 820 ohms $\pm 5\%$, 1/4W	EA	1
13	42	PAHZZ		S24496	0726:	TRANSISTOR, SILICON, NPN	EA	4
13	43	PAHZZ	5905-00-909-3965	CB3315	01121	RESISTOR, COMPOSITION: 330 ohms $\pm 5\%$, 1/4W	EA	1
13	44	PAHZZ	5905-00-766-9392	CB4315	01121	RESISTOR, COMPOSITION: 430 ohms $\pm 5\%$, 1/4W	EA	1
13	45	PAHZZ		B5856ST	83594	TUBE, POLARITY INDICATOR	EA	1
13	46	PAHZZ	5905-00-683-2236	CB3915	01121	RESISTOR, COMPOSITION: 390 ohms $\pm 5\%$, 1/4W	EA	3
13	47	PAHZZ	5905-00-141-0743	CB3925	01121	RESISTOR, COMPOSITION: 3.9K ohms $\pm 5\%$, 1/4W	EA	4
13	48	PAHZZ	5905-00-905-6278	CB1635	01121	RESISTOR, COMPOSITION: 16K ohms $\pm 5\%$, 1/4W	EA	2
13	49	PAHZZ	5905-00-911-3753	CB4725	01121	RESISTOR, COMPOSITION: 4.7K ohms $\pm 5\%$, 1/4W	EA	1
13	50	PAHZZ	5905-00-905-6279	CB1825	01121	RESISTOR, COMPOSITION: 1.8K ohms $\pm 5\%$, 1/4W	EA	1
13	51	PAHZZ		45154PORM20PCT2	01450	RESISTOR, VARIABLE: 150K ohms $\pm 20\%$, 2W	EA	1
13	52	PAHZZ	5905-00-113-4860	CB2705	01121	RESISTOR, COMPOSITION: 270 ohms $\pm 5\%$, 1/4W	EA	1
13	53	PAHZZ	5910-00-828-1133	C426ARE20	03445	CAPACITOR, ELECTROLYTIC: 20 μ F $\pm 50\%$, 16 VDC	EA	1
13	54	PAHZZ	5910-00-988-4344	BB60301KW7W	01590	CAPACITOR, CERAMIC: 300 pF $\pm 10\%$, 500 VDC	EA	1
13	55	PAHZZ	5905-00-916-7268	CB7535	01121	RESISTOR, COMPOSITION: 75K ohms $\pm 5\%$, 1/4W	EA	1
13	56	PAHZZ	5905-00-909-3967	CB3335	01121	RESISTOR, COMPOSITION: 33K ohms $\pm 5\%$, 1/4W	EA	1
13	57	PAHZZ	5961-00-908-9666	88000	07069	PAD, TRANSISTOR, MOUNTING	EA	10
13	58	PAHZZ		86144-2	00779	PIN, CONNECTOR	EA	10
13	59	PAHZZ		293498	09536	INSERT, POLARITY	EA	15

SECTION IV. REPAIR PARTS LIST (CONTINUED)

(1) ILLUSTRATION		(2) SMR CODE	(3) NATIONAL STOCK NUMBER	(4) PART NUMBER	(5) FSCM	(6) DESCRIPTION	(7) UNIT OF MEASUREMENT	(8) QTY INC IN UNIT
(A) FIG NO.	(B) ITEM NO.					USABLE CN CODE		
						GROUP: 0113 DECIMAL LOGIC ASSEMBLY		
14	1	^AHZZ		S24496	07263	TRANSISTOR, SILICON, NPN	EA	8
14	2	^AHZZ		324731	39536	PCB, DECIMAL LOGIC	EA	1
14	3	^AHZZ	905-00-126-6683	CB3325	01121	RESISTOR, COMPOSITION: 3.3K ohms +5%, 1/4W	EA	1
14	4	^AHZZ	961-00-892-8706	2N3904	04713	TRANSISTOR, SILICON, NPN	EA	2
14	5	^AHZZ	962-00-252-4535	C4319A	18324	INTEGRATED CIRCUIT, QUAD-2 INPUT NOR GATE	EA	1
14	6	^AHZZ		583527	00779	SOCKET, INTEGRATED CIRCUIT	EA	1
14	7	^AHZZ	905-00-909-3940	CB2225	01121	RESISTOR, COMPOSITION: 2.2K ohms +5%, 1/4W	EA	2
14	8	^AHZZ	985-00-577-9461	CB2235	01121	RESISTOR, COMPOSITION: 22K ohms +5%, 1/4W	EA	2
14	9	^AHZZ	905-00-909-3885	CB1035	01121	RESISTOR, COMPOSITION: 10K ohms +5%, 1/4W	EA	1
14	10	^AHZZ		325001	39536	CABLE ASSEMBLY	EA	1

SECTION IV. REPAIR PARTS LIST (CONTINUED)

	(1) ILLUSTRATION		(2) SMR CODE	(3) NATIONAL STOCK NUMBER	(4) PART NUMBER	(5) FSCM	(6) DESCRIPTION	(7) UNIT OF MEAS	(8) QTY INC IN UNIT
	(A) FIG NO.	(B) ITEM NO.							
							GROUP: 0114 PLUG-IN ELECTRONIC TEST EQUIPMENT PL-1370/GSM64:		
N	15	1	XDRHH	6625-00-1 37-8366	406199	89536	PCB ASSEMBLY, RMS CONVERTER	EA	1
N	15	2	FAHZZ		304048	89536	CABLE ASSEMBLY, INPUT	EA	1
N	15	3	FAHZZ	5975 -00-727 -5153	SST1MC	06383	CLAMP, CABLE	EA	1
N	15	4	FAHZZ		1497B	88245	TERMINAL, STANDOFF	EA	7
N	15	5	FAHZZ	5910-00-144-2472	JF-65	84411	CAPACITOR, MYLAR, 0.22 UF +20%, 1200V	EA	1
N	15	6	FAHZZ	5930-00-403-4621	284091	89536	RELAY, REED SWITCH	EA	2
N	15	7	FAHZZ		269019	89536	COIL, RELAY	EA	5
N	15	8	FAHZZ		313833	89536	WRAP, FOIL, RELAY	EA	2
N	15	9	FAHZZ		SL-841-777	12615	TERMINAL, FEEDTHROUGH, TEFLON	EA	4
N	15	10	FAHZZ	5910-00-244-8375	530-000	72982	CAPACITOR, VAR, TEFLON, 0.25-1.5 PF, 2KV	EA	2
N	15	11	FAHZZ		FME75	03888	RESISTOR, METAL FILM, 1 MEGOHM +0.1%, 1W	EA	1
N	15	12	FAHZZ	5961 -00-909-8091	FD700	07263	DIODE, SILICON, 100 MA, 1.5V	EA	6
N	15	13	FAHZZ		1N754A	81349	DIODE, ZENER, 6.8V	EA	2
N	15	14	FAHZZ		VY10CA2R7CA	95275	CAPACITOR, PORCELAIN, 2.7 PF +0.25 PF, 1700V	EA	1
N	15	15	FAHZZ		3386RMO9-105	80294	RESISTOR, VAR, CERMET, 1 MEGOHM +10%, 1/2W	EA	3
N	15	16	FAHZZ		2N5078	81349	TRANSISTOR, FET, N-CHANNEL	EA	3
N	15	17	FAHZZ		3386RMO9-103	80294	RESISTOR, VAR, CERMET, 1C KILOHM +10%, 1/2W	EA	2
N	15	18	FAHZZ		VY10CA2R2CA	95275	CAPACITOR, PORCELAIN, 2.2 PF +0.25 PF, 1700V	EA	1
N	15	19	FAHZZ	5910-00-901-6230	JMC5201	91293	CAPACITOR, VAR, AIR, 0.8-10 PF, 250V	EA	1
N	15	20	FAHZZ		3386RMO9-102	80294	RESISTOR, VAR, CERMET, 1 KILOHM +10%, 1/2W	EA	1
N	15	21	FAHZZ		538006D935	32897	CAPACITOR, VAR, CERAMIC, 9-35 PF, 350V	EA	1
N	15	22	FAHZZ		VY10CA270JA	95275	CAPACITOR, PORCELAIN, 27 PF +5%, 500V	EA	1
N	15	23	FAHZZ		RW65D9953B	81349	RESISTOR, METAL FILM, 995 KILOHM +0.1%, 1/4W	EA	1
N	15	24	FAHZZ		RNC60H110.6KF	81349	RESISTOR, METAL FILM, 110.6 KILOHM, +0.1%, 1/8W	EA	1
N	15	25	FAHZZ	5905-00-110-0388	RCR07G104JS	81349	RESISTOR, COMPOSITION, 100 KILOHM, +5%, 1/4W	EA	1
N	15	26	FAHZZ	5905-00-106-3668	RCR07G220JS	81349	RESISTOR, COMPOSITION, 22 OHM, +5%, 1/4W	EA	1
N	15	27	FAHZZ		DM15F100J	72915	CAPACITOR, MICA, 100 PF +5%, 500V	EA	1
N	15	28	FAHZZ		DM15F360J	72915	CAPACITOR, MICA, 330 PF +1%, 500V	EA	1
N	15	29	FAHZZ		DM19F3600G	72915	CAPACITOR, MICA, 3600 PF +2%, 500V	EA	1
N	15	30	FAHZZ		RNC60H1.001KB	81349	RESISTOR, METAL FILM, 1.001 KILOHM +0.1%, 1/8W	EA	1
N	15	31	FAHZZ	5945-00-690-1400	289850	89536	RELAY, REED SWITCH	EA	4
N	15	32	FAHZZ		280008	89536	WRAP, FOIL, RELAY	EA	3
N	15	33	FAHZZ	5961-00-471-2492	DHD1105	03508	DIODE, SILICON, 150 MA	EA	6
N	15	34	FAHZZ	5910-00-071-9922	C280AEA100K	73445	CAPACITOR, MYLAR, 0.1 UF +10%, 250V	EA	3
N	15	35	FAHZZ	5910-00-008-6752	C280AEA33K	34553	CAPACITOR, MYLAR, 0.033 UF, +10%, 250V	EA	2
N	15	36	FAHZZ	5905-00-116-8554	RCR07G105JS	81349	RESISTOR, COMPOSITION, 1 MEGOHM +5%, 1/4W	EA	7
N	15	37	FAHZZ		SP50070	12040	TRANSISTOR, FET, N-CHANNEL	EA	5
N	15	38	FAHZZ	5905-00-136-3890	RCR07G513JS	81349	RESISTOR, COMPOSITION, 51 KILOHM +5%, 1/4W	EA	4
N	15	39	FAHZZ	5961-00-931-0372	2N3906	81349	TRANSISTOR, SILICON, PNP	EA	3
N	15	40	FAHZZ	5905-00-116-8556	RCR07G223JS	81349	RESISTOR, COMPOSITION, 22 KILOHM +5%, 1/4W	EA	3

SECTION IV. REPAIR PARTS LIST (CONTINUED)

	(1) ILLUSTRATION		(2) SMR CODE	(3) NATIONAL STOCK NUMBER	(4) PART NUMBER	(5) FSCM	(6) DESCRIPTION USABLE ON CODE	(7) JNIT OF MEAS	(8) QTY IN UNIT
	(A) FIG NO.	(B) ITEM NO.							
N	15	41	PAHZZ	5905-00-136-7104	RCR07G304JS	81349	RESISTOR, COMPOSITION, 300 KILOHM $\pm 5\%$, 1/4W	EA	
N	15	42	PAHZZ	5961-00-892-8706	2N3904	0413	TRANSISTOR, SILICON, NPN	EA	
N	15	43	PAHZZ		DML5C15J	72915	CAPACITOR, MICA, 15 PF $\pm 5\%$, 500V	EA	
N	15	44	PAHZZ		DML5C101K	72915	CAPACITOR, MICA 4 PF $\pm 10\%$, 500V	EA	1
N	15	45	PAHZZ	5910-00-080-5377	C280A0EA47K	73445	CAPACITOR, MYLAR, 0.047 UF $\pm 10\%$, 250V	EA	3
N	15	46	PAHZZ	5905-00-131-9729	RCR07G302JS	81349	RESISTOR, COMPOSITION, 3 KILOHM $\pm 5\%$, 1/4W	EA	1
N	15	47	PAHZZ		DML5C2D	72915	CAPACITOR, MICA, 2 PF ± 15 PF, 500V	EA	2
N	15	48	PAHZZ	5962-00-236-0319	LM318H	12040	IC, OPERATIONAL AMPLIFIER	EA	1
N	15	49	PAHZZ	5961-00-402-2014	2N5197	81349	TRANSISTOR, PEP, DUAL, N-CHANNEL	EA	1
N	15	50	PAHZZ		150D15X9020B2	56289	CAPACITOR, TANTALUM, 15 UF $\pm 10\%$, 20V	EA	3
N	15	51	PAHZZ		RNC60H5002B	81349	RESISTOR, METAL FILM, 50 KILOHM $\pm 0.1\%$, 1/8W	EA	3
N	15	52	PAHZZ	5905-00-404-9172	RNC60H4872FS	81349	RESISTOR, METAL FILM, 48.7 KILOHM $\pm 1\%$, 1/8W	EA	1
N	15	53	PAHZZ		272070	89536	COIL, RELAY	EA	1
N	15	54	PAHZZ	5905-00-106-1278	RCR07G123JS	81349	RESISTOR, COMPOSITION, 12 KILOHM $\pm 5\%$, 1/4W	EA	2
N	15	55	PAHZZ	5905-00-121-9932	RCR07G391JS	81349	RESISTOR, COMPOSITION, 390 OHM $\pm 5\%$, 1/4W	EA	1
N	15	56	PAHZZ		MS51957-26	96906	SCREW, STEEL, 6-32 X 1/4	EA	3
N	15	57	PAHZZ	5905-00-435-6374	RCR07G823JS	81349	RESISTOR, COMPOSITION, 82 KILOHM $\pm 5\%$, 1/4W	EA	1
N	15	58	PAHZZ	5905-00-114-5344	RCR07G184JS	81349	RESISTOR, COMPOSITION, 180 KILOHM $\pm 5\%$, 1/4W	EA	1
N	15	59	PAHZZ	5905-00-141-0717	RCR07G473JS	81349	RESISTOR, COMPOSITION, 47 KILOHM $\pm 5\%$, 1/4W	EA	1
N	15	60	PAHZZ	5962-00-184-8205	MC858P	04713	IC, DTL, QUAD 2 INPUT NAND GATE	EA	1
N	15	61	PAHZZ	5962-00-066-0176	MC862P	04713	IC, DTL, TRIPLE 3 INPUT NAND GATE	EA	1
N	15	62	PAHZZ	5961-00-556-2091	1N270	99180	DIODE, GERMANIUM, 80 MA, 100PIV	EA	5
N	15	63	PAHZZ		23021	10389	SWITCH, SLIDE, SINGLE POLE DOUBLE THROW	EA	1
N	15	64	PAHZZ		3386RM09-050	80294	RESISTOR, VAR, CERMET, 50 OHM $\pm 10\%$, 1/2W	EA	1
N	15	65	PAHZZ	5905-00-204-7747	RNC60H1004FS	18349	RESISTOR, METAL FILM, 1 MEGOHM $\pm 1\%$, 1/8W	EA	1
N	15	66	PAHZZ	5905-00-135-3975	RCR07G680JS	81349	RESISTOR, COMPOSITION, 68 OHM $\pm 5\%$, 1/4W	EA	1
N	15	67	PAHZZ	5905-00-110-7622	RCR07G682JS	81349	RESISTOR, COMPOSITION, 6.8 KILOHM $\pm 5\%$, 1/4W	EA	2
N	15	68	PAHZZ	5905-00-106-9356	RCR07G203JS	81349	RESISTOR, COMPOSITION, 20 KILOHM $\pm 5\%$, 1/4W	EA	1
N	15	69	PAHZZ	5905-00-146-4173	RNC60H8871FS	81349	RESISTOR, METAL FILM, 8.87 KILOHM $\pm 1\%$, 1/8W	EA	1
N	15	70	PAHZZ	5905-00-407-2160	RNC60H1003FS	81349	RESISTOR, METAL FILM 100 KILOHM $\pm 0.1\%$, 1/8W	EA	1
N	15	71	PAHZZ		RNC60H1702P	81349	RESISTOR, METAL FILM 17 KILOHM $\pm 1\%$, 1/8W	EA	1
N	15	72	PAHZZ	5905-00-471-5651	RNC60H3572FS	81349	RESISTOR, METAL FILM, 35.7 KILOHM $\pm 1\%$, 1/8W	EA	1
N	15	73	PAHZZ		DML9F1000J	72915	CAPACITOR, MICA, 1000 PF $\pm 5\%$, 1500V	EA	2
N	15	74	PAHZZ	5905-00-758-3316	RNC60H3402FS	81349	RESISTOR, METAL FILM, 34 KILOHM $\pm 1\%$, 1/8W	EA	1
N	15	75	PAHZZ		DME15E27J	72915	CAPACITOR, MICA, 27 PF $\pm 5\%$, 1500V	EA	2
N	15	76	PAHZZ		LM308AH	12040	IC, OPERATIONAL AMPLIFIER	EA	1
N	15	77	PAHZZ		RNC60H4653FS	81349	RESISTOR, METAL FILM, 465 KILOHM $\pm 0.25\%$, 1/8W	EA	1
N	15	78	PAHZZ	5905-00-133-0440	RCR07G560JS	81349	RESISTOR, COMPOSITION, 560 OHM $\pm 5\%$, 1/4W	EA	1
N	15	79	PAHZZ		DML5E33J	72915	CAPACITOR, MICA 33 PF $\pm 5\%$, 500V	EA	3
N	15	80	PAHZZ	5905-00-451-7412	RNC60H4993FS	81349	RESISTOR, METAL FILM, 499 KILOHM $\pm 1\%$, 1/8W	EA	1

SECTION IV. REPAIR PARTS LIST (CONTINUED)

	(1) ILLUSTRATION		(2) SMR CODE	(3) NATIONAL STOCK NUMBER	(4) PART NUMBER	(5) FSCM	(6) DESCRIPTION	(7) UNIT OF MEAS	(8) QTY INC IN UNIT
	(A) FIG NO.	(B) ITEM NO.							
#	15	81	PAHZZ		LM308H	12040	IC, OPERATIONAL AMP LIFIER	EA	2
#	15	82	PAHZZ	5961-00-365-9660	TD12599	07910	DIODE, SILICON, 10 MA, 2 PIV	EA	1
#	15	83	PAHZZ	5905-00-135-6045	RCR07G330JS	81349	RESISTOR, COMPOSITION, 33 0OHM, +5%, 1/4W	EA	2
#	15	84	PAHZZ	5905-00-110-7620	RCR07G102JS	81349	RESISTOR, COMPOSITION, 1 KILOHM, +5%, 1/4W	EA	2
#	15	85	PAHZZ		RNC60H10R0F	09969	RESISTOR, METAL FILM, 10 OHM ±1%, 1/8W	EA	1
#	15	86	PAHZZ	5910-00-816-3142	DM15F390J	72915	CAPACITOR, MICA, 390 PF +5%, 500V	EA	1
#	15	87	KFHZZ			89536	RESISTOR, PART OF MATCHED SET P/N 361048	EA	1
#	15	88	KFHZZ			89536	RESISTOR, PART OF MATCHED SET P/N 361048	EA	1
#	15	89	PAHZZ		26018D	05820	HEAT SINK	EA	1
#	15	90	KFHZZ			89536	RESISTOR, PART OF MATCHED SET P/N 361048	EA	1
#	15	91	PAHZZ	5905-00-104-8368	RCR07G470JS	81349	RESISTOR, COMPOSITION, 470 OHM +5%, 1/4W	EA	2
#	15	92	PAHZZ		360T105A	11236	RESISTOR, VAR, CERMET, 1 MEGOHM ±10%, 1/2W	EA	2
#	15	93	PAHZZ		C280AEA6K8	34553	CAPACITOR, MYLAR, 6800 PF ±10%, 250V	EA	3
#	15	94	PAHZZ	5905-00-061-1332	RN65D2004F	81349	RESISTOR, METAL FILM 2 MEGOHM ±1%, 1/4W	EA	1
#	15	95	KFHZZ			89536	TRANSISTOR, PART OF MATCHED SET P/N 361048	EA	2
#	15	96	PAHZZ		3329HJ81-3R0	80294	RESISTOR, VAR, CERMET, 3 OHM ±25%, 1/2W	EA	1
#	15	97	PAHZZ	5910-00-776-4367	C280AEA22K	73445	CAPACITOR, MYLAR, 0.022 UF ±10%, 250V	EA	2
#	15	98	PAHZZ		RN65D1004C	81349	RESISTOR, METAL FILM, 1 MEGOHM ±0.25%, 1/4W	EA	2
#	15	99	PAHZZ		1N961A	81349	DIODE, ZENER, 10V	EA	3
#	15	100	PAHZZ	5961-00-617-4713	MPS6520	04713	TRANSISTOR, SILICON, NPN	EA	1
#	15	101	PAHZZ	5905-00-141-0744	RCR07G562JS	81349	RESISTOR, COMPOSITION, 5.6 KILOHM +5%, 1/4W	EA	1
#	15	102	PAHZZ	5905-00-106-1357	RCR07G563JS	81349	RESISTOR, COMPOSITION, 56 KILOHM +5%, 1/4W	EA	1
#	15	103	PAHZZ	5905-00-115-2261	RCR07G912JS	81349	RESISTOR, COMPOSITION, 9.1 KILOHM +5%, 1/4W	EA	1
#	15	104	PAHZZ		LM301A	12040	IC, OPERATIONAL AMPLIFIER	EA	1
#	15	105	PAHZZ	5961-00-349-6215	TCR5309	07910	REGULATOR, CURRENT	EA	1
#	15	106	PAHZZ	5905-00-105-7767	RCR07G474JS	81349	RESISTOR, COMPOSITION, 470 KILOHM +5%, 1/4W	EA	1
#	15	107	PAHZZ	5905-00-113-4858	RCR07G754JS	81349	RESISTOR, COMPOSITION, 750 KILOHM +5%, 1/4W	EA	1
#	15	108	PAHZZ	5905-00-136-7103	RCR07G204JS	81349	RESISTOR, COMPOSITION, 200KILOHM +5%, 1/4W	EA	1
#	15	109	PAHZZ		C350APA4K7	34553	CAPACITOR, MYLAR, 4700 PF ±10%, 250V	EA	1
#	15	110	PAHZZ	5962-00-132-6389	SG-8023	34333	IC, OPERATIONAL AMPLIFIER	EA	1
#	15	111	PAHZZ	5905-00-111-1679	RCR07G512JS	81349	RESISTOR, COMPOSITION, 5.1 KILOHM +5%, 1/4W	EA	1
#	15	112	PAHZZ	5905-00-141-0743	RCR07G392JS	81349	RESISTOR, COMPOSITION, 3.9 KILOHM +5%, 1/4W	EA	1
#	15	113	PAHZZ		RNC60H10.05B	81349	RESISTOR, METAL FILM, 10.05 KILOHM ±0.01%, 1/8W	EA	1
#	15	114	PAHZZ		RNC60H4.975K	81349	RESISTOR, METAL FILM 4.975 KILOHM ±0.1%, 1/8W	EA	1
#	15	115	PAHZZ		RNC60H5001B	81349	RESISTOR, METAL FILM, 5 KILOHM ±0.1%, 1/8W	EA	1
#	15	116	PAHZZ	5905-00-471-2259	RNC60H1000FS	81349	RESISTOR, METAL FILM, 100 OHM ±1%, 1/8W	EA	1
#	15	117	PAHZZ		3386 RM09-101	80294	RESISTOR, VAR, CERMET, 100 OHM ±10%, 1/2W	EA	1
#	15	118	PAHZZ		345561	89536	SHIELD INPUT	EA	1
#	15	119	PAHZZ		339366	89536	COVER PCB, SHIELD	EA	1
#	15		PAHZZ		361048	89536	TC MATCHED SET	EA	1
#	15	87					RESISTOR	EA	1
#	15	88					RESISTOR	EA	1
#	15	90					RESISTOR	EA	1
#	15	95					TRANSISTOR	EA	2

SECTION VI. NATIONAL STOCK NUMBER AND PART NUMBER INDEX

NOTE: LATEST NATIONAL STOCK NUMBER AND PART NUMBER ASSIGNMENTS ARE INCLUDED AT END OF INDEX

STOCK NUMBER	FIG. NO.	ITEM NO.	STOCK NUMBER	FIG. NO.	ITEM NO.
5355-00-242-9535	10	3	5905-00-766-9392	13	44
5355-00-449-3096	10	2	5905-00-882-2723	6	19
5905-00-055-6121	3	4	5905-00-882-2723	13	16
5905-00-055-7051	7	72	5905-00-904-5676	5	53
5905-00-072-0647	11	16	5905-00-904-5677	5	64
5905-00-087-1160	3	10	5905-00-904-5677	6	31
5905-00-104-8360	5	17	5905-00-904-5677	7	23
5905-00-104-8368	6	36	5905-00-904-5677	9	51
5905-00-105-7765	3	25	5905-00-904-5677	13	3
5905-00-105-7765	5	48	5905-00-904-5689	5	23
5905-00-105-7765	6	12	5905-00-904-5689	7	13
5905-00-105-7765	7	31	5905-00-905-6278	13	48
5905-00-106-3156	6	39	5905-00-905-6279	6	16
5905-00-110-7622	8	25	5905-00-905-6279	13	50
5905-00-110-7622	13	23	5905-00-907-4119	6	44
5905-00-113-4860	13	52	5905-00-909-3885	4	11
5905-00-116-8554	9	2	5905-00-909-3885	6	2
5905-00-119-3505	3	28	5905-00-909-3885	7	42
5905-00-119-3505	7	38	5905-00-909-3885	9	10
5905-00-126-6683	9	13	5905-00-909-3885	9	28
5905-00-135-6046	6	43	5905-00-909-3885	13	20
5905-00-136-3890	4	21	5905-00-909-3885	14	9
5905-00-136-3890	6	8	5905-00-909-3940	6	18
5905-00-126-6683	14	3	5905-00-909-3940	13	9
5905-00-141-0743	13	47	5905-00-909-3940	14	7
5905-00-153-5730	7	67	5905-00-909-3965	9	52
5905-00-153-5734	7	65	5905-00-909-3965	13	43
5905-00-153-5785	3	18	5905-00-909-3967	6	45
5905-00-153-5785	5	6	5905-00-909-3967	7	49
5905-00-153-6180	7	71	5905-00-909-3967	13	56
5905-00-156-6459	4	8	5905-00-911-3753	4	18
5905-00-156-6459	7	58	5905-00-911-3753	5	36
5905-00-156-6459	9	16	5905-00-911-3753	6	28
5905-00-156-6478	5	29	5905-00-911-3753	7	35
5905-00-169-3864	9	22	5905-00-911-3753	13	49
5905-00-279-2281	9	4	5905-00-911-3754	4	20
5905-00-402-4258	7	63	5905-00-911-3801	7	21
5905-00-413-2605	9	55	5905-00-911-3815	4	17
5905-00-449-0007	8	16	5905-00-911-3815	6	30
5905-00-472-6502	5	18	5905-00-911-3815	7	11
5905-00-553-9318	9	18	5905-00-916-7267	13	5
5905-00-577-9494	13	24	5905-00-916-7268	13	55
5905-00-577-9597	7	5	5905-00-918-6522	6	40
5905-00-683-2236	13	46	5905-00-918-6522	13	41
5905-00-683-2240	4	12	5905-00-919-5713	6	52
5905-00-683-2240	7	39	5905-00-919-5713	13	15
5905-00-741-0744	3	21	5905-00-959-1202	7	12
5905-00-741-0744	7	50	5905-00-959-1202	8	20

SECTION VI. NATIONAL STOCK NUMBER AND PART NUMBER INDEX (CONTINUED)

STOCK NUMBER	FIG. NO.	ITEM NO.	STOCK NUMBER	FIG. NO.	ITEM NO.
5905-00-960-0126	4	10	5961-00-188-8590	3	26
5905-00-960-0126	6	46	5961-00-400-4545	3	1
5905-00-960-0126	7	36	5961-00-400-4545	13	14
5905-00-960-0207	7	69	5961-00-400-5364	4	25
5905-00-968-6140	7	27	5961-00-402-1979	7	17
5905-00-989-1969	6	9	5961-00-402-1979	7	28
5905-00-989-1969	13	36	5961-00-402-1995	5	43
5905-00-989-2443	7	20	5961-00-402-1995	7	24
5905-00-989-3753	6	13	5961-00-402-1996	7	25
5905-00-989-7943	13	4	5961-00-402-2014	7	30
5905-00-994-6676	7	33	5961-00-413-0304	6	5
5905-00-994-6676	9	24	5961-00-413-0304	9	40
5910-00-003-4662	3	8	5961-00-471-2492	4	16
5910-00-080-5377	7	62	5961-00-471-2492	5	4
5910-00-110-7493	13	35	5961-00-471-2492	6	15
5910-00-402-0299	3	11	5961-00-471-2492	7	9
5910-00-459-8641	5	41	5961-00-471-2492	8	22
5910-00-459-8641	7	22	5961-00-471-2492	9	5
5910-00-577-3281	9	47	5961-00-471-2492	13	2
5910-00-577-3281	13	22	5961-00-475-4985	6	47
5910-00-649-2914	5	33	5961-00-497-9132	3	14
5910-00-649-2914	9	44	5961-00-617-4750	8	8
5910-00-716-4950	3	6	5961-00-617-4750	9	41
5910-00-716-4950	5	22	5961-00-731-1235	9	37
5910-00-716-4950	6	49	5961-00-888-5468	5	19
5910-00-716-4950	7	18	5961-00-888-5468	7	44
5910-00-716-4950	8	6	5961-00-890-0662	13	40
5910-00-716-4950	9	46	5961-00-892-0734	9	9
5910-00-789-2924	6	3	5961-00-892-8706	3	9
5910-00-789-2924	9	17	5961-00-892-8706	4	3
5910-00-810-4849	7	14	5961-00-892-8706	5	14
5910-00-810-4849	13	32	5961-00-892-8706	6	10
5910-00-816-3142	5	51	5961-00-892-8706	7	3
5910-00-816-3142	7	26	5961-00-892-8706	8	9
5910-00-828-1133	13	53	5961-00-892-8706	14	4
5910-00-914-2301	6	29	5961-00-908-9666	3	24
5910-00-988-4344	13	54	5961-00-908-9666	6	55
5915-00-498-6059	13	38	5961-00-908-9666	7	73
5920-00-280-8344	12	1	5961-00-908-9666	9	42
5930-00-439-0687	8	24	5961-00-908-9666	13	57
5930-00-539-7013	11	8	5961-00-931-0372	5	2
5940-00-463-7270	9	25	5961-00-931-0372	6	11
5940-00-729-2448	12	3	5961-00-931-0372	7	2
5950-00-175-8660	5	28	5961-00-931-0372	8	14
5950-00-175-8660	8	23	5961-00-931-0372	9	27
5950-00-175-8660	9	7	5961-00-931-0372	13	25
5950-00-477-1189	5	65	5961-00-931-6137	5	25
5950-00-477-1189	9	6	5961-00-932-0551	7	16
5961-00-070-7481	3	15	5961-00-979-0108	3	3
5961-00-142-8925	9	50	5961-00-985-9073	3	2
5961-00-144-2468	7	29	5961-00-985-9077	4	23

SECTION VI. NATIONAL STOCK NUMBER AND PART NUMBER INDEX (CONTINUED)

STOCK NUMBER	FIG. NO.	ITEM NO.	STOCK NUMBER	FIG. NO.	ITEM NO.
5961-00-985-9077	6	48	5905-00-141-0744	15	101
5961-00-988-7401	3	12	5905-00-146-4173	15	69
5961-00-988-7401	6	6	5905-00-204-7747	15	65
5962-00-066-0171	6	41	5905-00-404-9172	15	52
5962-00-184-8205	9	53	5905-00-407-2160	15	70
5962-00-252-4535	14	5	5905-00-435-6374	15	57
5962-00-252-4927	9	14	5905-00-451-7412	15	80
5962-00-350-8423	4	26	5905-00-471-2259	15	116
5962-00-350-8424	4	27	5905-00-471-5651	15	72
5962-00-476-8358	13	37	5905-00-758-3316	15	74
5962-00-487-7007	4	29	5910-00-008-6752	15	35
5962-00-487-7007	6	20	5910-00-071-9922	15	34
5962-00-563-1929	3	7	5910-00-080-5377	15	45
5962-00-563-1929	5	31	5910-00-144-2472	15	5
5962-00-563-1929	6	53	5910-00-197-0192	15	109
5962-00-563-1929	7	16	5910-00-244-8375	15	10
5962-00-563-1929	8	4	5910-00-776-4367	15	97
5962-00-985-1512	9	48	5910-00-816-3142	15	86
5962-00-985-1755	5	30	5910-00-901-6230	15	19
5975-00-906-2414	12	10	5920-00-875-4100	12	2
5985-00-577-9461	4	22	5930-00-403-4621	18	6
5985-00-577-9461	6	14	5930-00-655-1575	11	7
5985-00-577-9461	7	48	5935-00-263-6641	2	11
5986-00-577-9461	14	8	5945-00-690-1400	15	31
6240-00-183-0658	10	28	5961-00-160-3698	13	6
<u>LATEST NATIONAL STOCK NUMBER ASSIGNMENTS</u>					
5905-00-061-1332	15	94	5961-00-349-6215	15	105
5905-00-104-8368	15	91	5961-00-365-9660	15	82
5905-00-105-7767	15	106	5961-00-402-2014	15	49
5905-00-106-1278	15	54	5961-00-471-2492	15	33
5905-00-106-1357	15	102	5961-00-556-2091	13	7
5905-00-106-3668	15	26	5961-00-556-2091	15	62
5905-00-106-9356	15	68	5961-00-617-4713	15	100
5905-00-110-0388	15	25	5961-00-892-8706	13	10
5905-00-110-7620	15	84	5961-00-892-8706	15	42
5905-00-110-7622	15	67	5961-00-909-8091	15	12
5905-00-111-1679	15	111	5961-00-931-0372	15	39
5905-00-113-4858	15	107	5962-00-066-0176	15	61
5905-00-114-5344	15	58	5962-00-132-6389	15	10
5905-00-115-2261	15	103	5962-00-184-8205	15	60
5905-00-116-8554	15	36	5962-00-236-0319	15	48
5905-00-116-8556	15	40	5975-00-727-5153	15	3
5905-00-121-9932	15	55	5930-00-013-1073	11	5
5905-00-131-9729	15	46	6625-00-137-8366	15	1
5905-00-133-0440	15	78			
5905-00-135-3475	15	66			
5905-00-135-6045	15	83			
5905-00-136-3890	15	38			
5905-00-136-7103	15	108			
5905-00-136-7104	15	41			
5905-00-141-0717	15	59			
5905-00-141-0743	15	112			

SECTION VI. NATIONAL STOCK NUMBER AND PART NUMBER INDEX (CONTINUED)

PART NUMBER	FSCM	FIG. NO.	ITEM NO.	PART NUMBER	FSCM	FIG. NO.	ITEM NO.
BB60181KS3N	71590	6	29	CB3325	01121	9	13
BB60301KW7W	71590	13	54	CB3325	01121	14	3
B5853ST	83594	13	39	CB3335	01121	6	45
B5856ST	83594	13	45	CB3335	01121	7	49
CB1025	01121	5	64	CB3335	01121	13	56
CB1025	01121	6	31	CB3905	01121	13	38
CB1025	01121	7	23	CB3915	01121	13	46
CB1025	01121	9	51	CB3925	01121	13	47
CB1025	01121	13	3	CB3935	01121	6	44
CB1035	01121	4	11	CB4315	01121	13	44
CB1035	01121	6	2	CB4705	01121	6	36
CB1035	01121	7	42	CB4715	01121	13	24
CB1035	01121	9	10	CB4725	01121	4	18
CB1035	01121	9	28	CB4725	01121	5	36
CB1035	01121	13	20	CB4725	01121	6	28
CB1035	01121	14	9	CB4725	01121	7	35
CB1045	01121	7	12	CB4725	01121	13	49
CB1045	01121	8	20	CB4735	01121	4	10
CB1055	01121	9	2	CB4735	01121	6	46
CB1135	01121	6	13	CB4735	01121	7	36
CB1225	01121	6	52	CB51G5	01121	5	18
CB1225	01121	13	15	CB5125	01121	4	20
CB1235	01121	13	4	CB5135	01121	4	21
CB1245	01121	5	53	CB5135	01121	6	8
CB1525	01121	6	39	CB5145	01121	7	72
CB1535	01121	5	23	CB5625	01121	3	21
CB1535	01121	7	13	CB5625	01121	7	50
CB1545	01121	7	5	CB62G5	01121	5	9
CB1635	01121	13	48	CB6235	01121	5	17
CB1825	01121	6	16	CB6255	01121	7	63
CB1825	01121	13	50	CB6815	01121	6	43
CB1835	01121	7	21	CB6825	01121	8	25
CB2205	01121	7	20	CB6825	01121	13	23
CB2215	01121	4	12	CB6835	01121	3	28
CB2215	01121	7	39	CB6835	01121	7	38
CB2225	01121	6	18	CB6835	01121	13	55
CB2225	01121	13	9	CB7535	01121	6	40
CB2225	01121	14	7	CB8215	01121	13	41
CB2235	01121	4	22	CB8215	01121	6	9
CB2235	01121	6	14	CB8225	01121	13	36
CB2235	01121	7	48	CB8225	01121	13	5
CB2235	01121	14	8	CB8235	01121	7	27
CB2245	01121	3	25	CB8245	01121	8	8
CB2245	01121	5	48	CD12599	07910	9	41
CB2245	01121	6	12	CD12599	07910	3	6
CB2245	01121	7	31	CD15E330J	14655	5	22
CB2705	01121	13	52	CD15E330J	14655	6	49
CB2725	01121	6	19	CD15E330J	14655	7	18
CB2725	01121	13	16	CD15E330J	14655	8	6
CB2735	01121	4	17	CD15E330J	14655	9	46
CB2735	01121	6	30	CD15F101J	14655	5	33
CB2735	01121	7	11	CD15F101J	14655	9	44
CB2765	01121	5	34	CD15F151J	14655	8	11
CB3055	01121	7	69	CD15F271J	14655	6	3
CB3315	01121	9	52	CD15F271J	14655	9	17
CB3315	01121	13	43	CD15F391J	14655	5	51

SECTION VI. NATIONAL STOCK NUMBER AND PART NUMBER INDEX (CONTINUED)

PART NUMBER	FS CM	FIG. NO.	ITEM NO.	PART NUMBER	FSCM	FIG. NO.	ITEM NO.
CD15F391J	14655	7	26	LM301A	12040	3	7
CD19F152J	14655	6	37	LM301A	12040	5	31
CD19F222J	14655	9	20	LM301A	12040	6	53
CD19F471J	14655	6	32	LM301A	12040	7	16
CD19F562G	14655	6	33	LM301A	12040	8	4
CD36554	07910	7	10	LM308AH	12040	5	30
CD55105	07910	5	43	LM308H	12040	9	14
CD55105	07910	7	24	LM310H	12040	9	48
CFE13041	07910	7	25	MC846P	04713	6	41
CLIN150	00656	7	57	MC858P	04713	9	53
C023B101E502M	56289	13	35	MFF1-21001F	91637	9	26
C023B101F103M	56289	7	14	MFF1-21503F	91637	5	38
C023B101F103M	56289	13	32	MFF1-22152F	91637	7	74
C128B101H253M	56289	4	5	MFF1-27503F	91637	6	26
C128B101H253M	56289	13	19	MFF1-41R55F	91637	7	68
C280AEA47K	73445	7	62	MFF1-81001F	91637	7	61
C280AEA47OK	73445	5	41	MFF1-81002F	91637	3	5
C280AEA47OK	73445	7	22	MFF1-81002F	91637	5	45
C280CFA47	73445	5	35	MFF1-81002F	91637	9	30
C426ARE20	73445	13	53	MFF1-81003F	91637	8	5
C4312A	18324	6	22	MFF1-81003F	91637	9	34
C4312A	18324	13	33	MFF1-81033F	91637	4	9
C4319A	18324	14	5	MFF1-81103F	91637	6	35
C4321A	18324	6	24	MFF1-81211F	91637	5	27
DHD1105	03508	4	16	MFF1-81372F	91637	9	31
DHD1105	03508	5	4	MFF1-81403F	91637	8	10
DHD1105	03508	6	15	MFF1-81502F	91637	4	14
DHD1105	03508	7	9	MFF1-81503F	91637	5	37
DHD1105	03508	8	22	MFF1-81582F	91637	5	7
DHD1105	03508	9	5	MFF1-816R9F	91637	7	54
DHD1105	03508	13	2	MFF1-81692F	91637	4	6
DM8840N	12040	13	37	MFF1-81821F	91637	5	26
DN423	17856	7	29	MFF1-81823F	91637	6	7
DN503	17856	7	30	MFF1-81871F	91637	5	5
D20F103F	53021	4	7	MFF1-81911F	91637	9	33
EB10G5	01121	7	33	MFF1-82001F	91637	8	13
EB10G5	01121	9	24	MFF1-82153F	91637	8	15
EB1061	01121	11	16	MFF1-82212F	91637	7	51
EB1071	01121	9	18	MFF1-82261F	91637	5	16
EB5105	01121	3	4	MFF1-82320F	91637	9	36
EB5115	01121	3	10	MFF1-82322F	91637	5	13
ET221X040A01	73445	3	16	MFF1-82431F	91637	5	46
ET221X010A5	73445	4	19	MFF1-82491F	91637	5	50
ET470X025A4	73445	3	8	MFF1-82491F	91637	8	18
FD333	07263	5	19	MFF1-82492F	91637	9	32
FD333	07263	7	44	MFF1-82742F	91637	4	15
FHN26G1	71400	12	2	MFF1-828R7F	91637	5	11
FTE12	98291	9	25	MFF1-82872F	91637	5	42
F02A250V1-2A	81349	12	1	MFF1-83R743PORM1PCT	91637	6	54
GA3937A	01295	7	64	MFF1-83242F	91637	7	8
GA3938A	01295	7	6	MFF1-83572F	91637	5	40
GB4735	01121	9	55	MFF1-83652F	91637	4	13
HB9145	01121	9	4	MFF1-83741F	91637	6	4
HVD347PORM10PCT	56289	11	17	MFF1-83833F	91637	3	27
JC4284	71590	13	29	MFF1-840R2F	91637	3	22
MC836P	04713	4	26	MFF1-84322F	91637	5	56
MC862P	04713	4	27	MFF1-84422F	91637	9	29

SECTION VI. NATIONAL STOCK NUMBER AND PART NUMBER INDEX (CONTINUED)

PART NUMBER	FSCM	FIG. NO.	ITEM NO.	PART NUMBER	FSCM	FIG. NO.	ITEM NO.
MFF1-84532F	91637	7	41	X463VW105950W	84411	5	49
MFF1-84643F	91637	6	34	09389751	24655	11	14
MFF1-84643F	91637	8	3	1N270	93332	4	2
MFF1-84991F	91637	5	47	1N270	93332	5	3
MFF1-84991F	91637	7	7	1N270	93332	6	17
MFF1-84992F	91637	7	43	1N270	93332	7	47
MFF1-86041F	91637	5	15	1N270	93332	9	19
MFF1-86041F	91637	7	60	1N270	93332	13	7
MFF1-86650F	91637	5	24	1N276	18927	4	25
MFF1-87151F	91637	8	12	1N456A	93332	9	9
MFF1-87503F	91637	7	66	1N4817	05277	3	12
MFF1-88252F	91637	8	19	1N4817	05277	6	6
MFF1-88661F	91637	8	21	1N4822	05277	3	15
MFF1-89R53F	91637	3	23	1N754	07910	9	49
MFF1813R7F	91637	5	8	1N963B	07910	3	26
MS3102R3610S	81349	12	12	104045036S	83298	12	14
MS3505922	96906	11	7	1061	91886	12	3
M121-23R834F	00327	9	39	109317	88245	11	9
N1030B	97539	11	8	109317	88245	12	15
QD10178E	11726	7	70	128B101H253M	56289	6	27
QD10178E	11726	9	43	150F335X5020B	56289	4	24
QD20078	11726	8	7	158956	89536	10	2
QD20078	11726	9	38	190C201B	71450	7	52
RN60XXXXF	81349	8	17	190PC101B	71450	9	22
RN60XXXXF	81349	9	11	190PC102B	71450	9	21
RS2048	49956	7	4	190PC104B	71450	9	23
R40E0303	77342	5	39	190PC200B	71450	6	51
R40E0303	77342	9	3	190PC200B	71450	7	46
SG8023	34333	5	21	190PC502B	71450	8	16
SL841777	12615	9	57	190249	89536	10	3
SN15832N	01295	4	29	2N1303	01295	6	47
SN15832N	01295	6	20	2N1307	01295	9	37
SN7416P	01295	13	17	2N3053	95303	3	2
SPF179	04713	7	17	2N3391	03508	4	23
SPF179	04713	7	28	2N3391	03508	6	48
SSC2	06383	12	10	2N3391	03508	13	21
S19254	07263	6	5	2N3904	94713	3	9
S19254	07263	9	40	2N3904	94713	4	3
S24496	07263	13	42	2N3904	94713	5	14
S24496	07263	14	1	2N3904	94713	6	10
S37234	07263	9	50	2N3904	94713	7	3
TSA290014W	23880	4	28	2N3904	94713	8	9
TSA290014W	23880	6	21	2N3904	94713	13	10
TSA290014W	23880	9	54	2N3904	94713	14	4
TSA290016W	23880	6	23	2N3906	04713	5	2
TYPEMRR5	12617	9	8	2N3906	04713	6	11
T3R722CS	08844	2	5	2N3906	04713	7	2
UD6P	71707	5	28	2N3906	04713	8	14
UD6P	71707	8	23	2N3906	04713	9	27
UD6P	71707	9	7	2N3906	04713	13	25
V2412	15818	7	28	2N4037	95303	3	3
V2412	15818	7	45	2N4888	07263	13	40
V2412	15818	13	12	2N4946	07263	5	25
V6P	71707	5	55	2N6027	03508	4	4
V6P	71707	9	6	2N6027	03508	6	38
X463VW1059.50	84411	5	52	2N6027	03508	13	6

SECTION VI. NATIONAL STOCK NUMBER AND PART NUMBER INDEX (CONTINUED)

PART NUMBER	FSCM	FIG. NO.	ITEM NO.	PART NUMBER	FSCM	FIG. NO.	ITEM NO.
210	17537	10	28	324186	89536	11	4
21040600	78189	11	11	324194	89536	10	25
21040600	78189	12	7	324202	89536	10	20
2185	83330	2	11	324210	89536	10	9
240937	89536	3	20	324228	89536	10	22
274795	89536	7	32	324699	89536	10	15
275321	89536	6	50	324707	89536	10	12
284240	89536	13	13	324715	89536	10	10
284505	89536	9	12	324723	89536	5	1
285239	89536	7	37	324731	89536	14	2
287623	89536	5	12	324749	89536	12	13
288647	89536	7	53	324756	89536	2	25
288654	89536	7	56	324756	89536	10	23
289850	89536	5	32	324764	89536	2	21
289850	89536	9	58	324772	89536	2	13
290320	89536	9	45	324780	89536	2	14
290650	89536	6	1	324798	89536	10	24
291690	89536	7	40	324806	89536	2	26
291807	89536	2	17	324806	89536	10	30
293498	89536	13	59	324946	89536	10	6
295121	89536	3	19	324962	89536	2	23
295329	89536	2	16	342962	89536	10	1
295337	89536	6	42	324970	89536	2	24
295337	89536	7	15	324970	89536	10	4
297705	89536	10	14	324988	89536	12	17
297747	89536	10	17	325001	89536	14	10
297754	89536	10	13	325019	89536	12	11
297820	89536	13	27	325035	89536	13	26
297846	89536	10	31	325043	89536	9	56
297937	89536	10	11	325050	89536	13	31
298810	89536	10	26	325977	89536	13	30
298836	89536	10	21	325985	89536	13	28
298885	89536	10	16	326181	89536	10	7
298893	89536	9	35	326199	89536	10	8
298919	89536	10	29	326322	89536	10	35
301382	89536	10	32	326330	89536	11	2
301390	89536	10	33	326462	89536	2	22
301481	89536	10	19	326538	89536	10	5
306241	ZZZZZ	12	9	327130	89536	11	15
307298	89536	10	38	327148	89536	9	1
311597	89536	10	34	329441	89536	2	19
320283	89536	11	5	329458	89536	13	1
321398	89536	7	59	329466	89536	7	1
321638	89536	9	15	329474	89536	4	1
323865	89536	5	20	330126	89536	5	44
323980	89536	11	1	331751	89536	2	12
323998	89536	12	16	333559	89536	2	1
324020	89536	10	36	333567	89536	2	3
324046	89536	2	2	336057	89536	2	15
324053	89536	11	6	337600	89536	6	25
324061	89536	2	4	337618	89536	3	13
324079	89536	10	37	337626	89536	8	1
324129	89536	2	7	337634	89536	2	18
324137	89536	2	9	337642	89536	2	20
324145	89536	2	10	36 OS101A	71450	7	67
324178	89536	10	18	36 OS103A	71450	4	8

HISA-FM 2883-2-74

SECTION VI. NATIONAL STOCK NUMBER AND PART NUMBER INDEX (CONTINUED)

PART NUMBER	FSCM	FIG. NO.	ITEM NO.	PART NUMBER	FSCM	FIG. NO.	ITEM NO.
36 OS103A	71450	7	58	DM19F1000J	72915	15	73
36 OS103A	71450	9	16	DM19F3600G	72915	15	29
360 S200B	71450	5	10	C280AEA100K	73445	15	34
360 S200B	71450	7	55	FD700	07263	15	12
360S201A	71450	7	71	JF-65	84411	15	5
360S500A	71450	7	65	JMC5201	91293	15	19
360S501A	71450	3	18	LM3 01A	12040	15	104
360S501A	71450	5	6	LM308AH	12040	15	76
360S502A	71450	5	29	LM308H	12040	15	81
39D718G010JP4	56289	3	11	LM318H	12040	15	48
39D805G350GE4	56289	3	17	MC858P	04713	15	60
402149	89536	2	10	MC862P	04713	15	61
40372	95303	3	14	MPS6520	04713	15	100
4515PORM20PCT2W	71450	13	51	MS51957-26	96906	15	56
55C23A1	56289	9	47	PME75	03888	15	11
55C23A1	56289	13	22	RCR07G102JS	81349	15	84
583257	00779	13	18	RCR07G104JS	81349	15	25
583527	00779	14	6	RCR07G105JS	81349	15	36
583529	00779	13	34	RCR07G123JS	81349	15	54
5836502	00779	13	8	RCR07G184JS	81349	15	58
5836509	00779	13	11	RCR07G203JS	81349	15	68
60994	95303	3	1	RCR07G204JS	81349	15	108
60994	95303	13	14	RCR07G220JS	81349	15	26
6203M5	00334	2	8	RCR07G223JS	81349	15	40
7001	05704	11	3	RCR07G302JS	81349	15	46
765972	15898	8	24	RCR07G304JS	81349	15	41
82045	32767	11	12	RCR07G330JS	81349	15	83
82045	32767	12	5	RCR07G391JS	81349	15	55
82055	32767	11	13	RCR07G392JS	81349	15	112
82055	32767	12	6	RCR07G470JS	81349	15	91
82065	32767	11	10	RCR07G473JS	81349	15	59
82065	32767	12	4	RCR07G474JS	81349	15	106
848635C	00779	10	27	RCR07G512JS	81349	15	111
86144-2	00779	13	58	RCR07G513JS	81349	15	38
863VWR470120VPROM20PCT	84411	8	2	RCR07G560JS	81349	15	78
863VW47391	84411	7	19	RCR07G562JS	81349	15	101
88000	17069	3	24	RCR07G563JS	81349	15	102
88000	17069	6	55	RCR07G680JS	81349	15	66
88000	17069	7	73	RCR07G682JS	81349	15	67
88000	17069	9	42	RCR07G754JS	81349	15	107
88000	17069	13	57	RCR07G823JS	81349	15	57
9102W	28708	2	6	RCR07G912JS	81349	15	103
973102A10SL3PG39	02660	12	8	RNC60H10ROF	09969	15	85
				RNC60H1000FS	81349	15	116
				RNC60H10.05B	81349	15	113
				RNC60H1702F	81349	15	71
				RNC60H3402FS	81349	15	74
				RNC60H3572FS	81349	15	72
				RNC60H4.975K	81349	15	114
				RNC60H4653FS	81349	15	77
				RNC60H4993FS	81349	15	80
				RNC60H5001B	81349	15	115
				RNC60H8871FS	81349	15	69
				RNC60H1003FS	81349	15	70
				RNC60H1.001KB	81349	15	30
				RNC60H1004FS	81349	15	65
				RNC60H4872FS	81349	15	52
				RNC60H5002B	81349	15	51
				RNC60H110.6KF	81349	15	24
<u>LATEST PART NUMBER ASSIGNMENTS</u>							
C280AEA22K	73445	15	97				
C280AEA33K	34553	15	35				
C280AEA47K	73445	15	45				
C280AEA4K7	34553	15	109				
C280AEA6K8	34553	15	93				
DHD1105	03508	15	33				
DME15E27J	72915	15	75				
DM15C101K	72915	15	44				
DM15C15J	72915	15	43				
DM15C2D	72915	15	47				
DM15E33J	72915	15	79				
DM15F100J	72915	15	27				
DM15F360J	72915	15	28				
DM15F390J	72915	15	86				

HISA-FM 2883-2-74

SECTION VI. NATIONAL STOCK NUMBER AND PART NUMBER INDEX (CONTINUED)

PART NUMBER	FSCM	FIG. NO.	ITEM NO.	PART NUMBER	FSCM	FIG.	ITEM
RN65D9953B	81349	15	23				
RN65D2004F	81349	15	94				
SF50070	12040	15	37				
SG-8023	34333	15	110				
SL-841-777	12615	15	9				
SST1MC	06383	15	3				
TCR5309	07910	15	105				
TD12599	07910	15	82				
VY10CA2R2CA	95275	15	18				
VY10CA2R7CA	95275	15	14				
VY10CA27OJA	95275	15	22				
1N270	99180	15	62				
1N754A	81349	15	13				
1N961A	81349	15	99				
1497B	88245	15	4				
150D15X9020B2	56289	15	50				
2N3904	04713	15	42				
2N3906	81349	15	39				
2N5078	81349	15	16				
2N5197	81349	15	49				
23021	10389	15	63				
26018D	05820	15	89				
272070	89536	15	53				
284091	89536	15	6				
269019	89536	15	7				
280008	89536	15	32				
98	89536	15	31				
304048	89536	15	2				
313833	89536	15	8				
3329HJ81-3R0	80294	15	96				
3386RM09-050	80294	15	64				
3386RM09-101	80294	15	117				
3386RM09-102	80294	15	20				
3386RM09-103	80294	15	17				
3386RM09-105	80294	15	15				
339366	89536	15	119				
345561	89536	15	118				
360T105A	11236	15	92				
361048	89536	15	KIT				
406199	89536	15	1				
530-000	72982	15	10				
538006D935	32897	15	21				

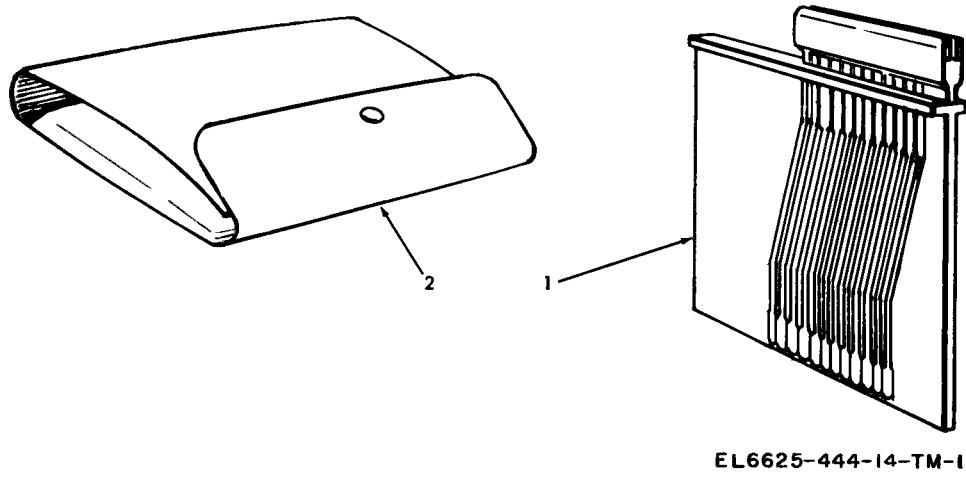
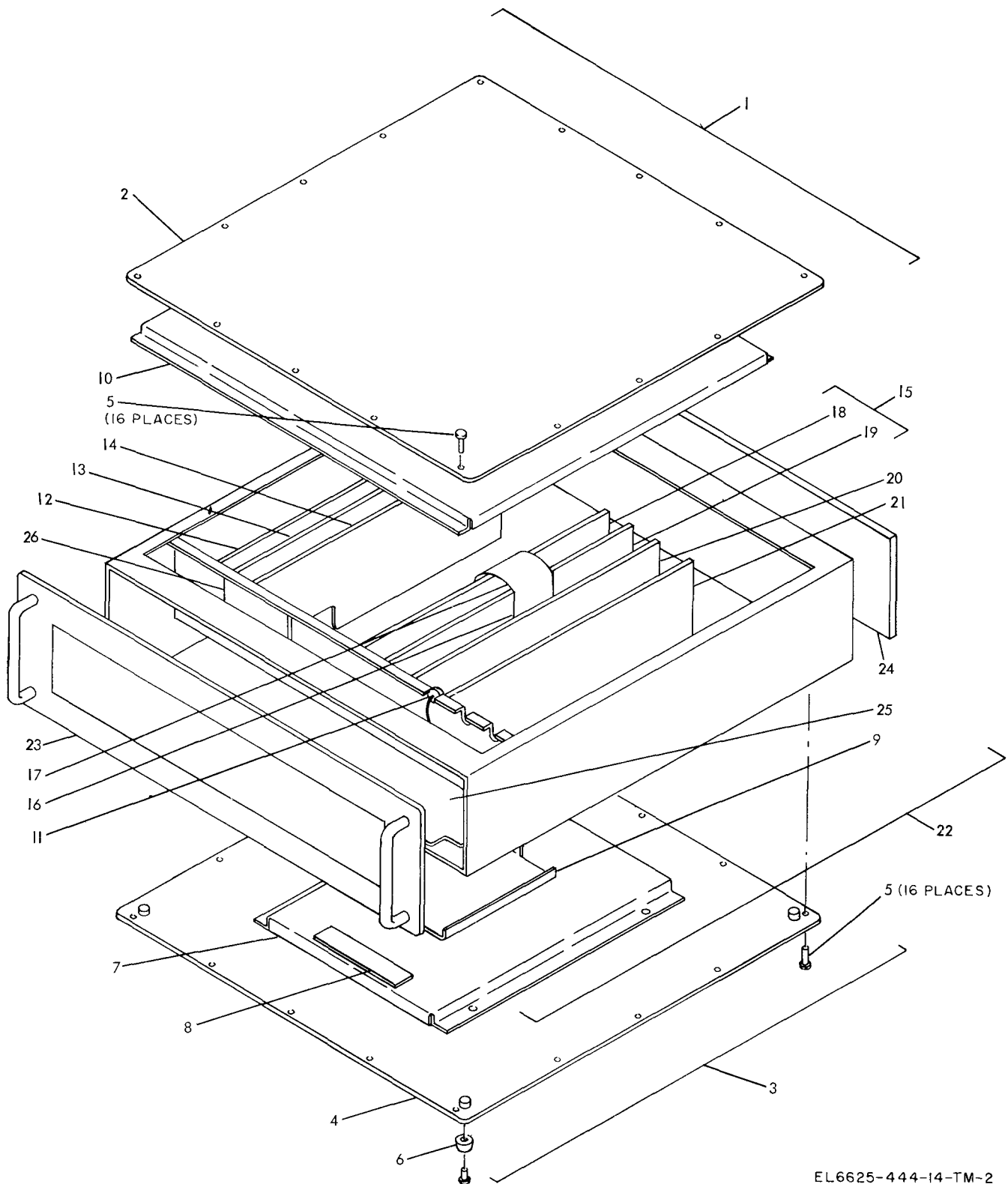

Figure 1. Extender card.



EL6625-444-14-TM-2

Figure 2. Digital Voltmeter AN/GSM-64B.

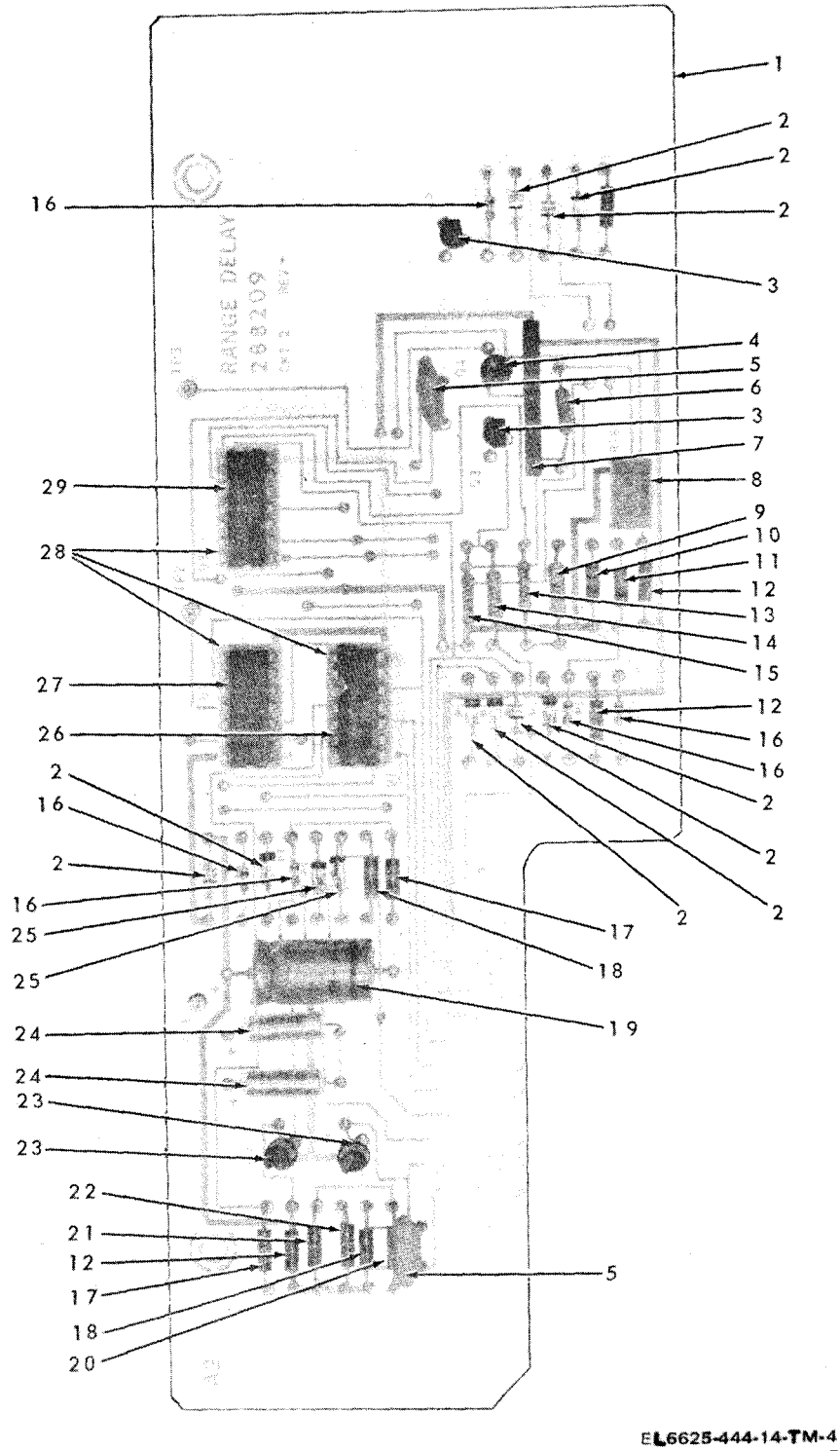
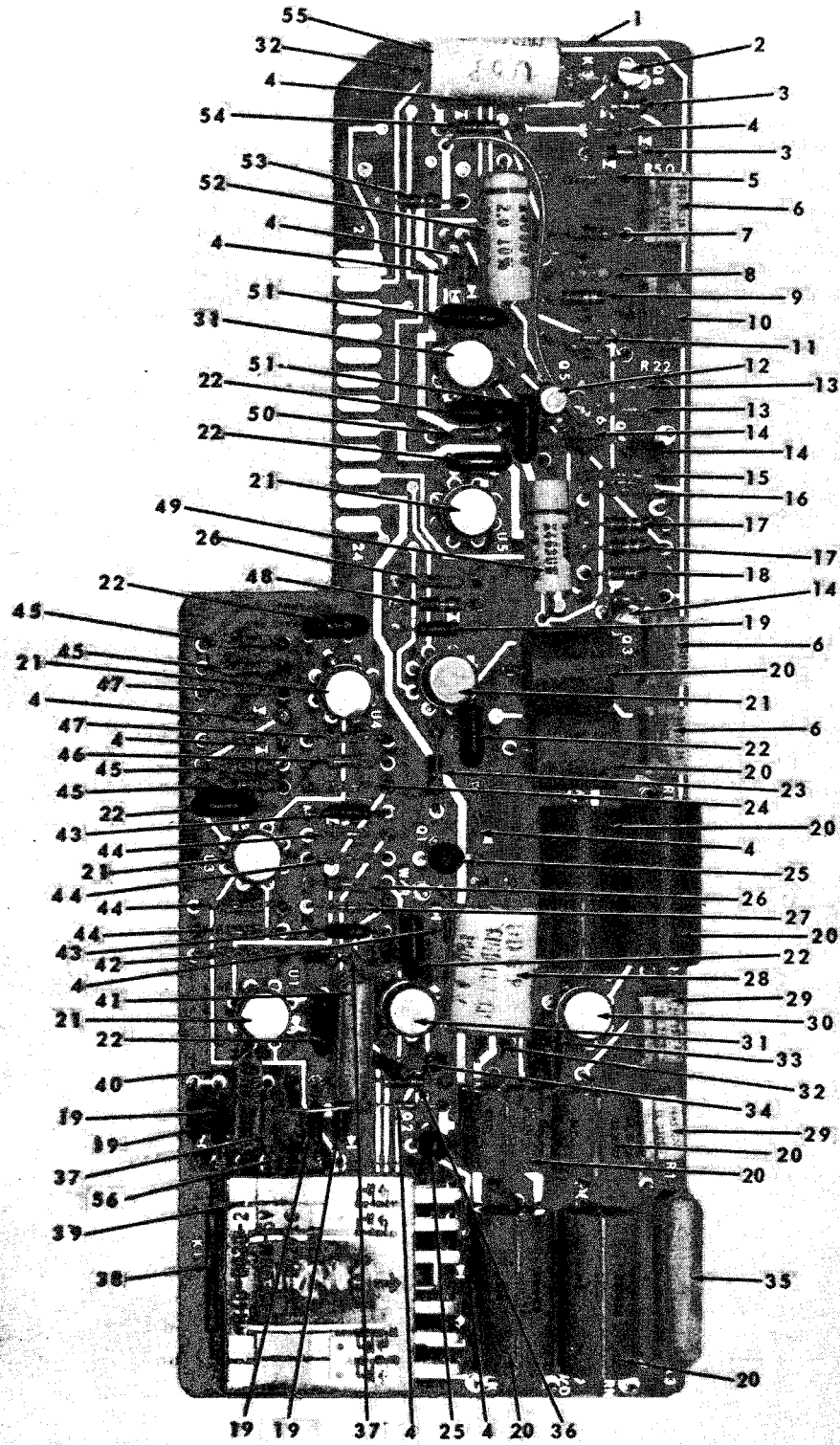
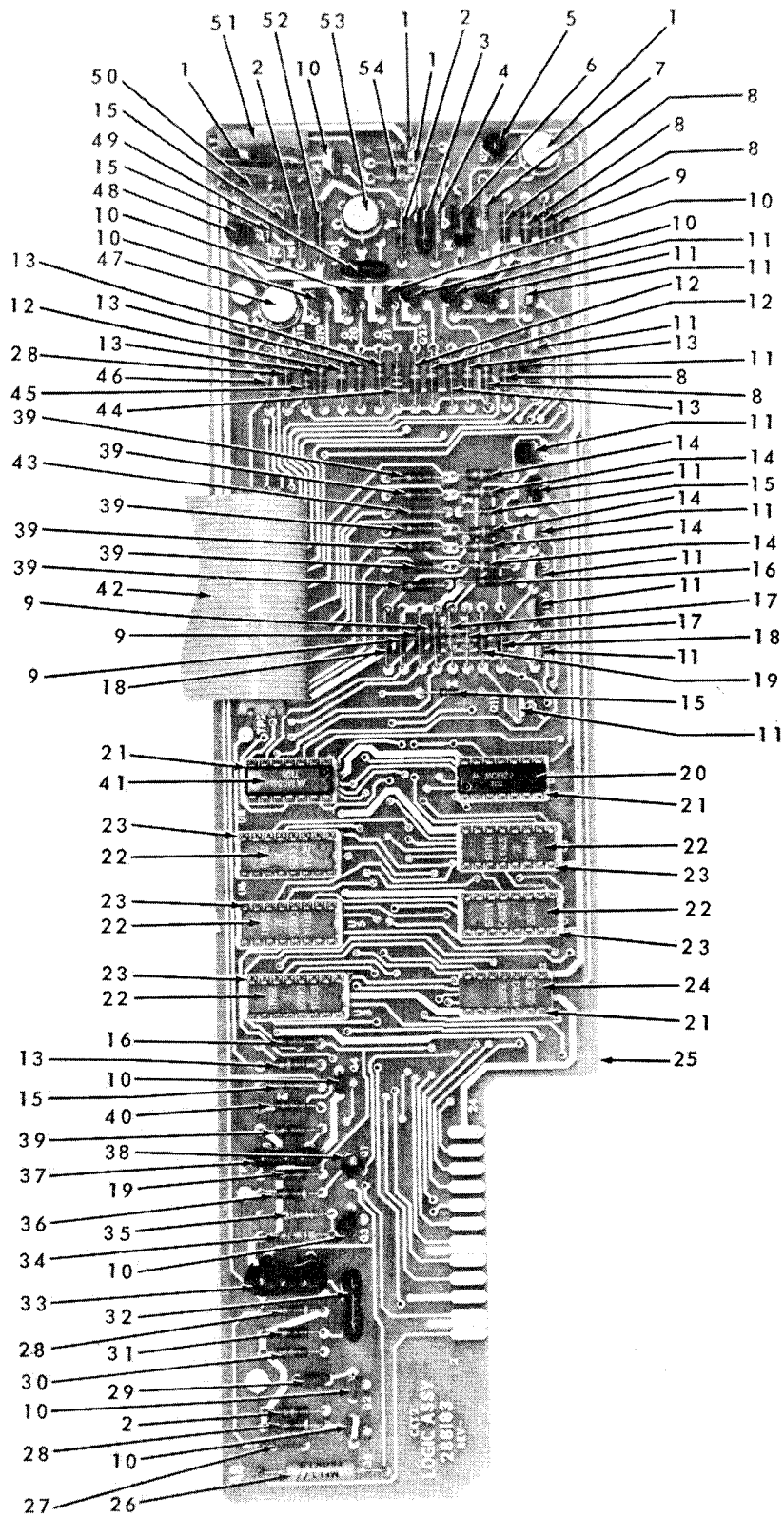

Figure 4. Range delay assembly



EL6625-444-14-TM-6

Figure 5. Ratio input assembly.



EL6625-444-14-TM-6

Figure 6. Logic assembly.

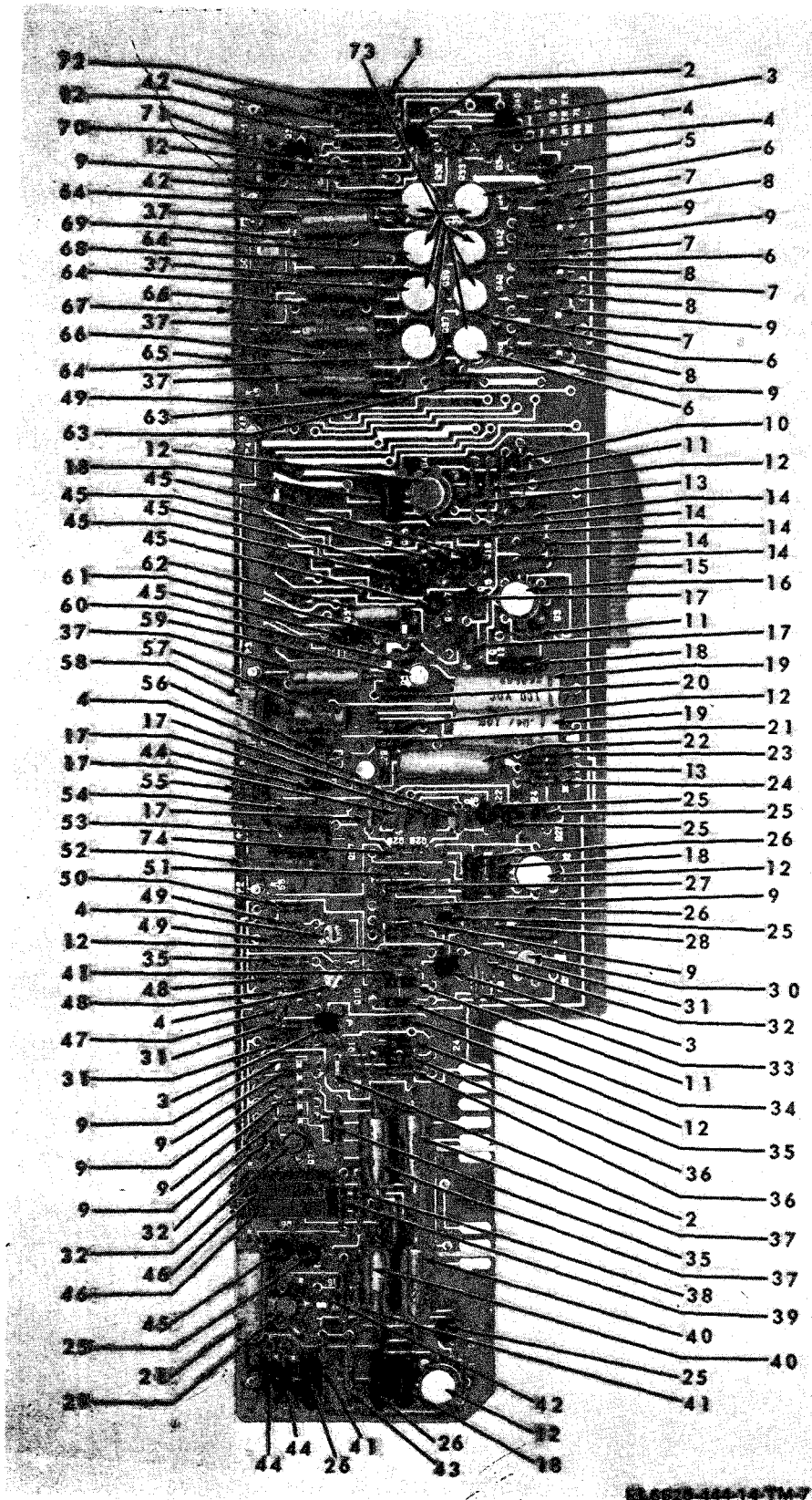
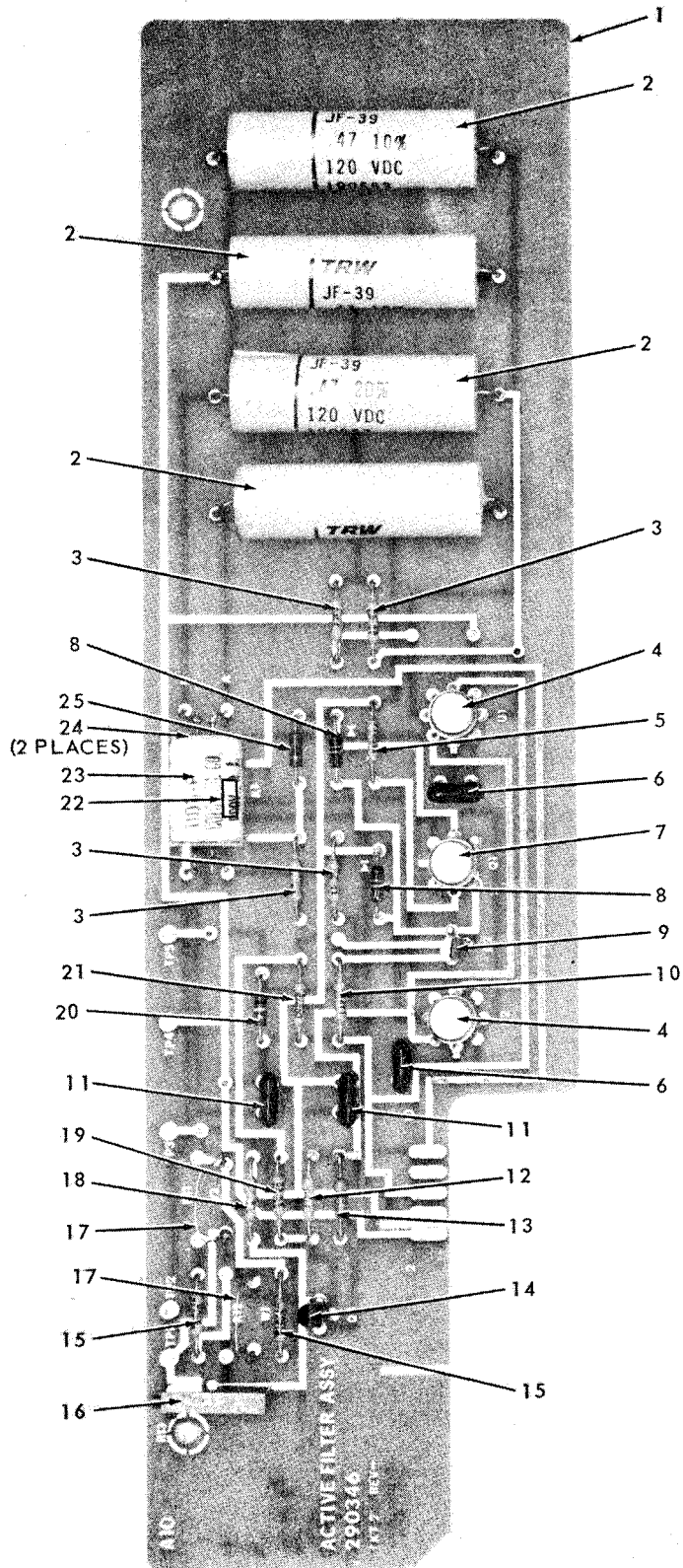

Figure 7. A-to-D converter assembly.



EL6625-444-14-TM-8

Figure 8. Active filter assembly.

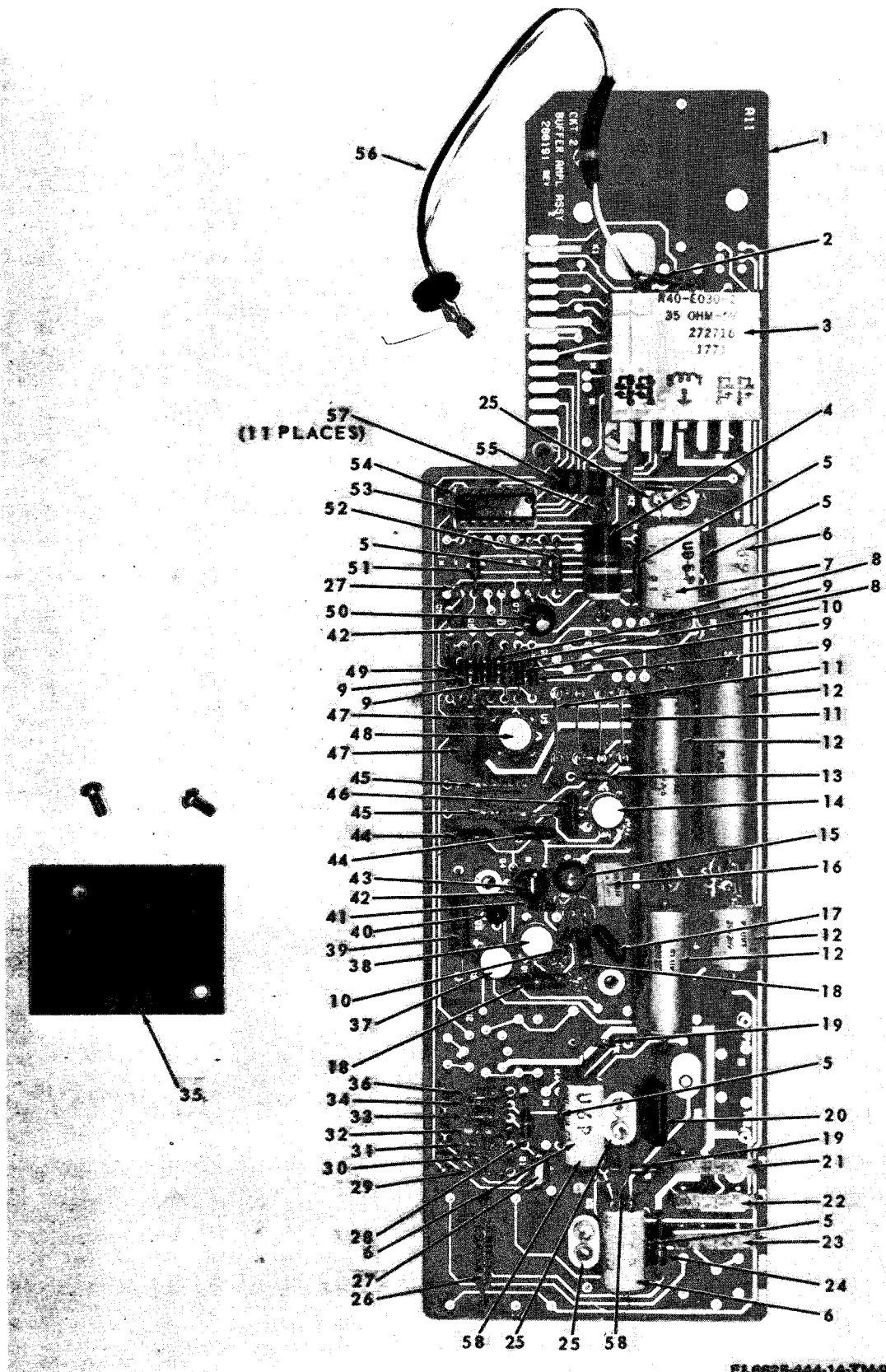
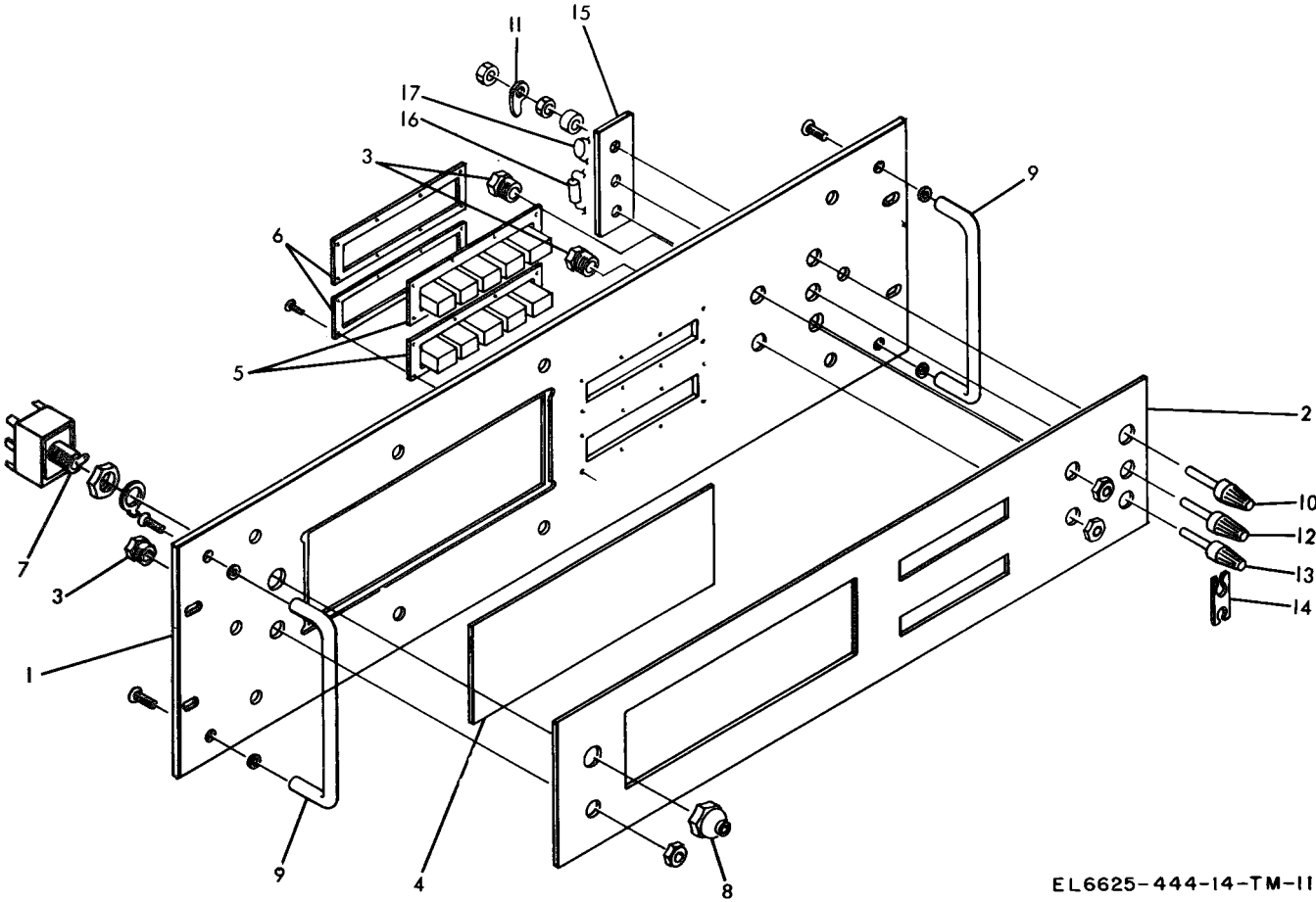
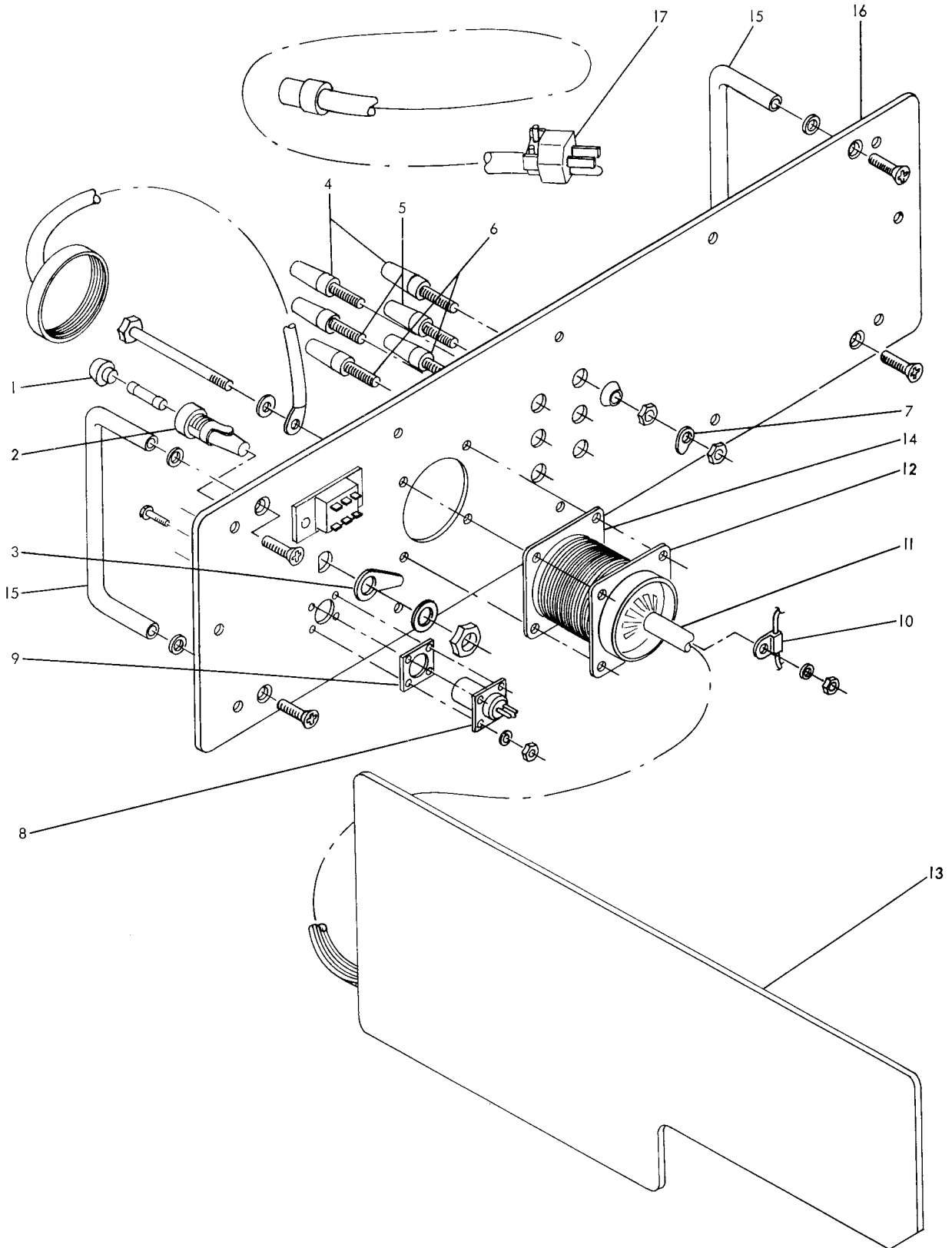

Figure 9. Buffer amplifier assembly.



EL6625-444-14-TM-11

Figure 11. Front panel assembly.



EL6625-444-14-TM-12

Figure 12. Rear assembly.

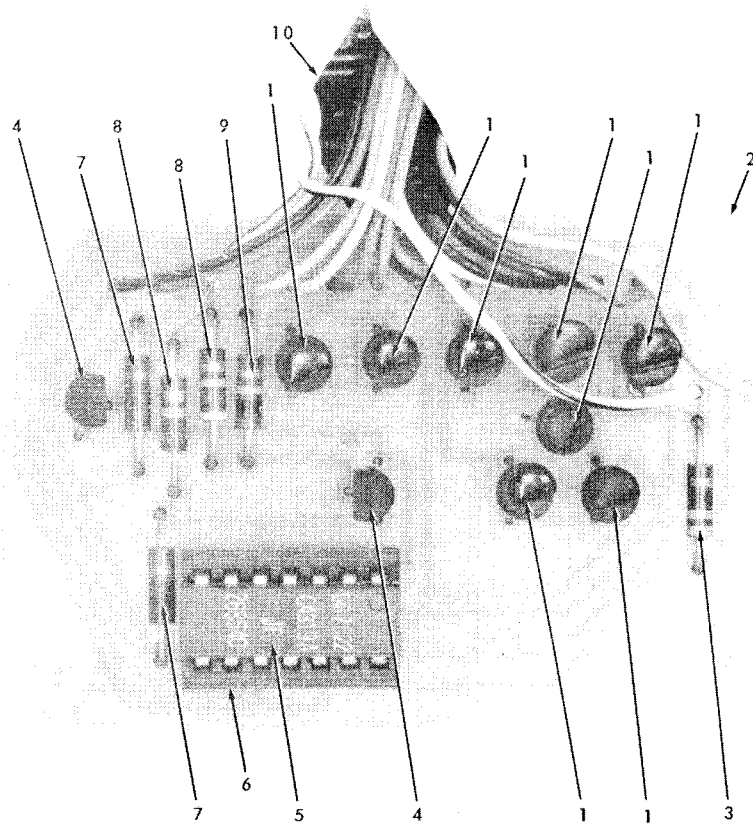

EL6625-444-14-TM-14

Figure 14. Decimal logic assembly.

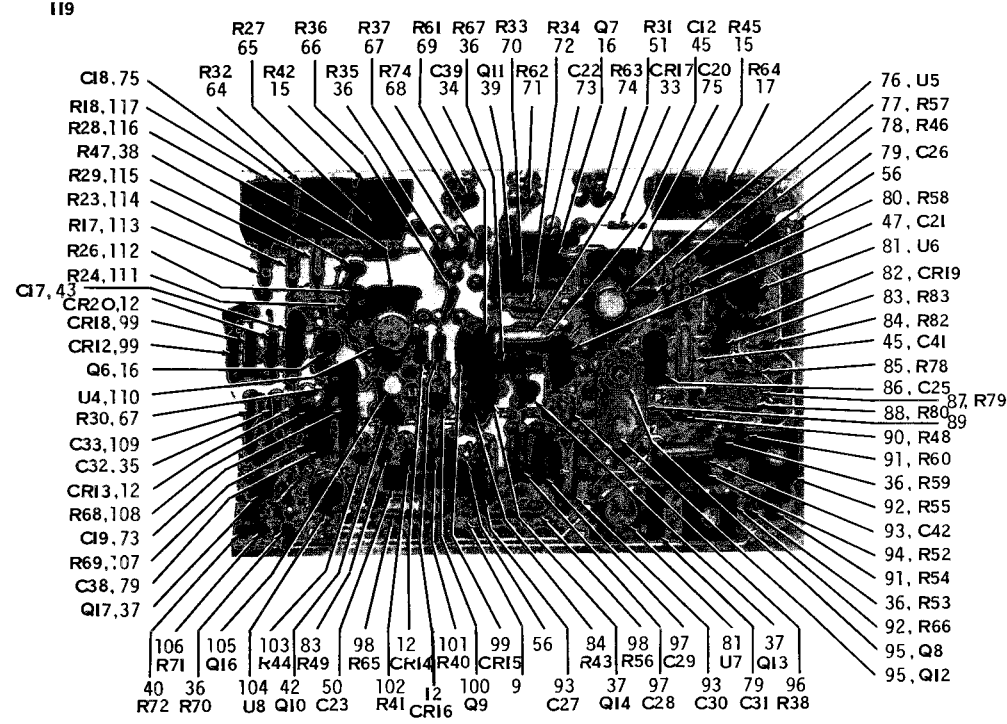
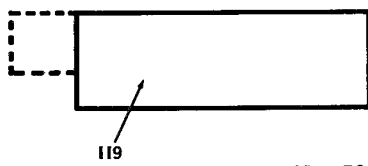
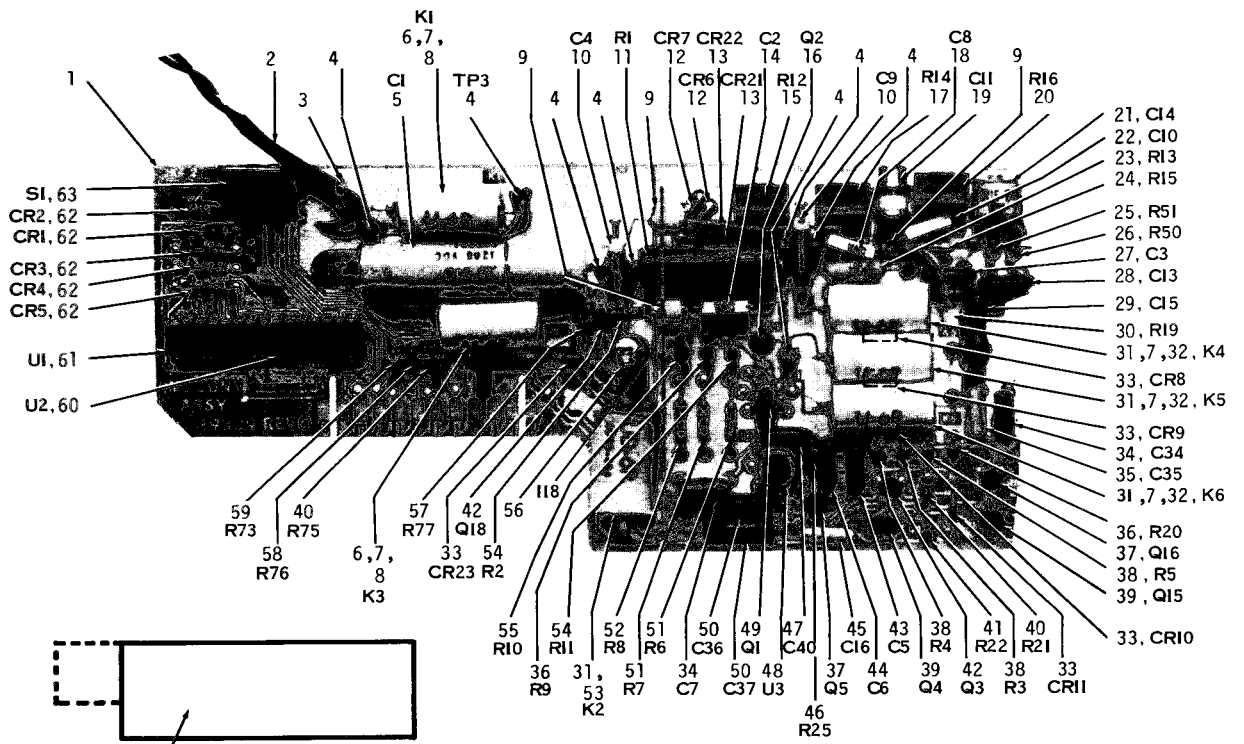

ELOFF005

B-15. Ac converter assembly

APPENDIX C

MAINTENANCE ALLOCATION

Section I. INTRODUCTION

C-1. General

This appendix provides a summary of the maintenance operations for AN/GSM-64B. It authorizes categories of maintenance for specific maintenance functions on repairable items and components and the tools and equipment required to perform each function. This appendix may be used as an aid in planning maintenance operations.

C-2. Maintenance Function

Maintenance functions will be limited to and defined as follows:

a. Inspect. To determine the serviceability of an item by comparing its physical, mechanical, and/or electrical characteristics with established standards through examination.

b. Test. To verify serviceability and to detect incipient failure by measuring the mechanical or electrical characteristics of an item and comparing those characteristics with prescribed standards.

c. Service. Operations required periodically to keep an item in proper operating condition; i.e., to clean, preserve, drain, paint, or to replenish fuel/lubricants/hydraulic fluids or compressed air supplies.

d. Adjust. Maintain within prescribed limits by bringing into proper or exact position, or by setting the operating characteristics to the specified parameters.

e. Align. To adjust specified variable elements of an item to about optimum or desired performance.

f. Calibrate. To determine and cause corrections to be made or to be adjusted on instruments or test measuring and diagnostic equipment used in precision measurement. Consists of the comparison of two instruments, one of which is a certified standard of known accuracy, to detect and adjust any discrepancy in the accuracy of the instrument being compared.

g. Install. The act of emplacing, seating, or fixing into position an item, part, module (component or assembly) in a manner to allow the proper functioning of the equipment/system.

h. Replace. The act of substituting a serviceable like-type part, subassembly, module (component or assembly) for an unserviceable counterpart.

i. Repair. The application of maintenance services (inspect, test, service, adjust, align, calibrate, replace) or other maintenance actions (welding, grinding, riveting, straightening, facing, remachining, or resurfacing) to restore serviceability to an item by correcting specific damage, fault, malfunction, or failure in a part, subassembly, module/component/assembly, end item or system.

j. Overhaul. That periodic maintenance effort (service/action) necessary to restore an item to a completely serviceable/operational condition as prescribed by maintenance standards (e.g., DWR) in appropriate technical publications. Overhaul is normally the highest degree of maintenance performed by the Army. Overhaul does not normally return an item to like-new condition.

k. Rebuild. Consists of those services/actions necessary for the restoration of unserviceable equipment to a like-new condition in accordance with original manufacturing standards. Rebuild is the highest degree of materiel maintenance applied to Army equipment. The rebuild operation includes the act of returning to zero those age measurements (hours, miles, etc.) considered in classifying Army equipment/components.

C-3. Column Entries

a. Column 1, Group Number. Column 1 lists group numbers, the purpose of which is to identify components, assemblies, subassemblies, and module with the next higher assembly.

b. Column 2, Component/Assembly. Column 2 contains the noun names of components, assemblies, subassemblies, and modules for which maintenance is authorized.

c. Column 3, Maintenance Functions. Column 3 lists the functions to be performed on the item listed in column 2.

d. Column 4, Maintenance Category. Column 4

specifies, by the listing of a "worktime" figure in the appropriate subcolumn(s), the lowest level of maintenance authorized to perform the function listed in column 3. This figure represents the active time required to perform that maintenance function at the indicated category of maintenance. If the number or complexity of the tasks within the listed maintenance function vary at different maintenance categories, appropriate "worktime" figures will be shown for each category. The number of man-hours specified by the "worktime" figure represents the average time required to restore an item (assembly, subassembly, component, module, end item or system) to a serviceable condition under typical field operating conditions. This time includes preparation time, troubleshooting time, and quality assurance/quality control time in addition to the time required to perform the specific tasks identified for the maintenance functions authorized in the maintenance allocation chart.

e. Column 5, Tools and Equipment. Column 5 specifies by code, those common tool sets (not individual tools) and special tools, test, and

support equipment required to perform the designated function.

C-4. Tool and Test Equipment Requirements

a. Tool or Test Equipment Reference Code. The numbers in this column coincide with the numbers used in the tools and equipment column of the MAC. The numbers indicate the applicable tool or test equipment for the maintenance functions.

b. Maintenance Category. The codes in this column indicate the maintenance category allocated the tool or test equipment.

c. Nomenclature. This column lists the noun name and nomenclature of the tools and test equipment required to perform the maintenance functions.

d. National / NATO Stock Number. This column lists the National/NATO stock number of the specific tool or test equipment.

e. Tool Number. This column lists the manufacturer's part number followed by the Federal supply code for manufacturer (5-digit) in parentheses.

(Next printed page is C-3)

SECTION II MAINTENANCE ALLOCATION CHART
FOR

DIGITAL VOLTMETER AN/GSM-64B INCLUDING
PLUG-IN, ELECTRONIC TEST EQUIPMENT TYPE 1370/GSM-64B

(1) GROUP NUMBER	(2) COMPONENT/ASSEMBLY	(3) MAINTENANCE FUNCTION	(4) MAINTENANCE CATEGORY					(5) TOOLS AND EQUIPMENT
			C	O	F	H	D	
0101	DIGITAL VOLTMETER AN/GSM-64B	Inspect Service Test Adjust Repair Overhaul		1.0 1.0		4.7 1.0 11.0	15.0	8 8 5 5 5 5
0102	POWER SUPPLY ASSEMBLY	Test				0.5		1,5
0103	RANGE SUPPLY ASSEMBLY	Test Repair				0.2 0.5		2,4,5 3,
0104	RATIO INPUT ASSEMBLY	Test Adjust Repair				0.5 0.5 1.0		1,2,4,5 1,2,4,5 3,
0105	LOGIC PCB	Test Repair				0.5 1.0		2,4,5 3
0106	A-D CONVERTER ASSEMBLY	Test Adjust Repair				0.5 0.2 1.0		2,3,5 2,4,5 3
0107	ACTIVE FILTER ASSEMBLY	Test Repair				0.5 1.0		4,5,9 3
0108	BUFFER ASSEMBLY	Test Adjust Repair				0.5 0.5 1.5		4,5,6,7 4,5,6,7 3
0109	FINAL ASSEMBLY	Repair Overhaul				2.0	4.0	3 3,8
0110	FRONT PANEL ASSEMBLY	Replace Repair				0.5 1.0		3 3
0111	REAR PANEL ASSEMBLY	Replace Repair				0.8 1.2		3 3
0112	DISPLAY ASSEMBLY	Test Replace Repair				0.5 0.2 0.5		2,4,5 3 3
0113	DECIMAL LOGIC ASSEMBLY	Test Repair				1.0 1.4		2,4,5 3
0114	PLUG-IN, ELECTRONIC TEST EQUIPMENT PL-1370/GSM-64B	Test Adjust Replace Repair				0.5 0.3 2.2	1.0	2,3,5,9 2,3,5,9 3 3

Change 1 C-3

TABLE J. TOOL AND TEST EQUIPMENT REQUIREMENTS FOR

DIGITAL VOLTMETER AN/GSM-6LR INCLUDING
 PLUG-IN, ELECTRONIC TEST EQUIPMENT PI-1370/GSM-6LR

TOOL OR TEST EQUIPMENT REF. CODE	MAINTENANCE CATEGORY	NOMENCLATURE	ADDITIONAL NATO STOCK NUMBER	TOOL NUMBER
	I,D	MULTIMETER TS-352B/U	6625-00-553-0142	
	H,D	OSCILLOSCOPE AN/USM-281A	6625-00-328-2201	
	H,D	TOOL KIT ELECTRONIC EQUIPMENT TK-100/G	3180-00-605-0079	
	H,D	D.C. VOLTAGE CALIBRATOR JOHN FLUKE MDL 332A9	6625-00-239-8921	
	H,D	DIFFERENTIAL VOLTMETER (BATT) AN/USM-98	6625-00-753-2111	
6	H,D	RESISTOR, 1 MEG $\pm 5\%$, 1/4 W		
	H,D	CAPACITOR, 22UF, 100V		
8	O,H,D	TOOLS & TEST EQUIPMENT NORMALLY USED BY MAINTENANCE PERSONNEL BECAUSE OF ASSIGNED MISSION		
9	H,D	METER TEST SET TS-682	6625-00-669-0714	

INDEX

	Paragraph	Page		Paragraph	Page
Alignment	6-17	6-28	Maintenance, organizational:		
Assembly	6-13	6-26	Cleaning	4-9	4-3
Ac converter	7-2		Functional testing	4-10	4-3
Bench-top use	2-4	2-4	General	4-1.4-74-1,	4-3
Block diagram analysis:			Materials required	4-2	4-1
Dc measurement mode	5-2	5-1	Preventive maintenance	4-4	4-1
Introduction	5-1	5-1	Removal/replacement	4-8	4-3
Ratio mode	5-3	5-2	Operation:		
Checking unpacked equipment	2-2	2-1	Dc ratio measurement	3-9	3-6
Circuit description:			Dc voltage measurement	3-9	3-6
Ac converter	7-12		Initial adjustments	3-7	3-5
A/D converter and logic	5-7	5-5	Preliminary starting procedure	3-6	3-5
Active filter	5-6	5-5	Printer output use	3-10	3-7
Buffer	5-5	5-4	Shutdown	3-12	3-7
Decimal logic	5-12	5-16	Standby-operation	3-11	3-7
Display	5-8	5-12	Operator controls	3-4	3-2
Introduction	5-4	5-4	Performance testing	6-16	6-27
Power supply	5-10	5-15	PL-1370/GSM-64B:		
Range delay	5-9	5-14	Ac measurements	7-9	7-3
Ratio input	5-11	5-16	Block diagram description	7-11	7-3
Component selection	6-14	6-26	Circuit description	7-12	7-5
Dc voltage measurement	3-8	3-5	Circuit isolation	7-16	7-8
Dc ratio measurement	3-9	3-6	Description	7-3	7-1
Description	1-6	1-2	General support testing	7-18	7-9
Forms and records	1-3	1-1	Initial adjustments	7-8	7-3
General:			Installation instructions	7-5	7-2
Controls and instruments	3-1	3-1	Introduction	7-10	7-3
Fault isolation	6-7a	6-15	Matched set replacement	7-17	7-9
Gs maintenance	6-9	6-23	Performance check	7-14	7-6
Maintenance	4-7	4-3	Precautions and operator controls	7-6	7-2
Operation	3-5	3-5	Preliminary starting procedures	7-7	7-3
Preventive maintenance checks and services	4-4	4-1	Purpose and use	7-2	7-1
Shipment	3-13	3-7	Removal and replacement	7-13	7-6
Tools and equipment	4-1	4-1	Scope	7-1	7-1
Troubleshooting	4-5	4-2	Technical characteristics	7-4	7-1
Indexes of publications	1-2	1-1	Voltage measurements	7-15	7-6
Initial adjustments	3-6	3-5	Printer output use	3-10	3-7
Installation, rack mount	2-3	2-2	Purpose and use	1-5	1-1
Maintenance, general support:			Recommendation for maintenance publication improvements	1-4	1-1
Analog section troubleshooting	6-8	6-22	Repair and replacement	6-12	6-25
Assembly	6-13	6-26	Scope	1-1	1-1
Cleaning	6-11	6-25	Shipment:		
Component section	6-14	6-26	Bench/shelf movement	3-15	3-7
Disassembly	6-10	6-23	Rack removal	3-14	3-7
Fault isolation	6-7	6-15	Shutdown procedures	3-12	3-7
Introduction	6-1	6-1	Standby operations	3-11	3-7
Maintenance, general	6-9	6-23	Starting procedures, preliminary	3-6	3-5
Parts location	6-4	6-3	Technical characteristics	1-7	1-2
Schematic diagrams	6-3	6-3	Testing:		
Testing procedures:			Alignment	6-17	6-28
Alignment	6-17	6-28	Performance	6-16	6-27
Performance	6-16	6-27	Troubleshooting:		
Tools and test equipment	6-5	6-15	Analog section	6-8	6-22
Troubleshooting instructions	6-6	6-15	General	4-5	4-2
Voltage and waveform diagrams	6-2	6-1	Procedure	4-6	4-2
			Section fault isolation	6-7	6-15
			Unpacking	2-1	2-1

By Order of the Secretary of the Army:

Official:

VERNE L. BOWERS

*Major General, United States Army,
The Adjutant General.*

FRED C. WEYAND

*General, United States Army,
Chief of Staff.*

Distribution:

Active Army:

USASA (2)	WSMR (1)
Dir of Trans (1)	Fort Carson (5)
COE (1)	Fort Gillem (10)
TSG (1)	Ft Richardson (ECOM Ofc) (2)
USAARENBD (1)	Army Dep (1) except
AMC (1)	LBAD (14)
TRADOC (2)	SAAD (30)
ARADCOM (2)	TOAD (14)
AR ADCOM Rgn (2)	USA Dep (2)
OS Maj Comd (4)	Sig Sec USA Dep (2)
LOGCOMDS (3)	Sig Dep (2)
MICOM (2)	SigFLDMS (1)
TECOM (2)	USAERDAA (1)
USACC (4)	USAERDAW (1)
MDW (1)	MAAG (1)
Armies (2)	USARMIS (1)
Corps (2)	Units org under fol TOE
HISA (Ft Monmouth) (43)	(1 copy each unit):
Svc Colleges (1)	11-96
USACES (1)	11-97
USASESS (5)	11-98
USAADS (2)	11-117
USAFAS (2)	11-127
USAARMS (2)	11-500(AA-AC)
USAIS (2)	29-134
USAES (2)	29-136
USAINTCS (3)	29-402
WRAMC (1)	44-545
ATS (1)	44-546
Fort Gordon (10)	44-547
Fort Huachuca (10)	44-568

NG: None.

USAR: None.

For explanation of abbreviations used, see AR 310-50.

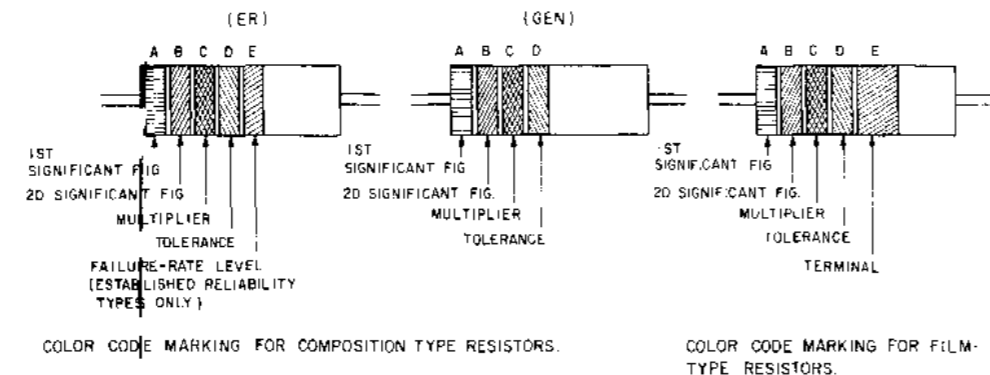

TABLE 1
COLOR CODE FOR COMPOSITION TYPE AND FILM TYPE RESISTORS.

BAND A		BAND B		BAND C		BAND D		BAND E	
COLOR	FIRST SIGNIFICANT FIGURE	COLOR	SECOND SIGNIFICANT FIGURE	COLOR	MULTIPLIER	COLOR	RESISTANCE TOLERANCE (PERCENT)	COLOR	FAILURE RATE LEVEL
BLACK	0	BLACK	0	BLACK	1	BROWN	±10 (COMP. TYPE ONLY)	BROWN	M:1.0
BROWN	1	BROWN	1	BROWN	10	RED	±5	RED	P:0.1
RED	2	RED	2	RED	100	ORANGE	±2 (NOT APPLICABLE TO ESTABLISHED RELIABILITY)	ORANGE	R:0.01
ORANGE	3	ORANGE	3	ORANGE	1,000	YELLOW		YELLOW	S:0.001
YELLOW	4	YELLOW	4	YELLOW	10,000	SILVER		WHITE	
GREEN	5	GREEN	5	GREEN	100,000	GOLD			
BLUE	6	BLUE	6	BLUE	1,000,000	RED			
PURPLE (VIOLET)	7	PURPLE (VIOLET)	7						
GRAY	8	GRAY	8	SILVER	0.01				
WHITE	9	WHITE	9	GOLD	0.1				

BAND A — THE FIRST SIGNIFICANT FIGURE OF THE RESISTANCE VALUE (BANDS A THRU D SHALL BE OF EQUAL WIDTH)

BAND B — THE SECOND SIGNIFICANT FIGURE OF THE RESISTANCE VALUE

BAND C — THE MULTIPLIER (THE MULTIPLIER IS THE FACTOR BY WHICH THE TWO SIGNIFICANT FIGURES ARE MULTIPLIED TO YIELD THE NOMINAL RESISTANCE VALUE.)

BAND D — THE RESISTANCE TOLERANCE

BAND E — WHEN USED ON COMPOSITION RESISTORS, BAND E INDICATES ESTABLISHED RELIABILITY FAILURE-RATE LEVEL (PERCENT FAILURE PER 1,000 HOURS) ON FILM RESISTORS, THIS BAND SHALL BE APPROXIMATELY 1/2 TIMES THE WIDTH OF OTHER BANDS, AND INDICATES TYPE OF TERMINAL. RESISTANCES IDENTIFIED BY NUMBERS AND LETTERS (THESE ARE NOT COLOR CODED.)

SOME RESISTORS ARE IDENTIFIED BY THREE OR FOUR DIGIT ALPHA NUMERIC DESIGNATORS. THE LETTER R IS USED IN PLACE OF A DECIMAL POINT WHEN FRACTIONAL VALUES OF AN OHM ARE EXPRESSED. FOR EXAMPLE:

2N7 = 2.7 OHMS 10R = 10.0 OHMS

FOR WIRE-WOUND-TYPE RESISTORS COLOR CODING IS NOT USED, IDENTIFICATION MARKING IS SPECIFIED IN EACH OF THE APPLICABLE SPECIFICATIONS.

EXAMPLES OF COLOR CODING

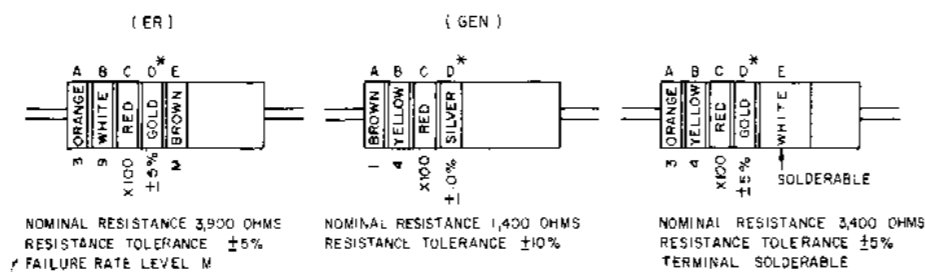

COMPOSITION-TYPE RESISTORS

* IF BAND D IS OMITTED, THE RESISTOR TOLERANCE IS ±20% AND THE RESISTOR IS NOT MIL-STD.

A. COLOR CODE MARKING FOR MILITARY STANDARD RESISTORS.

FILM-TYPE RESISTORS

B. COLOR CODE MARKING FOR MILITARY STANDARD INDUCTORS.

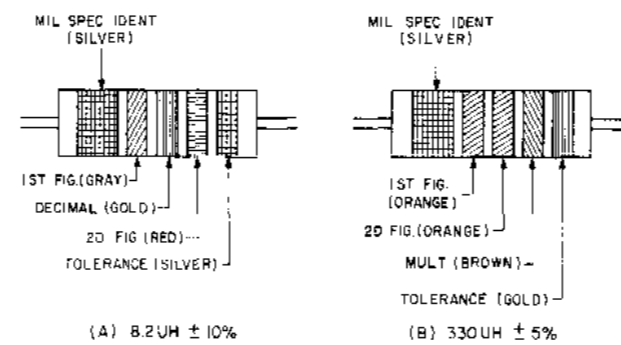

COLOR CODING FOR TUBULAR ENCAPSULATED R.F. CHOKES. AT A, AN EXAMPLE OF THE CODING FOR AN 8.2 UH CHOKES IS GIVEN. AT B, THE COLOR BANDS FOR A 330 UH INDUCTOR ARE ILLUSTRATED.

TABLE 2
COLOR CODING FOR TUBULAR ENCAPSULATED R.F. CHOKES.

COLOR	SIGNIFICANT FIGURE	MULTIPLIER	INDUCTANCE TOLERANCE (PERCENT)
BLACK	0	1	
BROWN	1	10	1
RED	2	100	2
ORANGE	3	1,000	3
YELLOW	4		
GREEN	5		
BLUE	6		
VIOLET	7		
GRAY	8		
WHITE	9		
NONE		20	
SILVER		10	
GOLD	DECIMAL POINT	5	

MULTIPLIER IS THE FACTOR BY WHICH THE TWO COLOR FIGURES ARE MULTIPLIED TO OBTAIN THE INDUCTANCE VALUE OF THE CHOKES COIL.

CAPACITORS, FIXED, VARIOUS-DIELECTRICS, STYLES CM, CN, CY, AND CB.

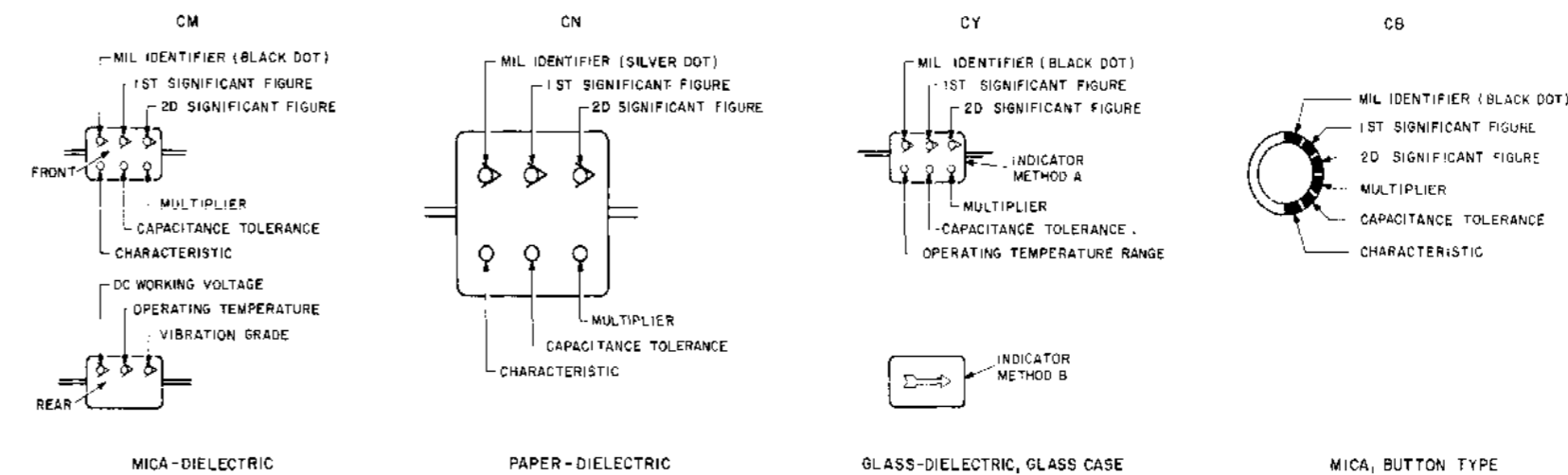

MICA-DIELECTRIC

PAPER-DIELECTRIC

GLASS-DIELECTRIC, GLASS CASE

MICA, BUTTON TYPE

TABLE 3 — FOR USE WITH STYLES CM, CN, CY AND CB.

COLOR	MIL ID	1ST SIG FIG.	2D SIG FIG.	MULTIPLIER	CAPACITANCE TOLERANCE				CHARACTERISTIC	DC WORKING VOLTAGE	OPERATING TEMP RANGE	VIBRATION GRADE
					CM	CN	CY	CB				
BLACK	CM, CY, CB	0	0	1			±20%	±20%				
BROWN		1	1	10					B	E	B	
RED		2	2	100	±2%		±2%	±2%	C			-55° to +85°C
ORANGE		3	3	1,000	±30%				D	D	300	
YELLOW		4	4	10,000					E			-55° to +125°C 10-2,000Hz
GREEN		5	5		±5%				F		500	
BLUE		6	6									-55° to +150°C
PURPLE (VIOLET)		7	7									
GRAY		8	8									
WHITE		9	9									
GOLD				0.1	±5%		±5%					
SILVER	CN			0.01	±10%	±10%	±10%	±10%				

TABLE 4 — TEMPERATURE COMPENSATING, STYLE CC.

COLOR	TEMPERATURE COEFFICIENT*	1ST SIG FIG.	2D SIG FIG.	MULTIPLIER	CAPACITANCE TOLERANCE OVER 10 UUF	CAPACITANCE TOLERANCE 10 UUF OR LESS	MIL ID
BLACK	0	0	0	1		±2.0 UUF	CC
BROWN	-30	1	1	10	±1%		
RED	-80	2	2	100	±2%	±0.25 UUF	
ORANGE	-150	3	3	1,000			
YELLOW	-220	4	4				
GREEN	-330	5	5		±5%	±0.5 UUF	
BLUE	-470	6	6				
PURPLE (VIOLET)	-750	7	7				
GRAY		8	8	0.01*			
WHITE		9	9	0.1*	±10%		
GOLD	+100			0.1		±1.0 UUF	
SILVER				0.01			

1. THE MULTIPLIER IS THE NUMBER BY WHICH THE TWO SIGNIFICANT (SIG) FIGURES ARE MULTIPLIED TO OBTAIN THE CAPACITANCE IN UUF.

2. LETTERS INDICATE THE CHARACTERISTICS DESIGNATED IN APPLICABLE SPECIFICATIONS: MIL-C-5, MIL-C-25D, MIL-C-11272B, AND MIL-C-10590C RESPECTIVELY.

3. LETTERS INDICATE THE TEMPERATURE RANGE AND VOLTAGE-TEMPERATURE LIMITS DESIGNATED IN MIL-C-11015D.

4. TEMPERATURE COEFFICIENT IN PARTS PER MILLION PER DEGREE CENTIGRADE.

* OPTIONAL CODING WHERE METALLIC PIGMENTS ARE UNDESIRABLE.

C. COLOR CODE MARKING FOR MILITARY STANDARD CAPACITORS.

Figure FO-1. Color code-marking for MIL STD resistors, inductors, and capacitors.

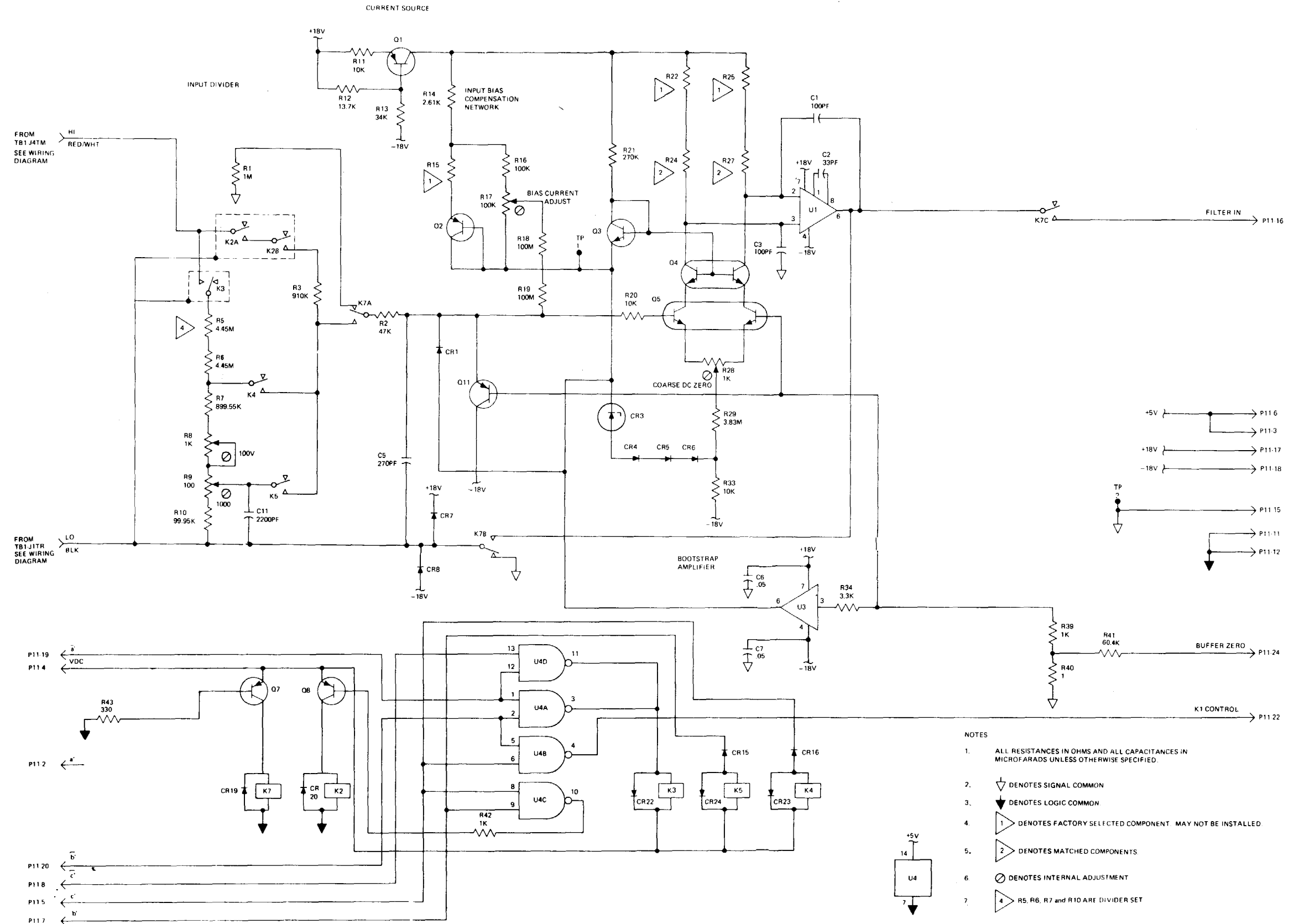

- NOTES
1. ALL RESISTANCES IN OHMS AND ALL CAPACITANCES IN MICROFARADS UNLESS OTHERWISE SPECIFIED.
 2. ▽ DENOTES SIGNAL COMMON
 3. ▽ DENOTES LOGIC COMMON
 4. 1 DENOTES FACTORY SELECTED COMPONENT MAY NOT BE INSTALLED
 5. 2 DENOTES MATCHED COMPONENTS
 6. ⊗ DENOTES INTERNAL ADJUSTMENT
 7. △ R5, R6, R7 and R10 ARE DIVIDER SET

BUFFER RELAY LOGIC

RELAY	VOLTAGE RANGE		
	10	100	1000
K2	*	*	*
K3		*	*
K4		*	*
K5		*	*
K7	*	*	*

* INDICATES RELAY ENERGIZED

Figure FO-2. Buffer (A11) schematic diagram.

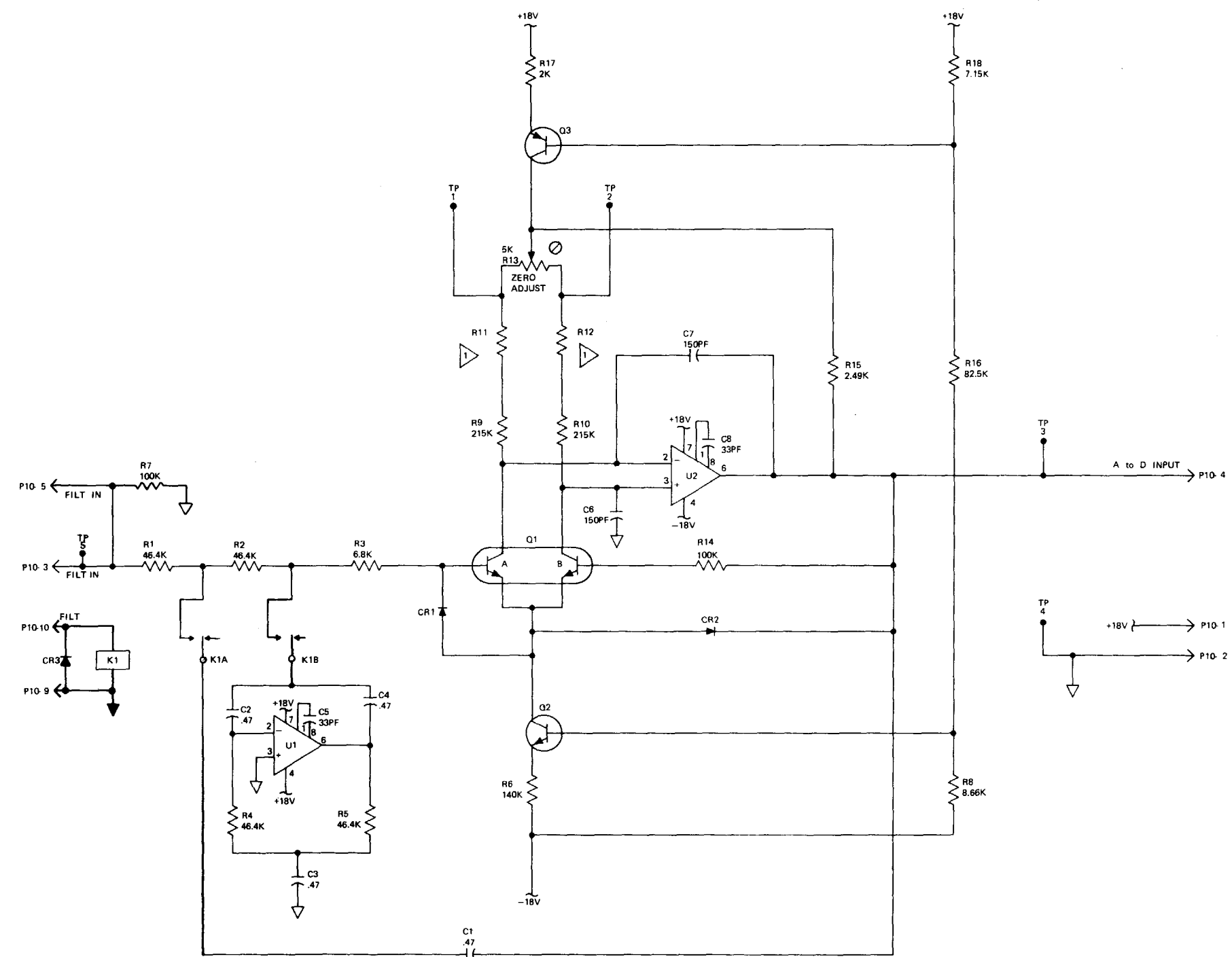

- NOTES
1. ALL RESISTANCES IN OHMS AND ALL CAPACITANCES IN MICROFARADS UNLESS OTHERWISE SPECIFIED.
 2. ▽ DENOTES SIGNAL COMMON.
 3. ▼ DENOTES LOGIC COMMON.
 4. ▢ FACTORY SELECTED.
 5. ○ DENOTES INTERNAL ADJUSTMENT.

Figure FO-3. Active filter (A10) schematic diagram.

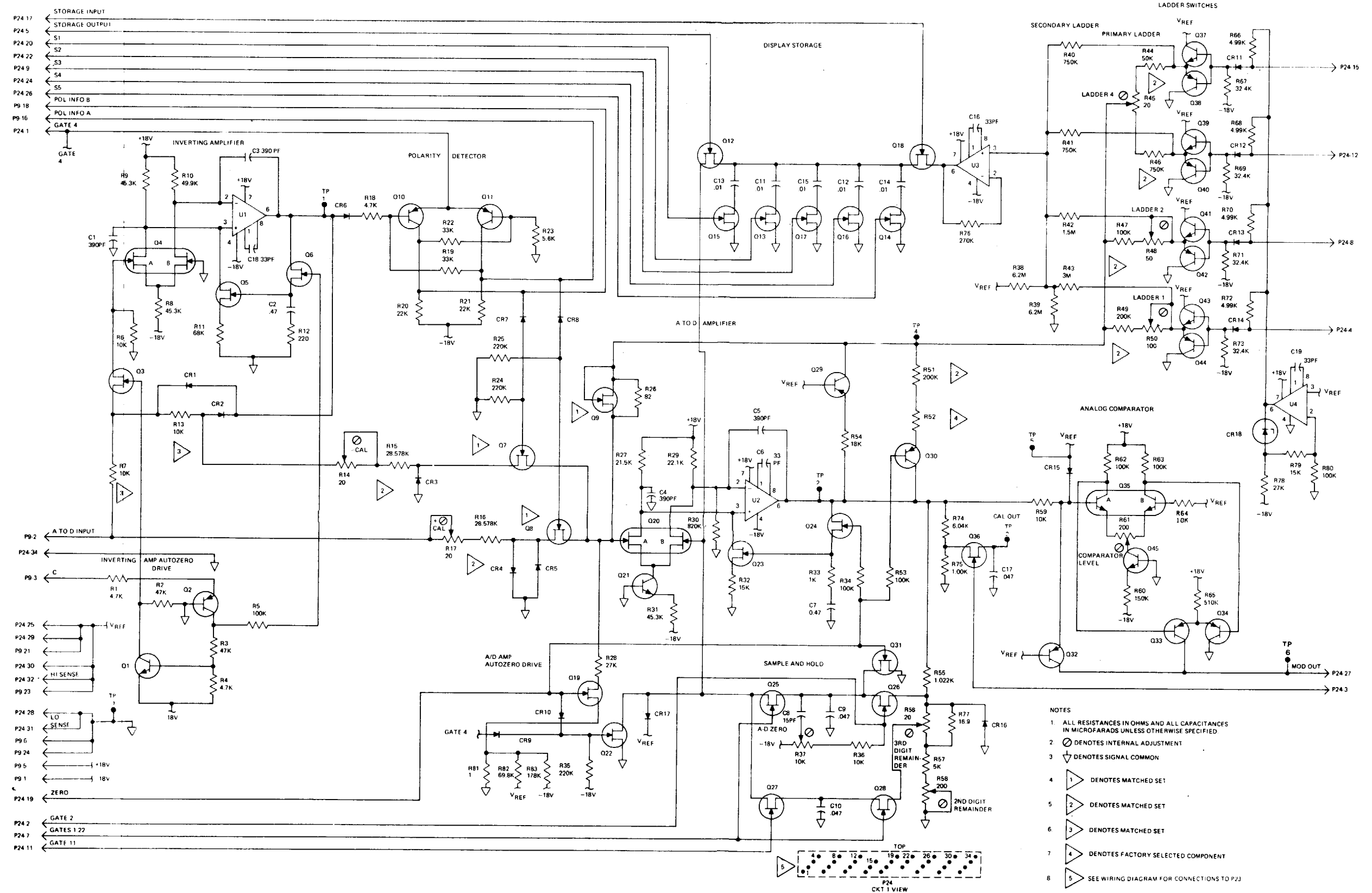

Figure FO-4. A-to-D converter (A9) schematic diagram.

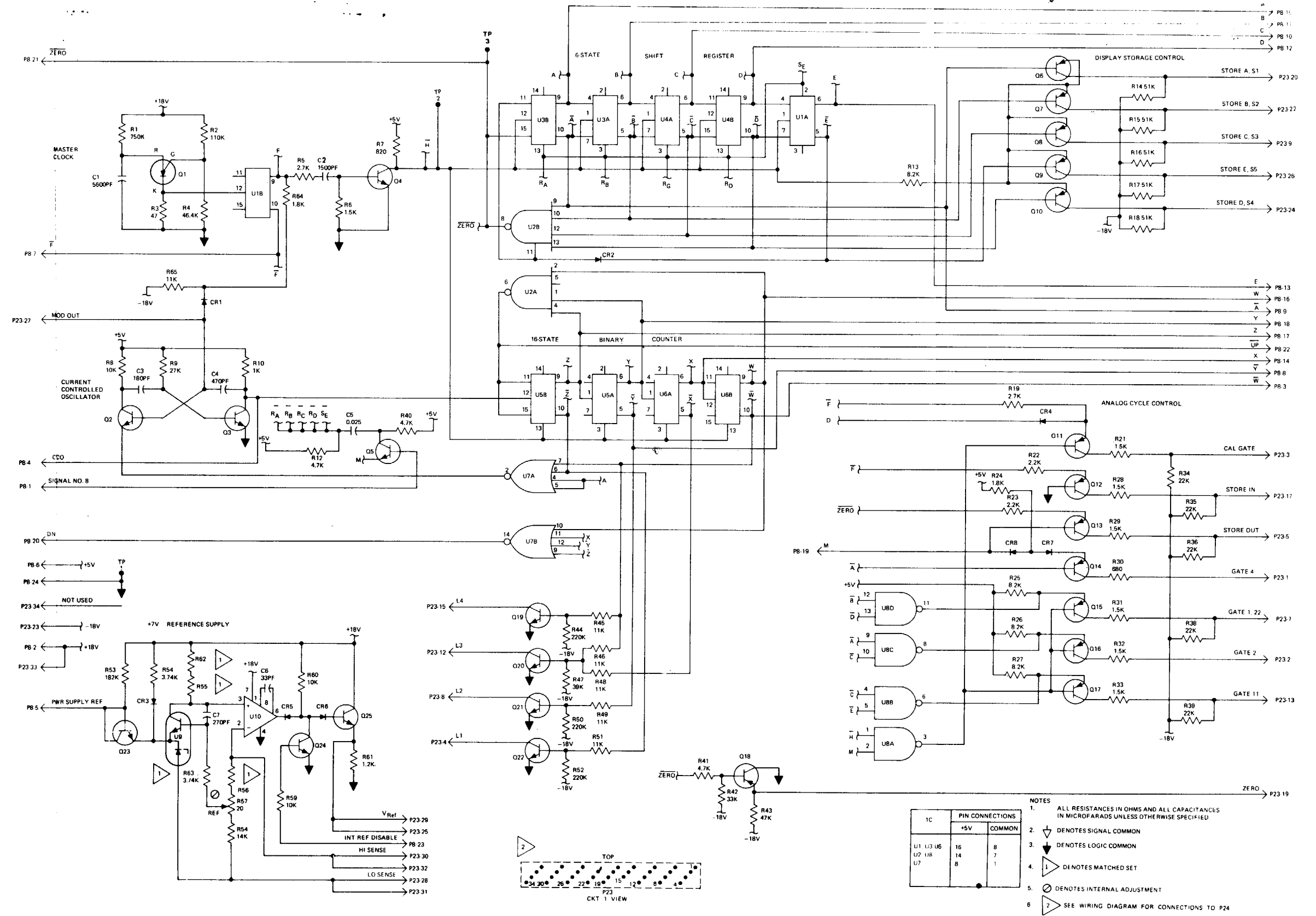

Figure FO-5. Logic (A8) schematic diagram.

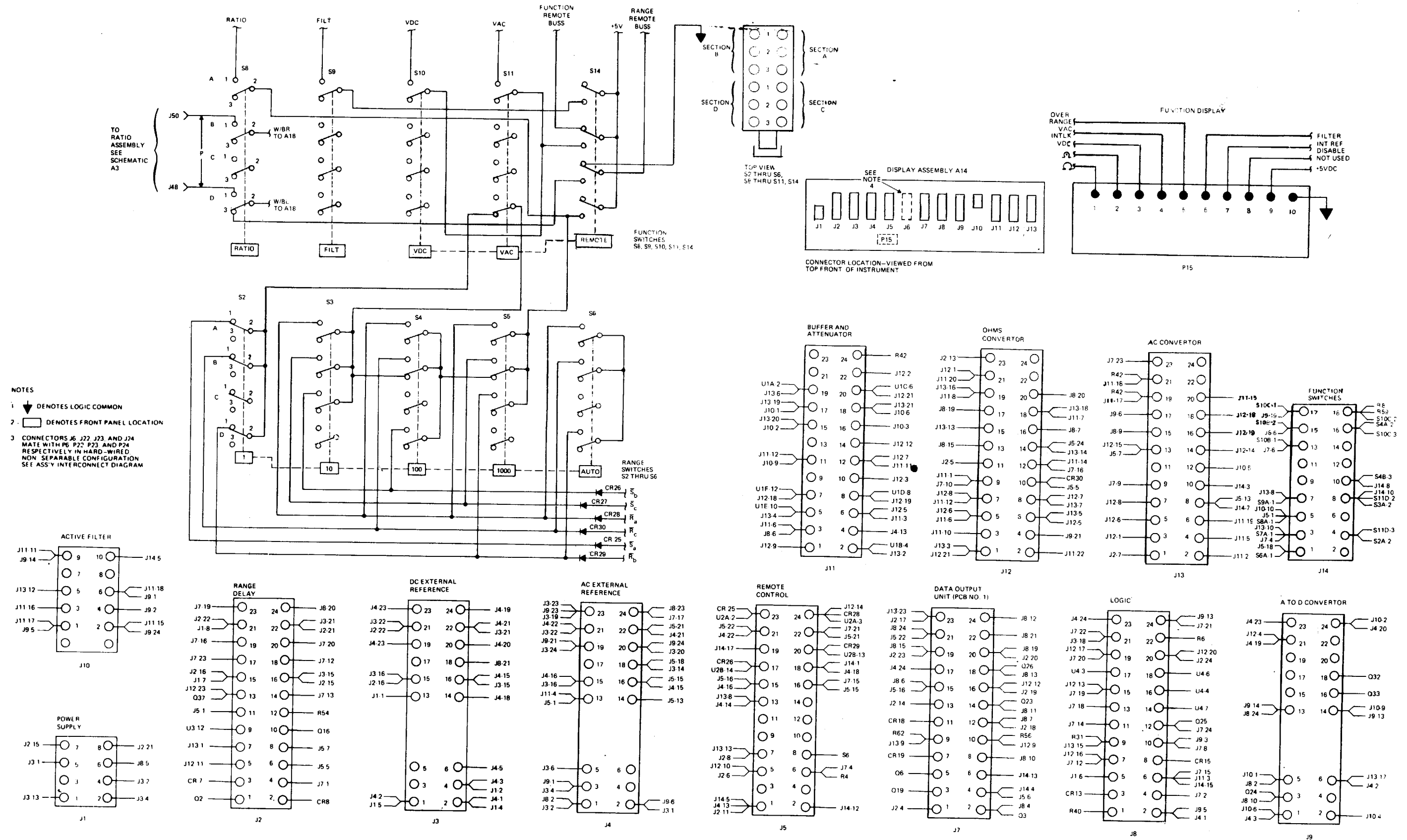
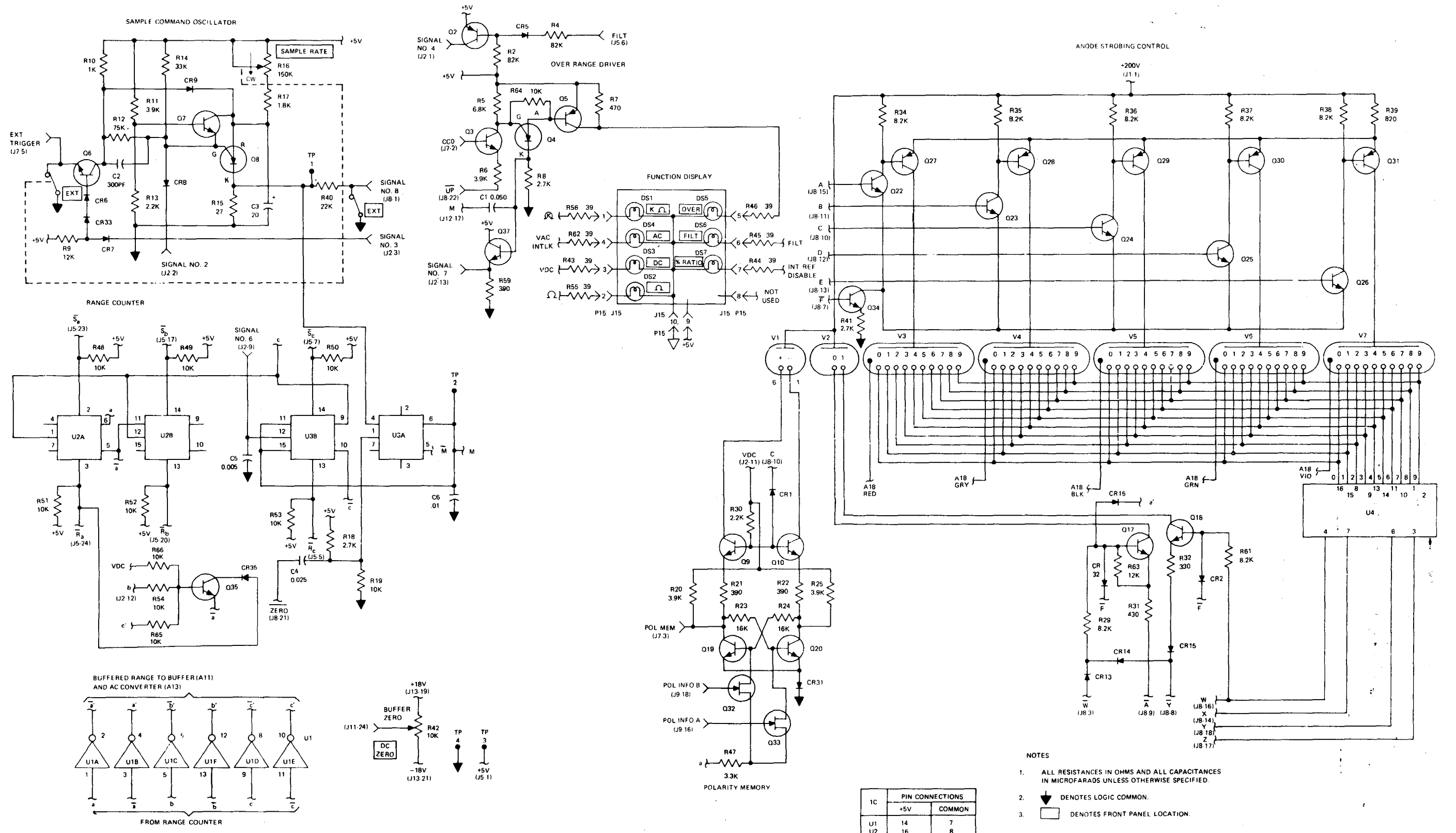
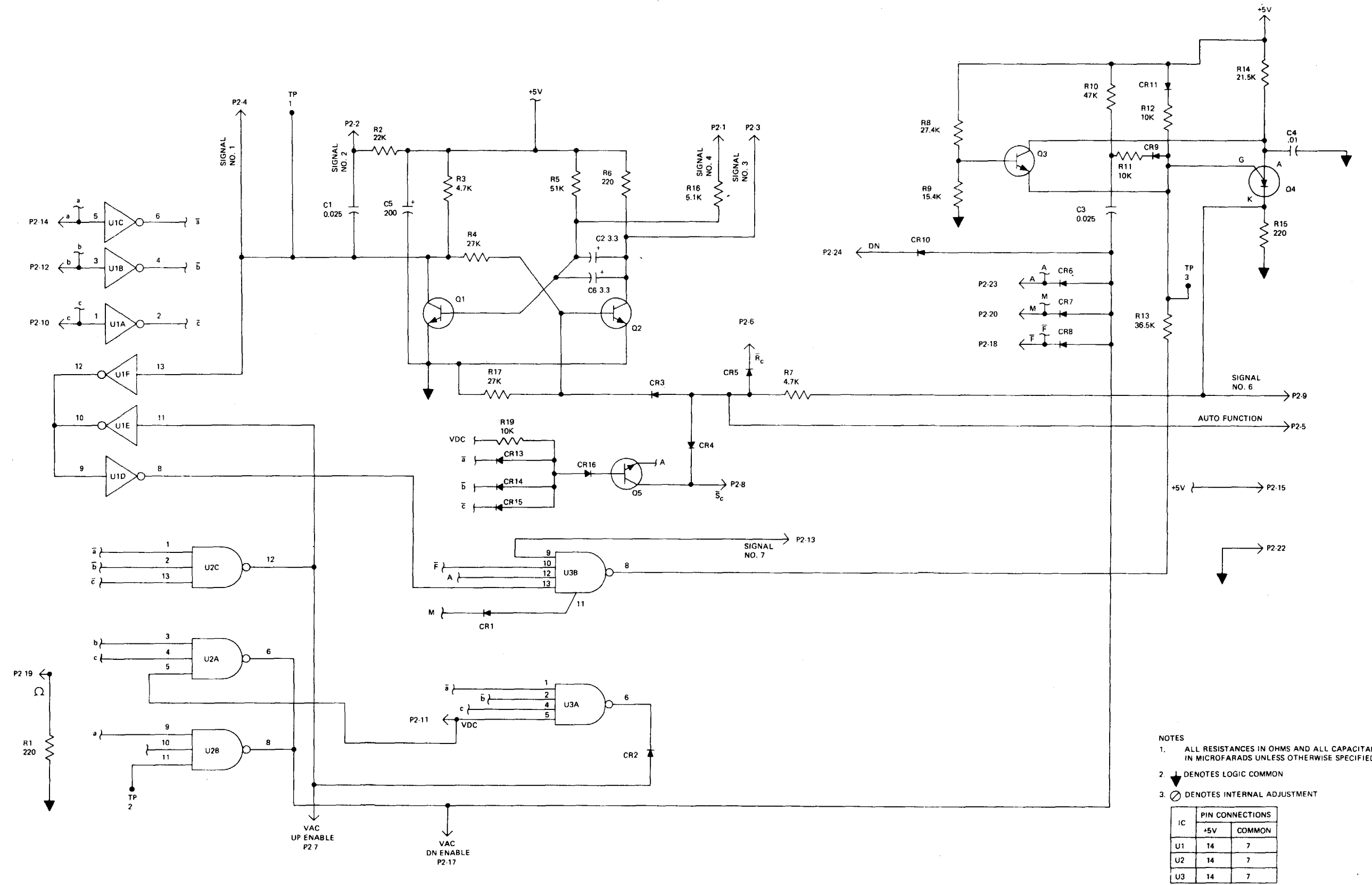

Figure FO-6 () . Display (A14) schematic diagram (sheet 1 of 2).



1C	PIN CONNECTIONS	
	+5V	COMMON
U1	14	7
U2	16	8
U3	16	8
U4	5	12

- NOTES
- ALL RESISTANCES IN OHMS AND ALL CAPACITANCES IN MICROFARADS UNLESS OTHERWISE SPECIFIED.
 - ⏏ DENOTES LOGIC COMMON.
 - DENOTES FRONT PANEL LOCATION.



- NOTES
1. ALL RESISTANCES IN OHMS AND ALL CAPACITANCES IN MICROFARADS UNLESS OTHERWISE SPECIFIED.
 2. ⚡ DENOTES LOGIC COMMON
 3. ⚙ DENOTES INTERNAL ADJUSTMENT
- | IC | PIN CONNECTIONS | |
|----|-----------------|--------|
| | +5V | COMMON |
| U1 | 14 | 7 |
| U2 | 14 | 7 |
| U3 | 14 | 7 |

Figure FO-7. Range delay (A2) schematic diagram.

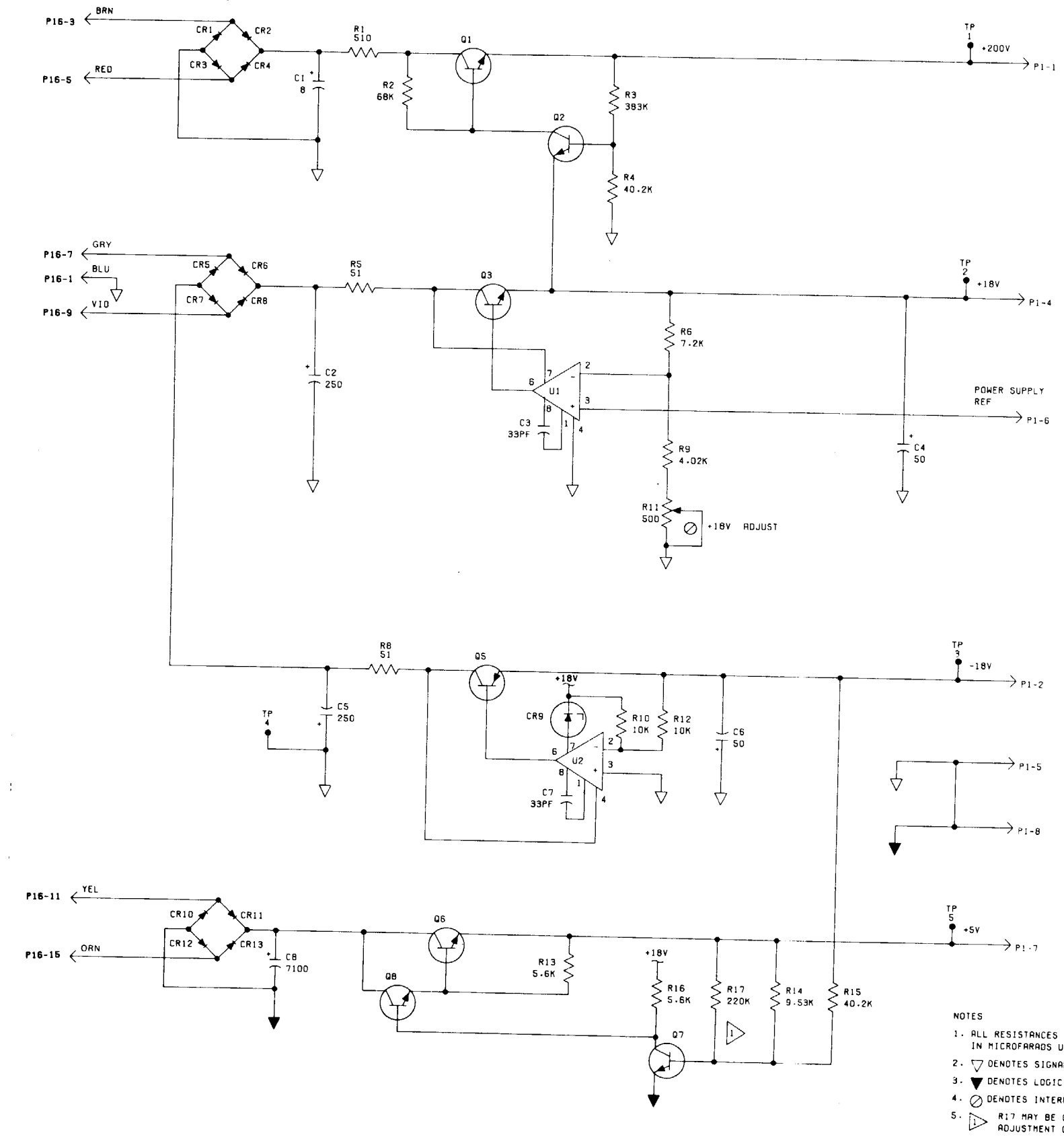

- NOTES
1. ALL RESISTANCES IN OHMS AND ALL CAPACITANCES IN MICROFARADS UNLESS OTHERWISE SPECIFIED.
 2. ▽ DENOTES SIGNAL COMMON.
 3. ▼ DENOTES LOGIC COMMON.
 4. ⊗ DENOTES INTERNAL ADJUSTMENT.
 5. △ R17 MAY BE OMITTED DURING ADJUSTMENT OF +5V SUPPLY.

Figure FO-8. Power supply (A1) schematic diagram.

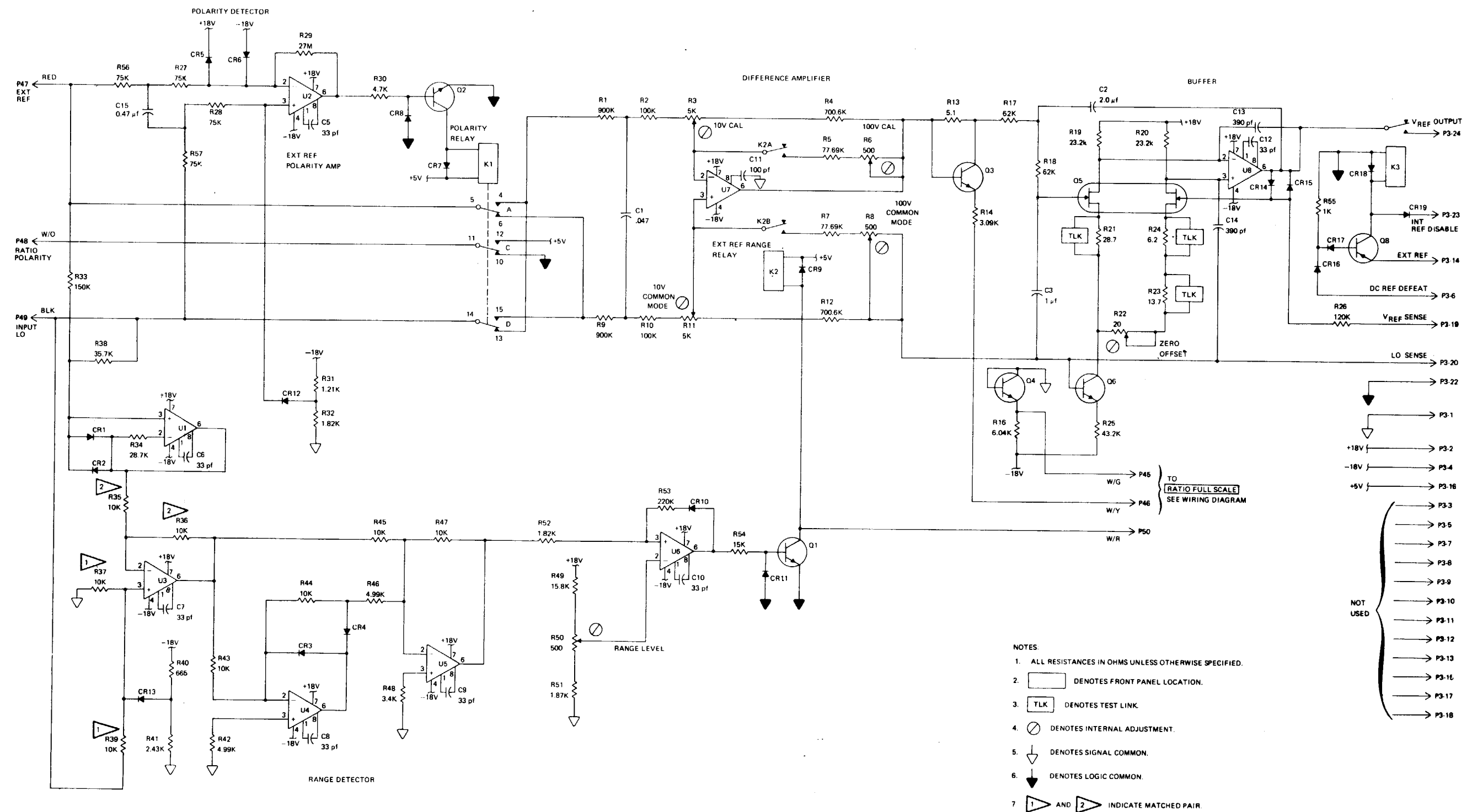
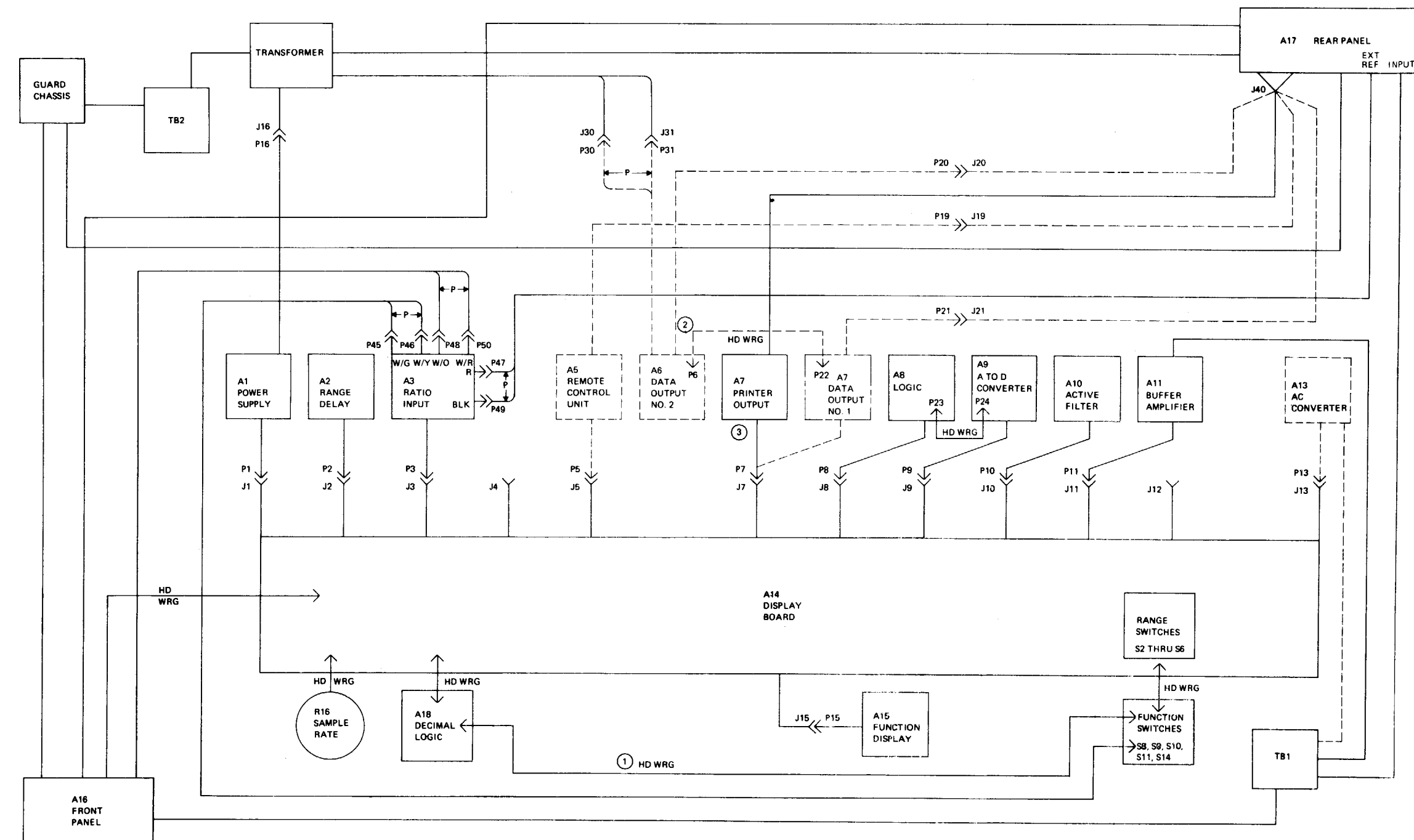

Figure FO-9. Ratio input (A3) schematic diagram.



- NOTES:
- ① HD WRG HARD WIRING NOT TO BE DISCONNECTED.
 - ② - - - CONNECTIONS NECESSARY FOR OPTIONS.
 - ③ PRINTER OUTPUT MUST BE REMOVED WHEN DATA OUTPUT OPTION IS TO BE INSTALLED.

Figure FO-10. Interconnect diagram.

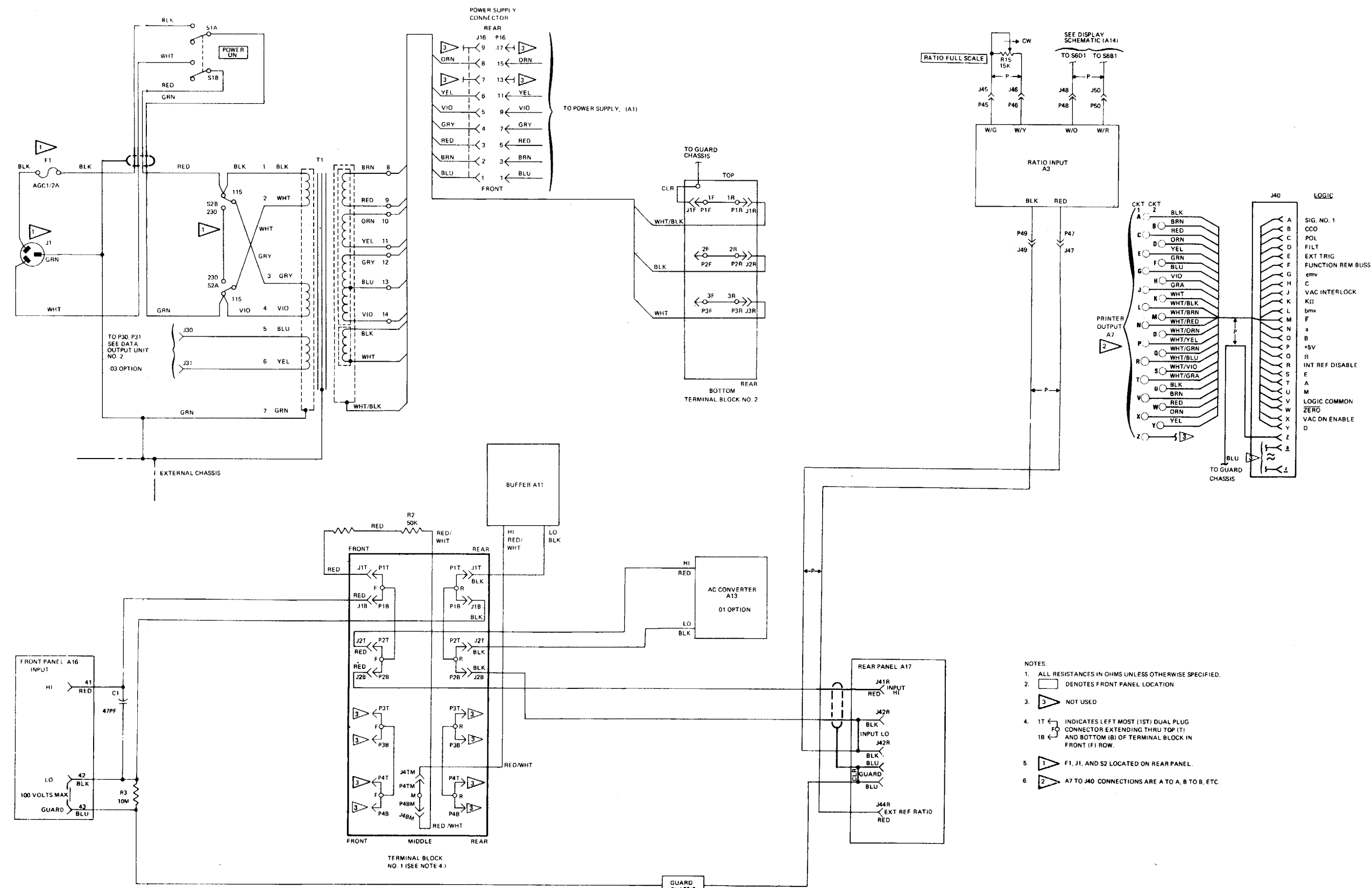
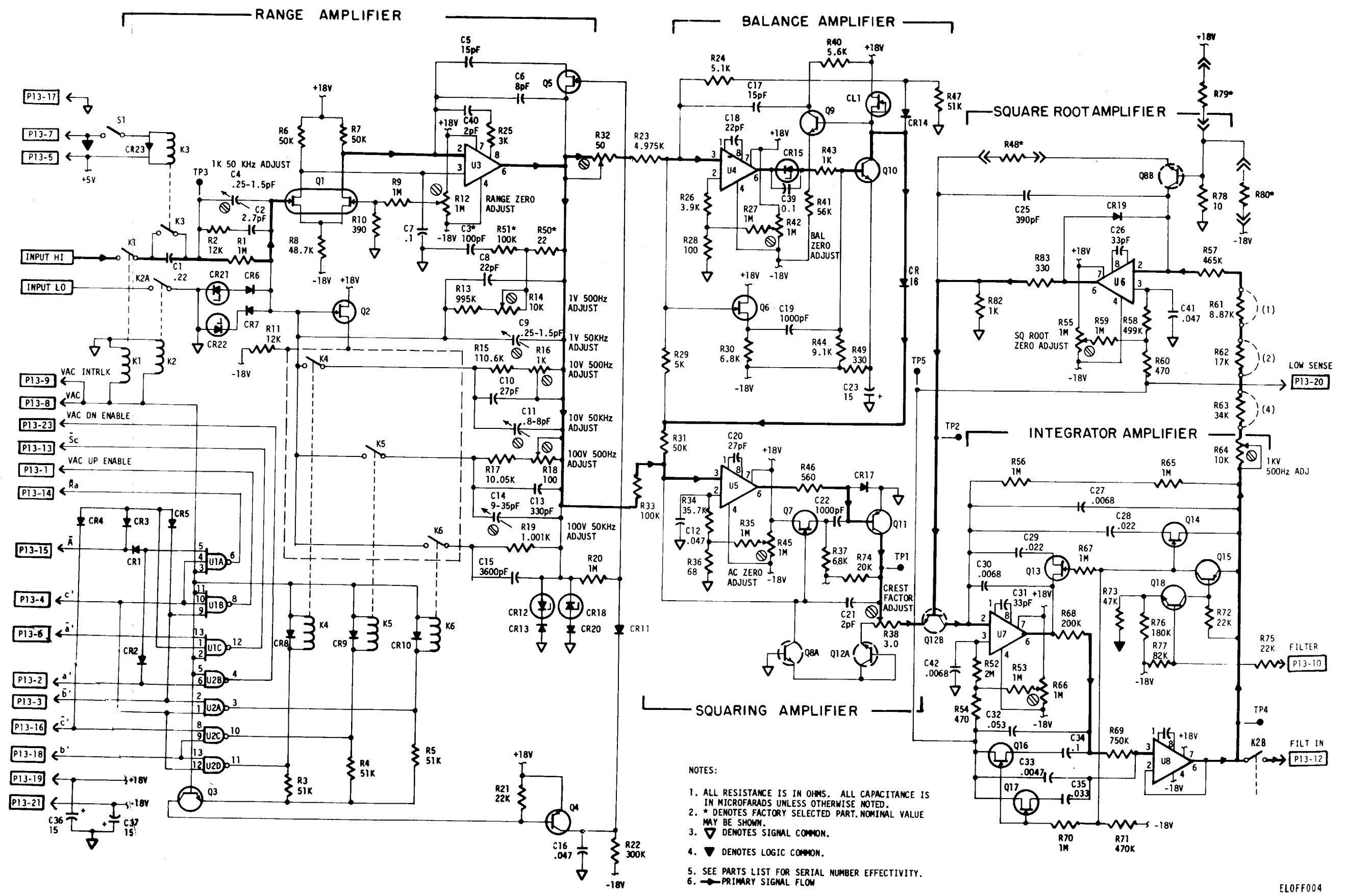

Figure FO-11. Wiring diagram.



- NOTES:
1. ALL RESISTANCE IS IN OHMS. ALL CAPACITANCE IS IN MICROFARADS UNLESS OTHERWISE NOTED.
 2. * DENOTES FACTORY SELECTED PART, NOMINAL VALUE MAY BE SHOWN.
 3. ▽ DENOTES SIGNAL COMMON.
 4. ▼ DENOTES LOGIC COMMON.
 5. SEE PARTS LIST FOR SERIAL NUMBER EFFECTIVITY.
 6. → PRIMARY SIGNAL FLOW

Figure FO-12. Ac converter, schematic diagram.



a

b



c

d



